

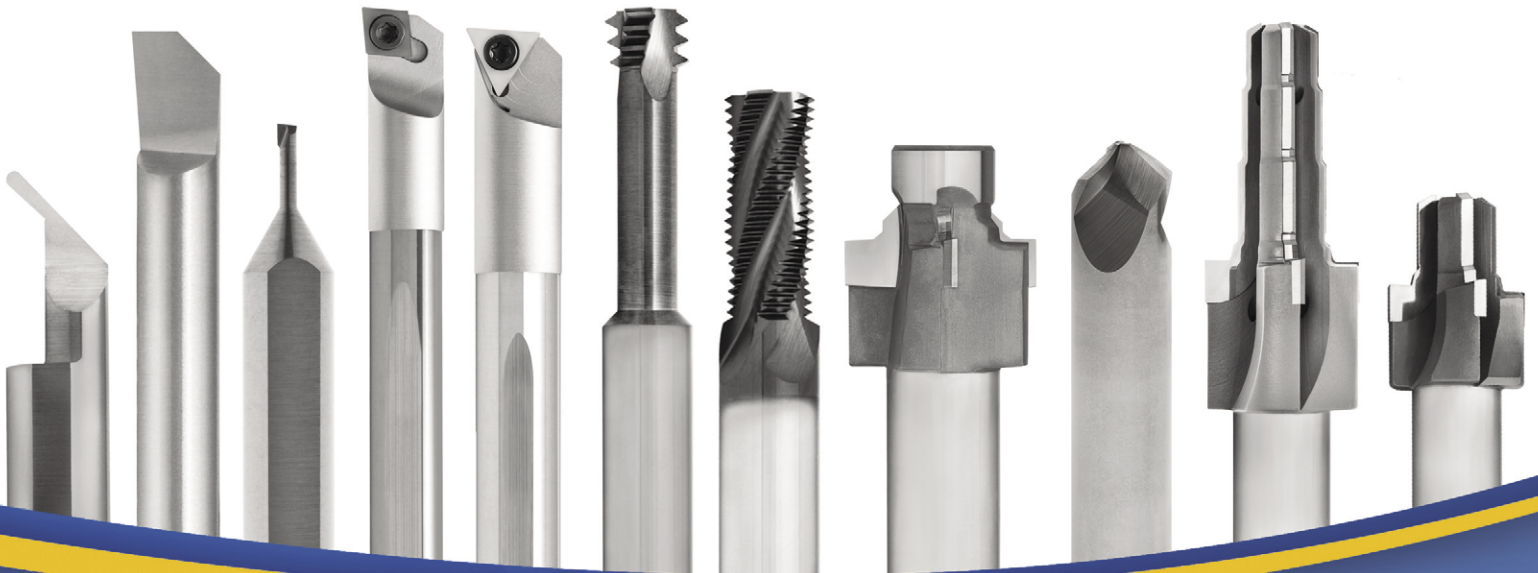

SCIENTIFIC CUTTING TOOLS



CLICK TO LEARN HOW TO USE THE INTERACTIVE

CATALOG CLICK TO REQUEST A PRINTED COPY

CLICK TO GO TO TABLE OF CONTENTS

CLICK TO VIEW BOOKMARK NAVIGATION PANEL

CLICK TO SEARCH THIS CATALOG

GO TO NEW SPOTTING DRILLS PAGE

GO TO NEW DRILL MILLS PAGE

GO TO ISO 1179 PORT TOOL

NEW! AS5202 NEW! SAEJ1926

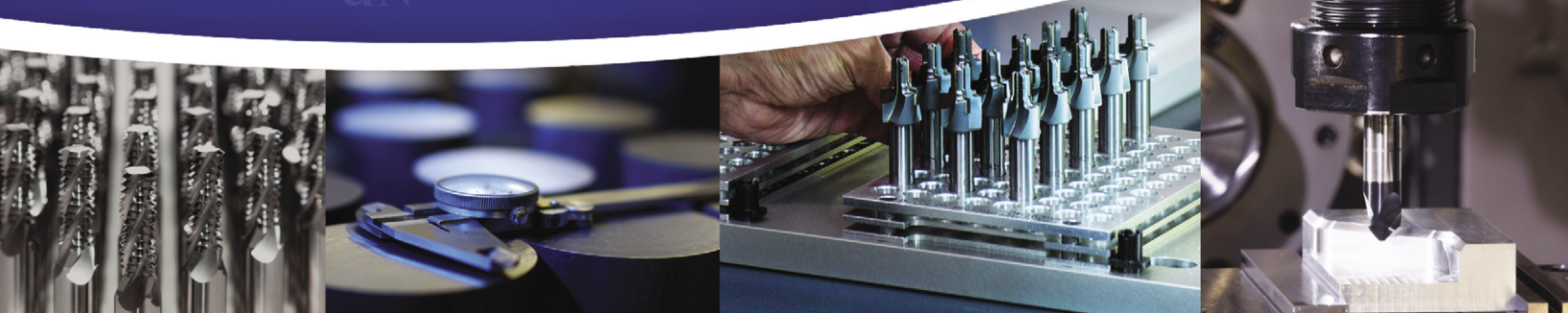



Premium Carbide Cutting Tools that Deliver Value

Scientific Cutting Tools, Inc. was **established over 55 years ago** as an innovative cutting tool manufacturer. SCT entered the cutting tool manufacturing field with innovative cutting tool designs, an inspired ambition to succeed, and **one driving goal—to deliver unprecedented value to our customers.**

Over the years, SCT has developed new tool lines and refined existing product groups. Through aggressive research and development, SCT has the capability of developing specialized tools for specific customer projects, as well as the ability to modify existing stock tools to meet individual customer needs. SCT has an excellent reputation as a manufacturer of an **extensive line of cutting tools including thread mills, port tools, cavity tools, indexable and solid carbide boring bars, threading tools, grooving tools, and more.** We stock coated (ALTiN+) and uncoated versions of our products and all carbide used in our processes must pass stringent quality tests.

Our commitment to quality control, unparalleled craftsmanship, and customer satisfaction continue to set us above the competition. Scientific Cutting Tools will continue to position itself to be the cutting edge of tomorrow's product design while still offering competitively priced products. The goal of **delivering superior quality tools backed by 100% customer satisfaction** is SCT's guarantee.

Complimentary Technical Assistance

SCT offers complimentary technical assistance during our business hours. Call **800-383-2244** or **805-584-9495**.

Online Thread Mill Code Generator

The SCT Thread Mill Generator is easy to use with quick input fields and codes for both ID and OD threads. It is designed for Fanuc and Fanuc compatible controls. Email code, download in a text file, or output to screen. Visit **www.sct-usa.com** and click on the **resources** tab.

Stay Connected with the Monthly Newsletter

As a subscriber you'll get first access to new product information and updates including exclusive interactive PDF guides. Learn more about our product lines and which trade shows and events Scientific Cutting Tools is attending. Visit **www.sct-usa.com** or the **SCT facebook page** and look for the **newsletter sign-up**.

A New Way to Order Products

SCT is introducing **EDP numbers** to this catalog. Order products using either the original SCT order # or the EDP #. In the near future, all **SCT product label barcodes will be based on the EDP #.**



www.sct-usa.com

sales@sct-usa.com



Subscribe to our channel



Scientific Cutting Tools, Inc.



[SCTcuttingtools](https://twitter.com/SCTcuttingtools)







[Scientific Cutting Tools](https://www.instagram.com/ScientificCuttingTools)



[Click here to Search](#)



Table of Contents

	THREAD MILLS.....5-32
	<i>UN.....7-18</i>
	<i>NPT.....19-21</i>
	<i>BRITISH.....22</i>
	<i>METRIC.....23-28</i>
	<i>ACME.....29-30</i>
	<i>TECHNICAL INFORMATION.....31-32</i>
	SINGLE POINT TOOLS.....33-72
	<i>HOLDERS.....35-37</i>
	<i>BORING BARS.....38-54</i>
	<i>GROOVING TOOLS.....55-61</i>
	<i>THREADING TOOLS.....62-66</i>
	<i>TECHNICAL INFORMATION.....67-72</i>
	INDEXABLE TOOLS.....73-88
	<i>BORING BARS.....74-85</i>
	<i>ACCESSORIES.....84</i>
	<i>STEP BARS.....84-85</i>
	<i>TECHNICAL INFORMATION.....86-88</i>
	PORT AND CAVITY TOOLS.....89-118
	<i>PORT TOOLS.....91-107</i>
	<i>CAVITY TOOLS.....109-118</i>
	<i>TECHNICAL INFORMATION.....108</i>
	SPECIALTY END MILLS.....119-125
	<i>HELICAL CHAMFER MILLS.....121</i>
	<i>CORNER ROUNDERS.....122</i>
	<i>ENGRAVING TOOLS.....123</i>
	<i>SPOTTING DRILLS.....NEW!</i>
	<i>DRILL MILLS.....NEW! TECH INFO.....124-125</i>

SCT is introducing EDP numbers to this catalog. Order products using either the original SCT order # or the EDP #. In the near future, all SCT product label barcodes will be based on the EDP #.

A DIGITAL COPY IS AVAILABLE ONLINE TO VIEW AND/OR DOWNLOAD AT WWW.SCT-USA.COM



NEW PRODUCT AND SIZES OVERVIEW

A New Way to Order Products

SCT is introducing **EDP numbers** to this catalog. Order products using either the original SCT order # or the EDP #. In the near future, all **SCT product label barcodes** will be based on the EDP #.

New Product:
The CRT
Holder



Coolant Ring Technology (CRT) Holder (Page 35)

- Surrounds the tool in a ring of coolant
- Use with qualified tools as a quick-change system
- Made with heat-treated steel

New Product:
Spotting
Drills



Spotting Drills

- Available in 82°, 90°, 100°, 120° & 142° included angle
- Point angle is held to $\pm 1^\circ$ tolerance
- Designed with a 4-facet point and constant web

New Product:
Eaton Vickers
Cavity Tool



Eaton Vickers Cavity Tool (p.117-118)

- Available in 2, 3, and 4 way cavities
- Rougher or Finisher style
- Carbide tipped finishing tools

New Product:
Helical
Chamfer Mill



Helical Chamfer Mill (p.121)

- 3 or 5 flute design for most effective application
- Tool tip diameter held to ± 0.002 for fast set-ups
- Positive high shear design for reduced cutting forces

New Product:
ISO6149
Large Spot Face

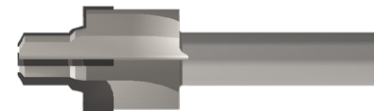

ISO6149 with Large Spot Face (p.100)

- Metric port without identification notch
- Features large spot face
- Carbide tipped port tool

New Product:
Single Point Thread Mill
External UNJ



External UNJ Single Point Thread Mill (SPTM EXJ) (p.9)

- Conforms to aerospace standard AS8879
- Available with AlTiN+ coating
- For external UNJ threads

New Product:
Sun Hydraulic
Rougher



Sun Hydraulic Rougher Cavity Tool (p.115)

- Polished flute face
- Carbide tipped
- Tool body is heat-treated steel

New Size:
Single Point Thread Mill
Extra Long



Single Point Thread Mill (SPTM) Extra Long (p.7-8)

- Cuts UNC, UNF, UNEF, & UNS threads
- Made with heat-treated steel
- Extra long shank

New Product:
Qualified
Boring Bars



Qualified Boring Bars (p.40-41)

- Overall length qualified to ± 0.001
- Minimum bore diameter qualified to ± 0.0005
- Precision ground flat for guaranteed tool orientation



THREAD MILLS



Helical Flute
Acme/Stub Acme
Single Profile (SPTM)
Long Reach (TMLR)

NPTF/ NPT
Staggered Tooth
Coolant Through
Metric

THREAD MILLS PRODUCT OVERVIEW

Thread mills cut a thread using helical interpolation. Helical interpolation involves moving three axes simultaneously. The X and Y axes move in a circular motion while the Z axis moves in a linear motion. This allows the same thread mill to cut both right and left-hand threads and to produce a variety of thread sizes of the same pitch. All thread mills are made from premium submicron carbide and are stocked with and without an ALTiN+ coating. They are ground on state-of-the-art CNC tool-and-cutter grinders and have been engineered for high performance. Programming assistance is available. Technical information available on pages 31-32.

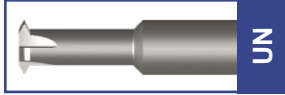

SPTM (p.7-8)
Single profile thread mills cut internal and external threads in a range of thread sizes with minimum side cutting pressure.

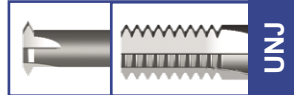

EXTERNAL (p. 9)
The straight flute EXJ and SPTM EXJ have the root radius that is required for the external "UNJ" thread.

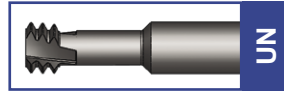

TLMR (p.10-11)
Long reach thread mills have three teeth and a helical flute that excel in internal deep threads and hard-to-cut materials.

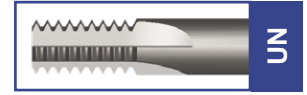

STRAIGHT FLUTE (p.12-15)
Straight flute thread mills come in a large variety of sizes and are crest cutting for internal threads only.

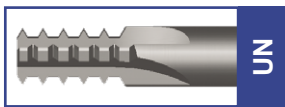

STAGGERED TOOTH (p.16)
Staggered tooth thread mills cut internal and external threads. Every other tooth is removed in a staggered pattern for reduced side cutting pressure.

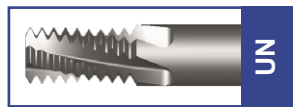

15° HELICAL FLUTE (p.17)
15° helical flute thread mills are non-crest cutting and for internal threads only. The helical flutes distribute the side cutting pressure.



30° HELICAL FLUTE (p.18)
The 30° helical flute thread mills cut internal and external threads. The helical flutes distribute the side cutting pressure.

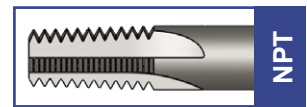

NPT / NPTF (p.19-21)
NPT thread mills come in straight, helical and staggered tooth design. They cut both internal and external threads. NPTF are for dryseal applications.

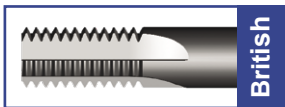

BSPP / BSPT (p.22)
These straight flute thread mills have a 55° thread profile and cut the British Standard Pipe Parallel (BSPP) and the British Standard Pipe Taper (BSPT).

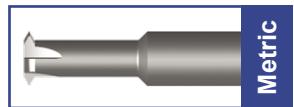

SPTM METRIC (p.23-24)
Single profile thread mills cut internal and external threads in a range of thread sizes with minimum side cutting pressure.

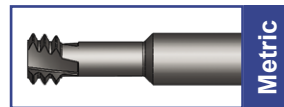

TLMR METRIC (p.25)
Long reach thread mills have three teeth and a helical flute that excel in internal deep threads and hard to cut materials.

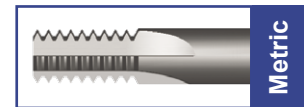

STRAIGHT FLUTE (p.26-27)
Straight flute thread mills come in a large variety of sizes and are crest cutting for internal threads only.

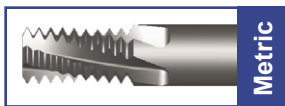

15° HELICAL FLUTE (p.28)
15° helical flute thread mills are non-crest cutting for internal threads only. The helical flute distributes the side cutting pressure.



30° HELICAL FLUTE (p.28)
30° helical flute thread mills cut internal and external threads. The helical flute distributes side cutting pressure.

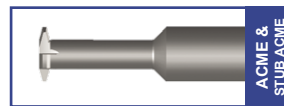

ACME / STUB ACME (p.29-30)
Acme thread mills come in both acme and stub acme configurations. Different tools are available to cut the internal and external threads.

**FREE THREAD MILL CODE GENERATOR FOR SCT THREAD MILLS
AVAILABLE NOW AT WWW.SCT-USA.COM**



- EASY TO USE WITH SIMPLE INPUT FIELDS
- QUICKLY GENERATES CODE TO SAVE TIME
- FANUC AND FANUC COMPATIBLE CONTROLS
- GENERATES CODES FOR ID AND OD THREADS

THREAD MILL LOCATOR CHART ONLINE

THREAD MILL TECH INFORMATION PAGES 31-32

UN THREAD MILLS

SINGLE PROFILE (SPTM) - SOLID CARBIDE

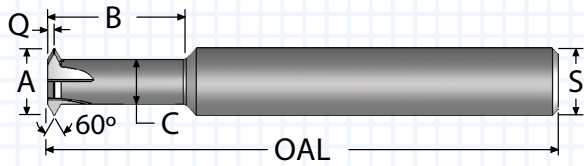

Fine and coarse threads ranging from #00 to 1¼ + can be milled using the 21 varieties of these single profile thread mills.

MIN INTERNAL THREAD*	"A" TOOL DIA.	"B" LENGTH OF CUT	"C" NECK DIA.	"Q" LENGTH	"S" SHANK DIA.	OAL	FLUTES	INTERNAL LIMITS TPI	EXTERNAL LIMITS TPI	ORDER #		EDP #	
										UNCOATED	AITiN+	UNCOATED	AITiN+
#00	0.032	0.060	0.018	0.005	0.1250	1.50	2	90 to 120	----	SPTM032	SPTM032A	120001	120067
#00	0.032	0.100	0.018	0.005	0.1250	1.50	2	90 to 120	----	SPTM032L	SPTM032LA	120004	120070
#0	0.040	0.090	0.022	0.006	0.1250	1.50	2	80 to 100	90 to 100	SPTM040	SPTM040A	120007	120073
#0	0.040	0.109	0.022	0.006	0.1250	1.50	2	80 to 100	90 to 100	SPTM040ML	SPTM040MLA	120013	120079
#0	0.040	0.125	0.022	0.006	0.1250	1.50	2	80 to 100	90 to 100	SPTM040L	SPTM040LA	120010	120076
#1	0.050	0.100	0.028	0.007	0.1250	1.50	3	64 to 80	72 to 80	SPTM050	SPTM050A	120016	120082
#1	0.050	0.125	0.028	0.007	0.1250	1.50	3	64 to 80	72 to 80	SPTM050ML	SPTM050MLA	120022	120088
#1	0.050	0.150	0.028	0.007	0.1250	1.50	3	64 to 80	72 to 80	SPTM050L	SPTM050LA	120019	120085
#1	0.050	0.210	0.028	0.007	0.1250	1.50	3	64 to 80	72 to 80	SPTM050XL	SPTM050XLA	120020	120086
#2	0.059	0.125	0.034	0.008	0.1250	1.50	3	56 to 80	72 to 80	SPTM059	SPTM059A	120025	120091
#2	0.059	0.165	0.034	0.008	0.1250	1.50	3	56 to 80	72 to 80	SPTM059ML	SPTM059MLA	120031	120097
#2	0.059	0.200	0.034	0.008	0.1250	1.50	3	56 to 80	72 to 80	SPTM059L	SPTM059LA	120028	120094
#2	0.059	0.250	0.034	0.008	0.1250	1.50	3	56 to 80	72 to 80	SPTM059XL	SPTM059XLA	120029	120095
#2	0.060	0.125	0.034	0.009	0.1875	2.00	3	56 to 80	72 to 80	SPTM060	SPTM060A	120100	120214
#2	0.060	0.165	0.034	0.009	0.1875	2.00	3	56 to 80	72 to 80	SPTM060ML	SPTM060MLA	120106	120220
#2	0.060	0.200	0.034	0.009	0.1875	2.00	3	56 to 80	72 to 80	SPTM060L	SPTM060LA	120103	120217
#3	0.072	0.150	0.040	0.010	0.1875	2.00	3	48 to 80	56 to 80	SPTM072	SPTM072A	120109	120223
#3	0.072	0.250	0.040	0.010	0.1875	2.00	3	48 to 80	56 to 80	SPTM072L	SPTM072LA	120112	120226
#3	0.072	0.300	0.040	0.010	0.1875	2.00	3	48 to 80	56 to 80	SPTM072XL	SPTM072XLA	120113	120227
#4	0.080	0.190	0.045	0.011	0.1875	2.00	3	40 to 80	48 to 80	SPTM080	SPTM080A	120115	120229
#4	0.080	0.250	0.045	0.011	0.1875	2.00	3	40 to 80	48 to 80	SPTM080ML	SPTM080MLA	120121	120235
#4	0.080	0.300	0.045	0.011	0.1875	2.00	3	40 to 80	48 to 80	SPTM080L	SPTM080LA	120118	120232
#4	0.080	0.375	0.045	0.011	0.1875	2.00	3	40 to 80	48 to 80	SPTM080XL	SPTM080XLA	120119	120233
#5	0.090	0.200	0.048	0.013	0.1875	2.00	3	36 to 56	40 to 56	SPTM090	SPTM090A	120422	120425
#5	0.090	0.300	0.048	0.013	0.1875	2.00	3	36 to 56	40 to 56	SPTM090L	SPTM090LA	120431	120434
#5	0.090	0.400	0.048	0.013	0.1875	2.00	3	36 to 56	40 to 56	SPTM090XL	SPTM090XLA	120440	120443
#6	0.098	0.250	0.050	0.015	0.1875	2.00	3	32 to 56	36 to 56	SPTM098	SPTM098A	120124	120238
#6	0.098	0.330	0.050	0.015	0.1875	2.00	3	32 to 56	36 to 56	SPTM098ML	SPTM098MLA	120130	120244
#6	0.098	0.400	0.050	0.015	0.1875	2.00	3	32 to 56	36 to 56	SPTM098L	SPTM098LA	120127	120241
#8	0.120	0.300	0.070	0.016	0.1875	2.00	3	32 to 56	32 to 56	SPTM120	SPTM120A	120133	120247
#8	0.120	0.400	0.070	0.016	0.1875	2.00	3	32 to 56	32 to 56	SPTM120ML	SPTM120MLA	120139	120253
#8	0.120	0.500	0.070	0.016	0.1875	2.00	3	32 to 56	32 to 56	SPTM120L	SPTM120LA	120136	120250
#10	0.138	0.400	0.075	0.020	0.1875	2.00	3	24 to 48	28 to 48	SPTM138	SPTM138A	120142	120256
#10	0.138	0.500	0.075	0.020	0.1875	2.00	3	24 to 48	28 to 48	SPTM138ML	SPTM138MLA	120148	120262
#10	0.138	0.600	0.075	0.020	0.1875	2.00	3	24 to 48	28 to 48	SPTM138L	SPTM138LA	120145	120259
#12	0.160	0.400	0.080	0.025	0.1875	2.00	3	20 to 48	24 to 48	SPTM160	SPTM160A	120151	120265
#12	0.160	0.650	0.080	0.025	0.1875	2.00	3	20 to 48	24 to 48	SPTM160L	SPTM160LA	120154	120268

*Single profile thread mills can cut any larger diameter internal thread within the TPI limits

[Go to Thread Mill Overview](#)

UN THREAD MILLS

SINGLE PROFILE (SPTM) - SOLID CARBIDE

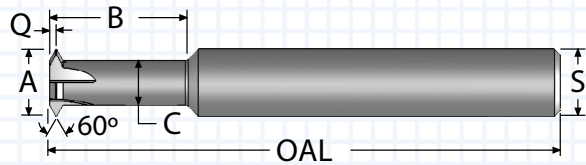

- Solid carbide provides maximum tool rigidity
- Long reach tools are available from stock
- Cuts UNC, UNF, UNEF, and UNS threads
- Cuts UNJ threads (internal only)

MIN INTERNAL THREAD*	"A" TOOL DIA.	"B" LENGTH OF CUT	"C" NECK DIA.	"Q" LENGTH	"S" SHANK DIA.	OAL	FLUTES	INTERNAL LIMITS TPI	EXTERNAL LIMITS TPI	ORDER #		EDP #	
										UNCOATED	AITiN+	UNCOATED	AITiN+
										INTERNAL OR EXTERNAL THREADS			
1/4	0.182	0.400	0.104	0.025	0.2500	2.50	4	18 to 48	24 to 48	SPTM182	SPTM182A	120271	120301
1/4	0.182	0.530	0.104	0.025	0.2500	2.50	4	18 to 48	24 to 48	SPTM182ML	SPTM182MLA	120277	120307
1/4	0.182	0.650	0.104	0.025	0.2500	2.50	4	18 to 48	24 to 48	SPTM182L	SPTM182LA	120274	120304
1/4	0.182	0.800	0.104	0.025	0.2500	2.50	4	18 to 48	24 to 48	SPTM182XL	SPTM182XLA	120275	120305
5/16	0.240	0.500	0.153	0.028	0.2500	2.50	4	16 to 48	20 to 48	SPTM240	SPTM240A	120280	120310
5/16	0.240	0.800	0.153	0.028	0.2500	2.50	4	16 to 48	20 to 48	SPTM240L	SPTM240LA	120283	120313
5/16	0.240	1.100	0.153	0.028	0.2500	2.50	4	16 to 48	20 to 48	SPTM240XL	SPTM240XLA	120284	120314
3/8	0.290	0.600	0.192	0.031	0.3750	3.00	4	14 to 48	18 to 48	SPTM290	SPTM290A	120316	120340
3/8	0.290	1.000	0.192	0.031	0.3750	3.00	4	14 to 48	18 to 48	SPTM290L	SPTM290LA	120319	120343
3/8	0.290	1.400	0.192	0.031	0.3750	3.00	4	14 to 48	18 to 48	SPTM290XL	SPTM290XLA	120320	120344
7/16	0.332	0.700	0.220	0.035	0.3750	3.00	4	14 to 48	16 to 48	SPTM332	SPTM332A	120450	120453
7/16	0.332	1.100	0.220	0.035	0.3750	3.00	4	14 to 48	16 to 48	SPTM332L	SPTM332LA	120459	120462
7/16	0.332	1.500	0.220	0.035	0.3750	3.00	4	14 to 48	16 to 48	SPTM332XL	SPTM332XLA	120468	120471
1/2	0.372	0.850	0.240	0.041	0.3750	3.00	4	12 to 48	12 to 48	SPTM372	SPTM372A	120322	120346
1/2	0.372	1.250	0.240	0.041	0.3750	3.00	4	12 to 48	12 to 48	SPTM372L	SPTM372LA	120325	120349
1/2	0.372	1.750	0.240	0.041	0.3750	4.00	4	12 to 48	12 to 48	SPTM372XL	SPTM372XLA	120326	120350
5/8	0.488	0.850	0.340	0.046	0.5000	3.50	5	11 to 32	11 to 32	SPTM488	SPTM488A	120352	120364
5/8	0.488	1.350	0.340	0.046	0.5000	3.50	5	11 to 32	11 to 32	SPTM488L	SPTM488LA	120355	120367
5/8	0.488	2.000	0.340	0.046	0.5000	4.00	5	11 to 32	11 to 32	SPTM488XL	SPTM488XLA	120356	120368
3/4	0.595	1.250	0.430	0.051	0.6250	4.00	6	10 to 32	10 to 32	SPTM595	SPTM595A	120370	120382
3/4	0.595	2.000	0.430	0.051	0.6250	4.00	6	10 to 32	10 to 32	SPTM595L	SPTM595LA	120373	120385
3/4	0.595	2.750	0.430	0.051	0.6250	5.00	6	10 to 32	10 to 32	SPTM595XL	SPTM595XLA	120374	120386
7/8	0.695	1.500	0.490	0.063	0.7500	5.00	6	8 to 24	8 to 24	SPTM695	SPTM695A	120388	120412
7/8	0.695	2.500	0.490	0.063	0.7500	5.00	6	8 to 24	8 to 24	SPTM695L	SPTM695LA	120391	120415
7/8	0.695	3.250	0.490	0.063	0.7500	6.00	6	8 to 24	8 to 24	SPTM695XL	SPTM695XLA	120392	120416
1 1/4	0.745	1.500	0.400	0.107	0.7500	5.00	6	4 to 8	6 to 10	SPTM745	SPTM745A	120394	120418
1 1/4	0.745	2.500	0.400	0.107	0.7500	5.00	6	4 to 8	6 to 10	SPTM745L	SPTM745LA	120397	120421
1 1/4	0.745	3.250	0.400	0.107	0.7500	6.00	6	4 to 8	6 to 10	SPTM745XL	SPTM745XLA	120398	120423

*Single profile thread mills can cut any larger diameter internal thread within the TPI limits

[Go to Thread Mill Overview](#)

UN THREAD MILLS

SINGLE PROFILE (SPTM) - EXTERNAL UNJ - SOLID CARBIDE

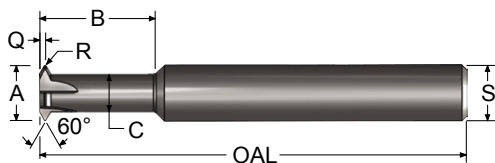

- Non-crest cutting allows maximum flexibility for plated and non-standard threads
- Minimal side cutting pressure
- Conforms to aerospace standard AS8879

EXT. THREAD / PITCH	"A" TOOL DIA.	"B" LENGTH OF CUT	"C" NECK DIA.	"R" ROOT RADIUS	"Q" LENGTH	"S" SHANK DIA.	OAL	FLUTES	ORDER #		EDP #	
									UNCOATED	AITiN+	UNCOATED	AITiN+
									EXTERNAL ONLY			
UNJ-32	0.372	1.000	0.240	0.0051	0.043	0.375	3.00	4	SPTM372-32EXJ	SPTM372-32EXJ-A	120916	120934
UNJ-28	0.372	1.000	0.240	0.0059	0.043	0.375	3.00	4	SPTM372-28EXJ	SPTM372-28EXJ-A	120913	120931
UNJ-24	0.372	1.000	0.240	0.0069	0.044	0.375	3.00	4	SPTM372-24EXJ	SPTM372-24EXJ-A	120910	120928
UNJ-20	0.372	1.000	0.240	0.0082	0.044	0.375	3.00	4	SPTM372-20EXJ	SPTM372-20EXJ-A	120907	120925
UNJ-18	0.372	1.000	0.240	0.0091	0.045	0.375	3.00	4	SPTM372-18EXJ	SPTM372-18EXJ-A	120904	120922
UNJ-16	0.372	1.000	0.240	0.0103	0.046	0.375	3.00	4	SPTM372-16EXJ	SPTM372-16EXJ-A	120901	120919
UNJ-12	0.488	1.400	0.340	0.0137	0.052	0.500	3.50	5	SPTM488-12EXJ	SPTM488-12EXJ-A	120937	120940

THREAD MILLS - EXJ - SOLID CARBIDE

(EXTERNAL UNJ THREAD)

FULL PROFILE

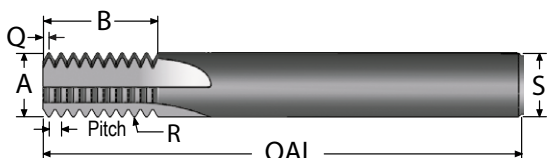

- ALTiN+ coating extends tool life
- Precision ground for maximum concentricity
- Made with premium submicron carbide

EXT. THREAD / PITCH	"A" TOOL DIA.	"B" LENGTH OF CUT	"R" ROOT RADIUS	"Q" LENGTH	"S" SHANK DIA.	OAL	FLUTES	ORDER #		EDP #	
								UNCOATED	AITiN+	UNCOATED	AITiN+
								EXTERNAL THREADS ONLY			
UNJ-32	0.245	0.668	0.0051	0.016	0.250	2.50	4	TM245-32EXJ	TM245-32EXJ-A	104007	104025
UNJ-28	0.245	0.657	0.0059	0.018	0.250	2.50	4	TM245-28EXJ	TM245-28EXJ-A	104004	104022
UNJ-24	0.245	0.683	0.0069	0.020	0.250	2.50	4	TM245-24EXJ	TM245-24EXJ-A	104001	104019
UNJ-20	0.370	0.773	0.0082	0.024	0.375	3.50	5	TM370-20EXJ	TM370-20EXJ-A	104034	104052
UNJ-18	0.370	0.800	0.0091	0.026	0.375	3.50	5	TM370-18EXJ	TM370-18EXJ-A	104031	104049
UNJ-16	0.370	0.774	0.0103	0.029	0.375	3.50	5	TM370-16EXJ	TM370-16EXJ-A	104028	104046
UNJ-14	0.495	1.027	0.0118	0.033	0.500	3.50	6	TM495-14EXJ	TM495-14EXJ-A	104061	104085
UNJ-12	0.495	1.031	0.0137	0.038	0.500	3.50	6	TM495-12EXJ	TM495-12EXJ-A	104058	104082
UNJ-10	0.495	1.037	0.0165	0.046	0.500	3.50	6	TM495-10EXJ	TM495-10EXJ-A	104055	104079
UNJ-8	0.495	1.046	0.0207	0.057	0.500	3.50	6	TM495-8EXJ	TM495-8EXJ-A	104064	104088

[Go to Thread Mill Overview](#)

Scientific Cutting Tools offers two external UNJ thread cutting options: the partial profile SPTM EXJ and the full profile EXJ Thread Mill. Both tools conform to aerospace standard AS8879.

UN THREAD MILLS

LONG REACH (TMLR) - SOLID CARBIDE

FULL PROFILE

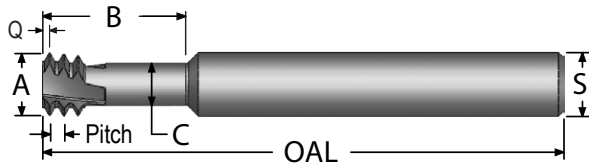

- Small thread milling is made easy with TMLR tools
- Economical cost per hole
- Minimal cutting pressure
- ALTiN+ coating for higher Surface Feet per Minute

MIN ID THREAD /PITCH*	"A" TOOL DIA.	"B" LENGTH OF CUT	"C" NECK DIA.	"Q" LENGTH	"S" SHANK DIA.	OAL	FLUTES	ORDER #		EDP #	
								UNCOATED	ALTiN+	UNCOATED	ALTiN+
								<i>INTERNAL THREADS ONLY</i>			
2-56	0.065	0.150	0.039	0.009	0.250	2.50	3	TMLR065-56	TMLR065-56A	110501	110603
2-56	0.065	0.200	0.039	0.009	0.250	2.50	3	TMLR065-56EL	TMLR065-56ELA	110504	110606
4-40	0.082	0.225	0.046	0.013	0.250	2.50	3	TMLR082-40	TMLR082-40A	110507	110609
4-40	0.082	0.300	0.046	0.013	0.250	2.50	3	TMLR082-40EL	TMLR082-40ELA	110510	110612
6-32	0.100	0.260	0.056	0.016	0.250	2.50	3	TMLR100-32	TMLR100-32A	110513	110615
6-32	0.100	0.400	0.056	0.016	0.250	2.50	3	TMLR100-32EL	TMLR100-32ELA	110516	110618
6-40	0.100	0.260	0.065	0.013	0.250	2.50	3	TMLR100-40	TMLR100-40A	110519	110621
6-40	0.100	0.400	0.065	0.013	0.250	2.50	3	TMLR100-40EL	TMLR100-40ELA	110522	110624
8-32	0.126	0.300	0.080	0.016	0.250	2.50	3	TMLR126-32	TMLR126-32A	110525	110627
8-32	0.126	0.500	0.080	0.016	0.250	2.50	3	TMLR126-32EL	TMLR126-32ELA	110528	110630
8-36	0.126	0.300	0.085	0.014	0.250	2.50	3	TMLR126-36	TMLR126-36A	110531	110633
8-36	0.126	0.500	0.085	0.014	0.250	2.50	3	TMLR126-36EL	TMLR126-36ELA	110534	110636
10-24	0.139	0.400	0.080	0.021	0.250	2.50	3	TMLR139-24	TMLR139-24A	110537	110639
10-24	0.139	0.600	0.080	0.021	0.250	2.50	3	TMLR139-24EL	TMLR139-24ELA	110540	110642
10-32	0.139	0.400	0.093	0.016	0.250	2.50	3	TMLR139-32	TMLR139-32A	110543	110645
10-32	0.139	0.600	0.093	0.016	0.250	2.50	3	TMLR139-32EL	TMLR139-32ELA	110546	110648
10-48	0.139	0.400	0.106	0.010	0.250	2.50	3	TMLR139-48	TMLR139-48A	110549	110651
10-48	0.139	0.600	0.106	0.010	0.250	2.50	3	TMLR139-48EL	TMLR139-48ELA	110552	110654
1/4-20	0.186	0.500	0.112	0.025	0.250	2.50	3	TMLR186-20	TMLR186-20A	110555	110657
1/4-20	0.186	0.700	0.112	0.025	0.250	2.50	3	TMLR186-20EL	TMLR186-20ELA	110558	110660
1/4-28	0.186	0.500	0.130	0.018	0.250	2.50	3	TMLR186-28	TMLR186-28A	110561	110663
1/4-28	0.186	0.700	0.130	0.018	0.250	2.50	3	TMLR186-28EL	TMLR186-28ELA	110564	110666
1/4-32	0.186	0.500	0.140	0.016	0.250	2.50	3	TMLR186-32	TMLR186-32A	110567	110669
1/4-32	0.186	0.700	0.140	0.016	0.250	2.50	3	TMLR186-32EL	TMLR186-32ELA	110570	110672
5/16-18	0.234	0.600	0.156	0.028	0.250	2.50	3	TMLR234-18	TMLR234-18A	110573	110675
5/16-18	0.234	0.850	0.156	0.028	0.250	2.50	3	TMLR234-18EL	TMLR234-18ELA	110576	110678
5/16-24	0.234	0.600	0.176	0.021	0.250	2.50	3	TMLR234-24	TMLR234-24A	110579	110681
5/16-24	0.234	0.850	0.176	0.021	0.250	2.50	3	TMLR234-24EL	TMLR234-24ELA	110582	110684
5/16-28	0.234	0.600	0.180	0.018	0.250	2.50	3	TMLR234-28	TMLR234-28A	110585	110687
5/16-28	0.234	0.850	0.180	0.018	0.250	2.50	3	TMLR234-28EL	TMLR234-28ELA	110588	110690
5/16-32	0.234	0.600	0.188	0.016	0.250	2.50	3	TMLR234-32	TMLR234-32A	110591	110693
5/16-32	0.234	0.850	0.188	0.016	0.250	2.50	3	TMLR234-32EL	TMLR234-32ELA	110594	110696
5/16-40	0.234	0.600	0.194	0.013	0.250	2.50	3	TMLR234-40	TMLR234-40A	110597	110699
5/16-40	0.234	0.850	0.194	0.013	0.250	2.50	3	TMLR234-40EL	TMLR234-40ELA	110600	110702

*Single profile thread mills can cut any larger size internal thread within the recommended TPI

[Go to Thread Mill Overview](#)

THREAD MILLS
UN

SINGLE POINT

INDEXABLE TOOLS

PORT - CAVITY

SPECIALTY

UN THREAD MILLS

LONG REACH (TMLR) - SOLID CARBIDE

FULL PROFILE

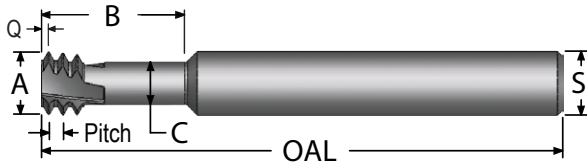

- Cuts UNC, UNF, UNEF, and UNS threads
- Cuts UNJ threads (internal only)
- Excels in difficult-to-thread materials
- ALTiN+ coating extends tool life

MIN ID THREAD /PITCH *	"A" TOOL DIA.	"B" LENGTH OF CUT	"C" NECK DIA.	"Q" LENGTH	"S" SHANK DIA.	OAL	FLUTES	ORDER #		EDP #	
								UNCOATED	AITiN	UNCOATED	ALTiN+
								<i>INTERNAL THREADS ONLY</i>			
3/8-16	0.285	0.750	0.191	0.031	0.375	3.50	3	TMLR285-16	TMLR285-16A	110705	110771
3/8-16	0.285	1.000	0.191	0.031	0.375	3.50	3	TMLR285-16EL	TMLR285-16ELA	110708	110774
3/8-24	0.285	0.750	0.222	0.021	0.375	3.50	3	TMLR285-24	TMLR285-24A	110711	110777
3/8-24	0.285	1.000	0.222	0.021	0.375	3.50	3	TMLR285-24EL	TMLR285-24ELA	110714	110780
3/8-32	0.285	0.750	0.235	0.016	0.375	3.50	3	TMLR285-32	TMLR285-32A	110717	110783
3/8-32	0.285	1.000	0.235	0.016	0.375	3.50	3	TMLR285-32EL	TMLR285-32ELA	110720	110786
7/16-14	0.340	0.800	0.235	0.036	0.375	3.50	3	TMLR340-14	TMLR340-14A	110723	110789
7/16-14	0.340	1.200	0.235	0.036	0.375	3.50	3	TMLR340-14EL	TMLR340-14ELA	110726	110792
7/16-18	0.340	0.800	0.258	0.028	0.375	3.50	3	TMLR340-18	TMLR340-18A	110729	110795
7/16-18	0.340	1.200	0.258	0.028	0.375	3.50	3	TMLR340-18EL	TMLR340-18ELA	110732	110798
7/16-20	0.340	0.800	0.265	0.025	0.375	3.50	3	TMLR340-20	TMLR340-20A	110735	110801
7/16-20	0.340	1.200	0.265	0.025	0.375	3.50	3	TMLR340-20EL	TMLR340-20ELA	110738	110804
1/2-12	0.370	0.800	0.245	0.042	0.375	3.50	3	TMLR370-12	TMLR370-12A	110741	110807
1/2-12	0.370	1.200	0.245	0.042	0.375	3.50	3	TMLR370-12EL	TMLR370-12ELA	110744	110810
1/2-13	0.370	0.800	0.255	0.038	0.375	3.50	3	TMLR370-13	TMLR370-13A	110747	110813
1/2-13	0.370	1.200	0.255	0.038	0.375	3.50	3	TMLR370-13EL	TMLR370-13ELA	110750	110816
1/2-18	0.370	0.800	0.287	0.028	0.375	3.50	3	TMLR370-18	TMLR370-18A	110753	110819
1/2-18	0.370	1.200	0.287	0.028	0.375	3.50	3	TMLR370-18EL	TMLR370-18ELA	110756	110822
1/2-20	0.370	0.800	0.295	0.025	0.375	3.50	3	TMLR370-20	TMLR370-20A	110759	110825
1/2-20	0.370	1.200	0.295	0.025	0.375	3.50	3	TMLR370-20EL	TMLR370-20ELA	110762	110828
1/2-32	0.370	0.800	0.315	0.016	0.375	3.50	3	TMLR370-32	TMLR370-32A	110765	110831
1/2-32	0.370	1.200	0.315	0.016	0.375	3.50	3	TMLR370-32EL	TMLR370-32ELA	110768	110834
5/8-11	0.470	1.200	0.335	0.045	0.500	4.00	4	TMLR470-11	TMLR470-11A	110837	110861
5/8-11	0.470	1.750	0.335	0.045	0.500	4.00	4	TMLR470-11EL	TMLR470-11ELA	110840	110864
3/4-10	0.495	1.200	0.345	0.050	0.500	4.00	4	TMLR495-10	TMLR495-10A	110843	110867
3/4-10	0.495	1.750	0.345	0.050	0.500	4.00	4	TMLR495-10EL	TMLR495-10ELA	110846	110870
3/4-12	0.495	1.200	0.370	0.042	0.500	4.00	4	TMLR495-12	TMLR495-12A	110849	110873
3/4-12	0.495	1.750	0.370	0.042	0.500	4.00	4	TMLR495-12EL	TMLR495-12ELA	110852	110876
3/4-16	0.495	1.200	0.395	0.031	0.500	4.00	4	TMLR495-16	TMLR495-16A	110855	110879
3/4-16	0.495	1.750	0.395	0.031	0.500	4.00	4	TMLR495-16EL	TMLR495-16ELA	110858	110882

***Single profile thread mills can cut any larger size internal thread within the recommended TPI**

[Go to Thread Mill Overview](#)

UN THREAD MILLS

STRAIGHT FLUTE - SOLID CARBIDE

FULL PROFILE

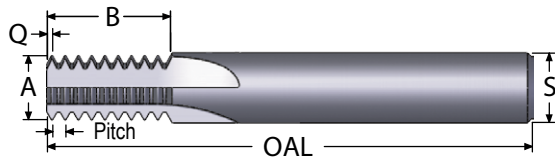

- Optional short length-of-cut for ideal length-to-diameter ratio
- Cuts UNC, UNF, UNEF, UNS, and UNJ (internal only)
- Internal crest cutting design provides strongest possible tooling

MIN ID THREAD/ PITCH*	"A" TOOL DIA.	"B" LENGTH OF CUT	"Q" LENGTH	"S" SHANK DIA.	OAL	FLUTES	ORDER #		EDP #	
							UNCOATED	ALTiN+	UNCOATED	ALTiN+
INTERNAL THREADS ONLY										
4-40	0.080	0.210	0.011	0.250	2.50	3	TM080-40	TM080-40A	101501	101675
4-40	0.080	0.136	0.011	0.250	2.50	3	TM080-40S	TM080-40SA	102051	102189
6-32	0.098	0.263	0.013	0.250	2.50	3	TM098-32	TM098-32A	101504	101678
6-32	0.098	0.201	0.013	0.250	2.50	3	TM098-32S	TM098-32SA	102054	102192
6-40	0.098	0.260	0.011	0.250	2.50	3	TM098-40	TM098-40A	101507	101681
6-40	0.098	0.186	0.011	0.250	2.50	3	TM098-40S	TM098-40SA	102057	102195
8-32	0.110	0.325	0.013	0.250	2.50	3	TM110-32	TM110-32A	101510	101684
8-32	0.110	0.232	0.013	0.250	2.50	3	TM110-32S	TM110-32SA	102060	102198
8-36	0.110	0.345	0.012	0.250	2.50	3	TM110-36	TM110-36A	101513	101687
8-36	0.110	0.234	0.012	0.250	2.50	3	TM110-36S	TM110-36SA	102063	102201
8-24	0.125	0.350	0.017	0.250	2.50	3	TM125-24	TM125-24A	101516	101690
8-24	0.125	0.226	0.017	0.250	2.50	3	TM125-24S	TM125-24SA	102066	102204
8-32	0.125	0.355	0.013	0.250	2.50	3	TM125-32	TM125-32A	101519	101693
8-32	0.125	0.232	0.013	0.250	2.50	3	TM125-32S	TM125-32SA	102069	102207
10-24	0.140	0.392	0.017	0.250	2.50	3	TM140-24	TM140-24A	101522	101696
10-24	0.140	0.268	0.017	0.250	2.50	3	TM140-24S	TM140-24SA	102072	102210
10-28	0.140	0.409	0.015	0.250	2.50	3	TM140-28	TM140-28A	101525	101699
10-28	0.140	0.265	0.015	0.250	2.50	3	TM140-28S	TM140-28SA	102075	102213
10-32	0.140	0.388	0.013	0.250	2.50	3	TM140-32	TM140-32A	101528	101702
10-32	0.140	0.263	0.013	0.250	2.50	3	TM140-32S	TM140-32SA	102078	102216
10-48	0.140	0.383	0.009	0.250	2.50	3	TM140-48	TM140-48A	101531	101705
10-48	0.140	0.259	0.009	0.250	2.50	3	TM140-48S	TM140-48SA	102081	102219
1/4-20	0.170	0.570	0.021	0.250	2.50	3	TM170-20	TM170-20A	101534	101708
1/4-20	0.170	0.371	0.021	0.250	2.50	3	TM170-20S	TM170-20SA	102084	102222
1/4-24	0.170	0.559	0.017	0.250	2.50	3	TM170-24	TM170-24A	101537	101711
1/4-24	0.170	0.393	0.017	0.250	2.50	3	TM170-24S	TM170-24SA	102087	102225
1/4-28	0.170	0.552	0.015	0.250	2.50	3	TM170-28	TM170-28A	101540	101714
1/4-28	0.170	0.372	0.015	0.250	2.50	3	TM170-28S	TM170-28SA	102090	102228
1/4-32	0.170	0.545	0.013	0.250	2.50	3	TM170-32	TM170-32A	101543	101717
1/4-32	0.170	0.388	0.013	0.250	2.50	3	TM170-32S	TM170-32SA	102093	102231
1/4-36	0.170	0.540	0.012	0.250	2.50	3	TM170-36	TM170-36A	101546	101720
1/4-36	0.170	0.373	0.012	0.250	2.50	3	TM170-36S	TM170-36SA	102096	102234
1/4-20	0.187	0.570	0.021	0.250	2.50	3	TM187-20	TM187-20A	101549	101723
1/4-20	0.187	0.371	0.021	0.250	2.50	3	TM187-20S	TM187-20SA	102099	102237
1/4-24	0.187	0.559	0.017	0.250	2.50	3	TM187-24	TM187-24A	101552	101726
1/4-24	0.187	0.393	0.017	0.250	2.50	3	TM187-24S	TM187-24SA	102102	102240
1/4-28	0.187	0.551	0.015	0.250	2.50	3	TM187-28	TM187-28A	101555	101729
1/4-28	0.187	0.372	0.015	0.250	2.50	3	TM187-28S	TM187-28SA	102105	102243

*Single profile thread mills can cut any larger size internal thread within the recommended TPI

[Go to Thread Mill Overview](#)

THREAD MILLS
UN

SINGLE POINT

INDEXABLE TOOLS

PORT - CAVITY

SPECIALTY

UN THREAD MILLS

STRAIGHT FLUTE - SOLID CARBIDE

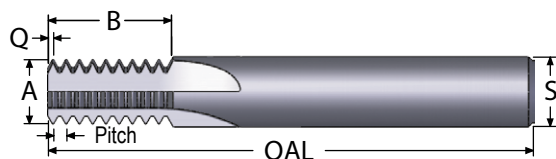

- ALTiN+ coating extends tool life
- Internal threads only
- Full Profile

MIN ID THREAD / PITCH*	"A" TOOL DIA.	"B" LENGTH OF CUT	"Q" LENGTH	"S" SHANK DIA.	OAL	FLUTES	ORDER #		EDP #	
							UNCOATED	ALTiN+	UNCOATED	ALTiN+
							INTERNAL THREADS ONLY			
1/4-32	0.187	0.545	0.013	0.250	2.50	3	TM187-32	TM187-32A	101558	101732
1/4-32	0.187	0.388	0.013	0.250	2.50	3	TM187-32S	TM187-32SA	102108	102246
1/4-36	0.187	0.540	0.012	0.250	2.50	3	TM187-36	TM187-36A	101561	101735
1/4-36	0.187	0.373	0.012	0.250	2.50	3	TM187-36S	TM187-36SA	102111	102249
1/4-40	0.187	0.560	0.011	0.250	2.50	3	TM187-40	TM187-40A	101564	101738
1/4-40	0.187	0.386	0.011	0.250	2.50	3	TM187-40S	TM187-40SA	102114	102252
1/4-48	0.187	0.551	0.009	0.250	2.50	3	TM187-48	TM187-48A	101567	101741
1/4-48	0.187	0.384	0.009	0.250	2.50	3	TM187-48S	TM187-48SA	102117	102255
5/16-18	0.235	0.689	0.023	0.250	2.50	3	TM235-18	TM235-18A	101570	101744
5/16-20	0.235	0.670	0.021	0.250	2.50	3	TM235-20	TM235-20A	101573	101747
5/16-24	0.235	0.684	0.017	0.250	2.50	3	TM235-24	TM235-24A	101576	101750
5/16-28	0.235	0.657	0.015	0.250	2.50	3	TM235-28	TM235-28A	101579	101753
5/16-32	0.235	0.669	0.013	0.250	2.50	3	TM235-32	TM235-32A	101582	101756
5/16-40	0.235	0.660	0.011	0.250	2.50	3	TM235-40	TM235-40A	101585	101759
3/8-16	0.290	0.775	0.026	0.3125	3.50	4	TM290-16	TM290-16A	101777	101792
3/8-20	0.290	0.820	0.021	0.3125	3.50	4	TM290-20	TM290-20A	101780	101795
3/8-24	0.290	0.809	0.017	0.3125	3.50	4	TM290-24	TM290-24A	101783	101798
3/8-27	0.290	0.794	0.015	0.3125	3.50	4	TM290-27	TM290-27A	101786	101801
3/8-32	0.290	0.794	0.013	0.3125	3.50	4	TM290-32	TM290-32A	101789	101804
7/16-14	0.345	0.816	0.030	0.375	3.50	4	TM345-14	TM345-14A	101807	101837
7/16-18	0.345	0.800	0.023	0.375	3.50	4	TM345-18	TM345-18A	101810	101840
7/16-20	0.345	0.821	0.021	0.375	3.50	4	TM345-20	TM345-20A	101813	101843
7/16-24	0.345	0.809	0.017	0.375	3.50	4	TM345-24	TM345-24A	101816	101846
7/16-28	0.345	0.800	0.015	0.375	3.50	4	TM345-28	TM345-28A	101819	101849
9/16-12	0.400	1.117	0.035	0.500	3.50	4	TM400-12	TM400-12A	101852	101948
1/2-13	0.400	1.108	0.032	0.500	3.50	4	TM400-13	TM400-13A	101855	101951
1/2-16	0.400	1.087	0.026	0.500	3.50	4	TM400-16	TM400-16A	101858	101954
1/2-20	0.400	1.120	0.021	0.500	3.50	4	TM400-20	TM400-20A	101861	101957
1/2-24	0.400	1.100	0.017	0.500	3.50	4	TM400-24	TM400-24A	101864	101960
1/2-28	0.400	1.087	0.015	0.500	3.50	4	TM400-28	TM400-28A	101867	101963
1/2-32	0.400	1.106	0.013	0.500	3.50	4	TM400-32	TM400-32A	101870	101966
3/4-10	0.450	1.140	0.042	0.500	3.50	4	TM450-10	TM450-10A	101873	101969
5/8-11	0.450	1.127	0.039	0.500	3.50	4	TM450-11	TM450-11A	101876	101972
5/8-12	0.450	1.117	0.035	0.500	3.50	4	TM450-12	TM450-12A	101879	101975
9/16-16	0.450	1.087	0.026	0.500	3.50	4	TM450-16	TM450-16A	101882	101978
9/16-18	0.450	1.134	0.023	0.500	3.50	4	TM450-18	TM450-18A	101885	101981
9/16-20	0.450	1.120	0.021	0.500	3.50	4	TM450-20	TM450-20A	101888	101984
3/4-12	0.490	1.117	0.035	0.500	3.50	6	TM490-12	TM490-12A	101891	101987
5/8-14	0.490	1.100	0.030	0.500	3.50	6	TM490-14	TM490-14A	101894	101990
5/8-16	0.490	1.087	0.026	0.500	3.50	6	TM490-16	TM490-16A	101897	101993
1.0-8	0.620	1.177	0.052	0.625	3.50	6	TM620-8	TM620-8A	102005	102035
7/8-9	0.620	1.157	0.046	0.625	3.50	6	TM620-9	TM620-9A	102008	102038
7/8-12	0.620	1.117	0.035	0.625	3.50	6	TM620-12	TM620-12A	101996	102026
7/8-14	0.620	1.100	0.030	0.625	3.50	6	TM620-14	TM620-14A	101999	102029
7/8-16	0.620	1.087	0.026	0.625	3.50	6	TM620-16	TM620-16A	102002	102032

*Single profile thread mills can cut any larger size internal thread within the recommended TPI

UN THREAD MILLS

COOLANT THROUGH - SOLID CARBIDE

FULL PROFILE

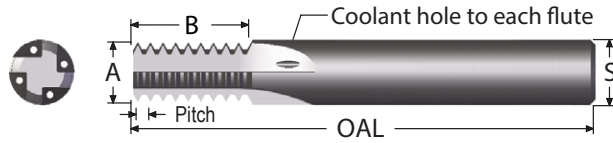

- ALTiN+ coating for higher cutting speed
- Coolant to each flute
- Cuts UNC, UNF, UNEF, and UNS threads
- Cuts UNJ threads (internal only)

MIN ID THREAD /PITCH*	"A" TOOL DIA.	"B" LENGTH OF CUT	"Q" LENGTH	"S" SHANK DIA.	OAL	FLUTES	ORDER #		EDP #	
							UNCOATED	AITIN	UNCOATED	AITIN
							INTERNAL THREADS ONLY			
4-40	0.080	0.210	0.011	0.250	2.50	3	TMC080-40	TMC080-40A	102301	102355
6-32	0.098	0.263	0.013	0.250	2.50	3	TMC098-32	TMC098-32A	102304	102358
6-40	0.098	0.260	0.011	0.250	2.50	3	TMC098-40	TMC098-40A	102307	102361
8-32	0.125	0.355	0.013	0.250	2.50	3	TMC125-32	TMC125-32A	102310	102364
10-24	0.140	0.392	0.017	0.250	2.50	3	TMC140-24	TMC140-24A	102313	102367
10-28	0.140	0.409	0.015	0.250	2.50	3	TMC140-28	TMC140-28A	102316	102370
10-32	0.140	0.388	0.013	0.250	2.50	3	TMC140-32	TMC140-32A	102319	102373
10-48	0.140	0.383	0.009	0.250	2.50	3	TMC140-48	TMC140-48A	102322	102376
1/4-20	0.170	0.570	0.021	0.250	2.50	3	TMC170-20	TMC170-20A	102325	102379
1/4-28	0.170	0.552	0.015	0.250	2.50	3	TMC170-28	TMC170-28A	102328	102382
1/4-32	0.170	0.545	0.013	0.250	2.50	3	TMC170-32	TMC170-32A	102331	102385
1/4-36	0.170	0.540	0.012	0.250	2.50	3	TMC170-36	TMC170-36A	102334	102388
5/16-18	0.235	0.689	0.023	0.250	2.50	3	TMC235-18	TMC235-18A	102337	102391
5/16-20	0.235	0.670	0.021	0.250	2.50	3	TMC235-20	TMC235-20A	102340	102394
5/16-24	0.235	0.684	0.017	0.250	2.50	3	TMC235-24	TMC235-24A	102343	102397
5/16-28	0.235	0.657	0.015	0.250	2.50	3	TMC235-28	TMC235-28A	102346	102400
5/16-32	0.235	0.669	0.013	0.250	2.50	3	TMC235-32	TMC235-32A	102349	102403
5/16-40	0.235	0.660	0.011	0.250	2.50	3	TMC235-40	TMC235-40A	102352	102406
3/8-16	0.290	0.775	0.026	0.3125	3.50	4	TMC290-16	TMC290-16A	102409	102418
3/8-20	0.290	0.820	0.021	0.3125	3.50	4	TMC290-20	TMC290-20A	102412	102421
3/8-24	0.290	0.809	0.017	0.3125	3.50	4	TMC290-24	TMC290-24A	102415	102424
7/16-14	0.345	0.816	0.030	0.375	3.50	4	TMC345-14	TMC345-14A	102427	102439
7/16-18	0.345	0.800	0.023	0.375	3.50	4	TMC345-18	TMC345-18A	102430	102442
7/16-20	0.345	0.821	0.021	0.375	3.50	4	TMC345-20	TMC345-20A	102433	102445
7/16-28	0.345	0.800	0.015	0.375	3.50	4	TMC345-28	TMC345-28A	102436	102448
1/2-13	0.400	1.108	0.032	0.500	3.50	4	TMC400-13	TMC400-13A	102451	102481
1/2-20	0.400	1.120	0.021	0.500	3.50	4	TMC400-20	TMC400-20A	102454	102484
1/2-28	0.400	1.087	0.015	0.500	3.50	4	TMC400-28	TMC400-28A	102457	102487
1/2-32	0.400	1.106	0.013	0.500	3.50	4	TMC400-32	TMC400-32A	102460	102490

*Single profile thread mills can cut any larger size internal thread within the recommended TPI

[Go to Thread Mill Overview](#)

THREAD MILLS UN

SINGLE POINT

INDEXABLE TOOLS

PORT - CAVITY

SPECIALTY

UN THREAD MILLS

COOLANT THROUGH - SOLID CARBIDE

FULL PROFILE

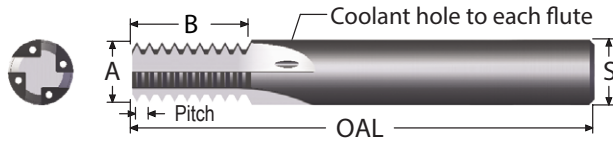

- ALTiN+ coating for higher cutting speed
- Coolant to each flute
- Cuts UNC, UNF, UNEF, and UNS threads
- Cuts UNJ threads (internal only)

MIN ID THREAD / PITCH*	"A" TOOL DIA.	"B" LENGTH OF CUT	"Q" LENGTH	"S" SHANK DIA.	OAL	FLUTES	ORDER #		EDP #	
							UNCOATED	ALTiN+	UNCOATED	ALTiN+
							INTERNAL THREADS ONLY			
3/4-10	0.450	1.140	0.042	0.500	3.50	4	TMC450-10	TMC450-10A	102463	102493
5/8-11	0.450	1.127	0.039	0.500	3.50	4	TMC450-11	TMC450-11A	102466	102496
5/8-12	0.450	1.117	0.035	0.500	3.50	4	TMC450-12	TMC450-12A	102469	102499
9/16-16	0.450	1.087	0.026	0.500	3.50	4	TMC450-16	TMC450-16A	102472	102502
9/16-18	0.450	1.134	0.023	0.500	3.50	4	TMC450-18	TMC450-18A	102475	102505
9/16-20	0.450	1.120	0.021	0.500	3.50	4	TMC450-20	TMC450-20A	102478	102508
7/8-12	0.620	1.117	0.035	0.625	3.50	6	TMC620-12	TMC620-12A	102511	102520
7/8-14	0.620	1.100	0.030	0.625	3.50	6	TMC620-14	TMC620-14A	102514	102523
7/8-16	0.620	1.087	0.026	0.625	3.50	6	TMC620-16	TMC620-16A	102517	102526

*Thread mills can cut any larger size internal thread of the same pitch

UN THREAD MILLS

COOLANT THROUGH - CARBIDE TIPPED

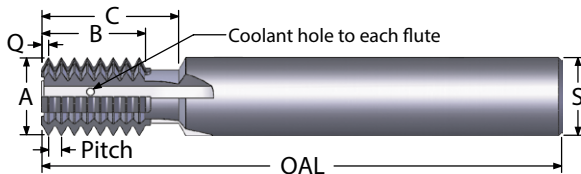

- ALTiN+ coating for higher cutting speed
- Coolant to each flute
- Cuts UNC, UNF, UNEF, and UNS threads
- Cuts UNJ threads (internal only)

MIN ID THREAD / PITCH*	"A" TOOL DIA.	"B" LENGTH OF CUT	"C" TOOL REACH	"Q" LENGTH	"S" SHANK DIA.	OAL	FLUTES	ORDER #		EDP #	
								UNCOATED	ALTiN	UNCOATED	ALTiN+
								INTERNAL OR EXTERNAL THREADS			
1¼-7	0.740	1.130	1.370	0.065	0.750	6.00	4	TMC740-7	TMC740-7A	102541	102577
1-8	0.740	1.122	1.370	0.057	0.750	6.00	4	TMC740-8	TMC740-8A	102544	102580
1-12	0.740	1.076	1.370	0.038	0.750	6.00	4	TMC740-12	TMC740-12A	102529	102565
1-14	0.740	1.135	1.370	0.032	0.750	6.00	4	TMC740-14	TMC740-14A	102532	102568
1-16	0.740	1.119	1.370	0.028	0.750	6.00	4	TMC740-16	TMC740-16A	102535	102571
1-20	0.740	1.096	1.370	0.023	0.750	6.00	4	TMC740-20	TMC740-20A	102538	102574
1½-6	0.990	1.152	2.000	0.076	1.000	6.00	6	TMC990-6	TMC990-6A	102589	102613
1½-8	0.990	1.122	2.000	0.061	1.000	6.00	6	TMC990-8	TMC990-8A	102592	102616
1½-12	0.990	1.166	2.000	0.041	1.000	6.00	6	TMC990-12	TMC990-12A	102583	102607
1½-16	0.990	1.122	2.000	0.029	1.000	6.00	6	TMC990-16	TMC990-16A	102586	102610

*Thread mills can cut any larger size internal thread of the same pitch

[Go to Thread Mill Overview](#)

UN THREAD MILLS - STAGGERED TOOTH

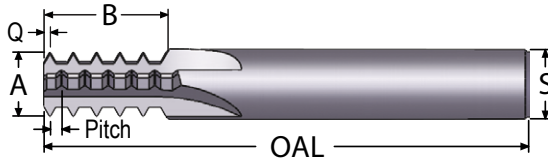

- Staggered tooth design reduces tool pressure
- Non-crest cutting for max thread size adjustability

STRAIGHT FLUTE - STAGGERED TOOTH - SOLID CARBIDE

MIN ID THREAD / PITCH*	"A" TOOL DIA.	"B" LENGTH OF CUT	"Q" LENGTH	"S" SHANK DIA.	OAL	FLUTES	ORDER #		EDP #	
							UNCOATED	ALTiN+	UNCOATED	ALTiN+
<i>INTERNAL OR EXTERNAL THREADS</i>										
3/8-20	0.250	0.675	0.027	0.250	2.50	4	TM250-20	TM250-20A	102651	102687
3/8-24	0.250	0.687	0.024	0.250	2.50	4	TM250-24	TM250-24A	102654	102690
3/8-28	0.250	0.661	0.020	0.250	2.50	4	TM250-28	TM250-28A	102657	102693
3/8-32	0.250	0.672	0.017	0.250	2.50	4	TM250-32	TM250-32A	102660	102696
3/8-36	0.250	0.682	0.016	0.250	2.50	4	TM250-36	TM250-36A	102663	102699
3/8-40	0.250	0.662	0.014	0.250	2.50	4	TM250-40	TM250-40A	102666	102702

*Thread mills can cut any larger size internal thread of the same pitch

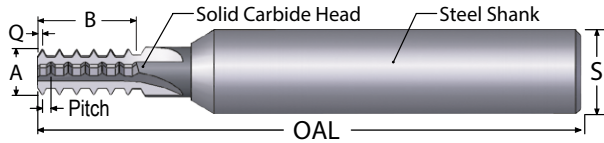

- Cuts UNC, UNF, UNEF, and UNS threads
- Cuts UNJ threads (internal only)
- Non-crest cutting design cuts internal and external threads

STRAIGHT FLUTE - STAGGERED TOOTH - CARBIDE HEAD

MIN ID THREAD / PITCH*	"A" TOOL DIA.	"B" LENGTH OF CUT	"Q" LENGTH	"S" SHANK DIA.	OAL	FLUTES	ORDER #		EDP #	
							UNCOATED	ALTiN+	UNCOATED	ALTiN+
<i>INTERNAL OR EXTERNAL THREADS</i>										
7/16-16	0.350	0.783	0.036	0.750	6.00	4	TM350-16	TM350-16A	102705	102747
7/16-18	0.350	0.807	0.032	0.750	6.00	4	TM350-18	TM350-18A	102708	102750
7/16-20	0.350	0.823	0.027	0.750	6.00	4	TM350-20	TM350-20A	102711	102753
7/16-24	0.350	0.856	0.024	0.750	6.00	4	TM350-24	TM350-24A	102714	102756
5/8-12	0.500	1.042	0.046	0.750	6.00	4	TM500-12	TM500-12A	102717	102759
5/8-14	0.500	1.037	0.040	0.750	6.00	4	TM500-14	TM500-14A	102720	102762
5/8-16	0.500	1.033	0.036	0.750	6.00	4	TM500-16	TM500-16A	102723	102765

*Thread mills can cut any larger size internal thread of the same pitch

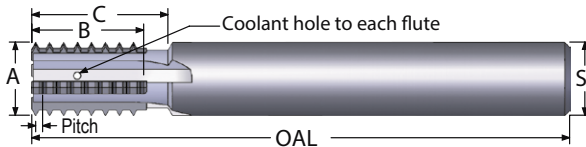

- ALTiN+ coating extends tool life
- Ideal for plated thread applications

COOLANT THROUGH THREAD MILLS STRAIGHT FLUTE - STAGGERED TOOTH - CARBIDE TIPPED

MIN ID THREAD / PITCH*	"A" TOOL DIA.	"B" LENGTH OF CUT	"C" TOOL REACH	"Q" LENGTH	"S" SHANK DIA.	OAL	FLUTES	ORDER #		EDP #	
								UNCOATED	ALTiN+	UNCOATED	ALTiN+
<i>INTERNAL OR EXTERNAL THREADS</i>											
1-12	0.750	1.176	1.370	0.048	0.750	6.00	4	TMC750-12	TMC750-12A	102801	102825
1-14	0.750	1.152	1.370	0.042	0.750	6.00	4	TMC750-14	TMC750-14A	102804	102828
1-18	0.750	1.117	1.370	0.032	0.750	6.00	4	TMC750-18	TMC750-18A	102807	102831
1-20	0.750	1.106	1.370	0.029	0.750	6.00	4	TMC750-20	TMC750-20A	102810	102834
1½-12	1.000	1.176	2.000	0.047	1.000	6.00	6	TMC1000-12	TMC1000-12A	102837	102849
1½-16	1.000	1.196	2.000	0.037	1.000	6.00	6	TMC1000-16	TMC1000-16A	102840	102852

*Thread mills can cut any larger size internal thread of the same pitch

[Go to Thread Mill Overview](#)

THREAD MILLS UN
SINGLE POINT
INDEXABLE TOOLS
PORT - CAVITY
SPECIALTY

UN THREAD MILLS

15° HELICAL FLUTE SOLID CARBIDE

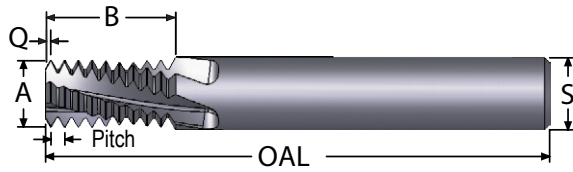

- Cuts UNC, UNF, UNEF, UNS and UNJ (internal only)
- Non-crest cutting allows maximum flexibility for plated and non-standard threads
- Long length-of-cut

MIN ID THREAD / PITCH*	"A" TOOL DIA.	"B" LENGTH OF CUT	"Q" LENGTH	"S" SHANK DIA.	OAL	FLUTES	ORDER #		EDP #	
							UNCOATED	ALTiN+	UNCOATED	ALTiN+
							INTERNAL THREADS ONLY			
4-40	0.079	0.185	0.011	0.250	2.50	2	TMI079-40H	TMI079-40HA	102901	102937
6-32	0.100	0.263	0.014	0.250	2.50	3	TMI100-32H	TMI100-32HA	102904	102940
8-32	0.115	0.263	0.014	0.250	2.50	3	TMI115-32H	TMI115-32HA	102907	102943
10-24	0.120	0.351	0.019	0.250	2.50	3	TMI120-24H	TMI120-24HA	102910	102946
10-28	0.120	0.336	0.016	0.250	2.50	3	TMI120-28H	TMI120-28HA	102913	102949
10-32	0.120	0.326	0.014	0.250	2.50	3	TMI120-32H	TMI120-32HA	102916	102952
1/4-20	0.180	0.521	0.023	0.250	2.50	3	TMI180-20H	TMI180-20HA	102919	102955
1/4-28	0.180	0.515	0.016	0.250	2.50	3	TMI180-28H	TMI180-28HA	102922	102958
5/16-18	0.234	0.632	0.025	0.250	2.50	3	TMI234-18H	TMI234-18HA	102925	102961
5/16-24	0.234	0.641	0.019	0.250	2.50	3	TMI234-24H	TMI234-24HA	102928	102964
5/16-32	0.234	0.638	0.014	0.250	2.50	3	TMI234-32H	TMI234-32HA	102931	102967
5/16-40	0.234	0.635	0.011	0.250	2.50	3	TMI234-40H	TMI234-40HA	102934	102970
3/8-16	0.285	0.775	0.028	0.3125	3.00	4	TMI285-16H	TMI285-16HA	102973	102988
3/8-20	0.285	0.770	0.023	0.3125	3.00	4	TMI285-20H	TMI285-20HA	102976	102991
3/8-24	0.285	0.766	0.019	0.3125	3.00	4	TMI285-24H	TMI285-24HA	102979	102994
3/8-32	0.285	0.763	0.014	0.3125	3.00	4	TMI285-32H	TMI285-32HA	102982	102997
7/16-14	0.305	0.886	0.032	0.3125	3.00	4	TMI305-14H	TMI305-14HA	102985	103000
7/16-18	0.335	0.888	0.025	0.375	3.00	4	TMI335-18H	TMI335-18HA	103003	103021
7/16-20	0.335	0.870	0.023	0.375	3.00	4	TMI335-20H	TMI335-20HA	103006	103024
1/2-13	0.350	0.877	0.035	0.375	3.00	4	TMI350-13H	TMI350-13HA	103009	103027
9/16-12	0.370	0.867	0.038	0.375	3.00	4	TMI370-12H	TMI370-12HA	103012	103030
9/16-18	0.370	0.911	0.025	0.375	3.00	4	TMI370-18H	TMI370-18HA	103015	103033
9/16-32	0.370	0.888	0.014	0.375	3.00	4	TMI370-32H	TMI370-32HA	103018	103036
5/8-11	0.470	1.309	0.041	0.500	4.00	4	TMI470-11H	TMI470-11HA	103039	103063
3/4-10	0.495	1.340	0.045	0.500	4.00	4	TMI495-10H	TMI495-10HA	103042	103066
3/4-12	0.495	1.283	0.038	0.500	4.00	4	TMI495-12H	TMI495-12HA	103045	103069
3/4-14	0.495	1.314	0.032	0.500	4.00	4	TMI495-14H	TMI495-14HA	103048	103072
3/4-16	0.495	1.338	0.028	0.500	4.00	4	TMI495-16H	TMI495-16HA	103051	103075
3/4-18	0.495	1.300	0.025	0.500	4.00	4	TMI495-18H	TMI495-18HA	103054	103078
3/4-20	0.495	1.320	0.023	0.500	4.00	4	TMI495-20H	TMI495-20HA	103057	103081
3/4-32	0.495	1.325	0.014	0.500	4.00	4	TMI495-32H	TMI495-32HA	103060	103084
7/8-9	0.620	1.489	0.049	0.625	4.00	5	TMI620-9H	TMI620-9HA	103099	103114
1.0-8	0.620	1.550	0.056	0.625	4.00	5	TMI620-8H	TMI620-8HA	103096	103111
1.0-12	0.620	1.534	0.038	0.625	4.00	5	TMI620-12H	TMI620-12HA	103087	103102
1.0-14	0.620	1.529	0.032	0.625	4.00	5	TMI620-14H	TMI620-14HA	103090	103105
1.0-16	0.620	1.525	0.028	0.625	4.00	5	TMI620-16H	TMI620-16HA	103093	103108

*Thread mills can cut any larger size internal thread of the same pitch

[Go to Thread Mill Overview](#)

UN THREAD MILLS

30° HELICAL FLUTE SOLID CARBIDE

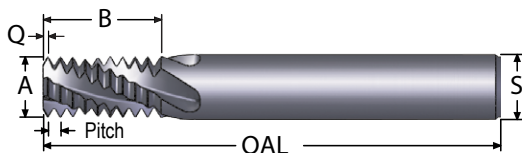

- Helical flute for reduced side cutting pressure
- Non-crest cutting on the internal thread allows maximum flexibility for plated and non-standard threads

MIN ID THREAD / PITCH*	"A" TOOL DIA.	"B" LENGTH OF CUT	"Q" LENGTH	"S" SHANK DIA.	OAL	FLUTES	ORDER #		EDP #	
							UNCOATED	ALTiN+	UNCOATED	ALTiN+
<i>INTERNAL OR EXTERNAL THREADS</i>										
10-24	0.125	0.350	0.019	0.250	2.50	3	TM125-24H	TM125-24HA	103204	103348
10-24	0.140	0.392	0.019	0.250	2.50	3	TM140-24H	TM140-24HA	103210	103354
10-28	0.140	0.407	0.016	0.250	2.50	3	TM140-28H	TM140-28HA	103213	103357
10-32	0.140	0.388	0.014	0.250	2.50	3	TM140-32H	TM140-32HA	103216	103360
10-48	0.140	0.383	0.009	0.250	2.50	3	TM140-48H	TM140-48HA	103219	103363
1/4-20	0.170	0.520	0.023	0.250	2.50	3	TM170-20H	TM170-20HA	103222	103366
1/4-24	0.170	0.517	0.019	0.250	2.50	3	TM170-24H	TM170-24HA	103225	103369
1/4-28	0.170	0.514	0.016	0.250	2.50	3	TM170-28H	TM170-28HA	103228	103372
1/4-32	0.170	0.513	0.014	0.250	2.50	3	TM170-32H	TM170-32HA	103231	103375
1/4-36	0.170	0.511	0.013	0.250	2.50	3	TM170-36H	TM170-36HA	103234	103378
1/4-20	0.187	0.520	0.023	0.250	2.50	3	TM187-20H	TM187-20HA	103237	103381
1/4-24	0.187	0.517	0.019	0.250	2.50	3	TM187-24H	TM187-24HA	103240	103384
1/4-28	0.187	0.514	0.016	0.250	2.50	3	TM187-28H	TM187-28HA	103243	103387
1/4-32	0.187	0.513	0.014	0.250	2.50	3	TM187-32H	TM187-32HA	103246	103390
1/4-36	0.187	0.511	0.013	0.250	2.50	3	TM187-36H	TM187-36HA	103249	103393
1/4-40	0.187	0.511	0.011	0.250	2.50	3	TM187-40H	TM187-40HA	103252	103396
5/16-18	0.235	0.689	0.025	0.250	2.50	3	TM235-18H	TM235-18HA	103255	103399
5/16-20	0.235	0.670	0.023	0.250	2.50	3	TM235-20H	TM235-20HA	103258	103402
5/16-24	0.235	0.684	0.019	0.250	2.50	3	TM235-24H	TM235-24HA	103261	103405
5/16-28	0.235	0.657	0.016	0.250	2.50	3	TM235-28H	TM235-28HA	103264	103408
5/16-32	0.235	0.669	0.014	0.250	2.50	3	TM235-32H	TM235-32HA	103267	103411
5/16-40	0.235	0.660	0.011	0.250	2.50	3	TM235-40H	TM235-40HA	103270	103414
3/8-16	0.290	0.775	0.028	0.3125	3.50	4	TM290-16H	TM290-16HA	103417	103447
3/8-20	0.290	0.820	0.023	0.3125	3.50	4	TM290-20H	TM290-20HA	103420	103450
3/8-24	0.290	0.808	0.019	0.3125	3.50	4	TM290-24H	TM290-24HA	103423	103453
3/8-27	0.290	0.793	0.017	0.3125	3.50	4	TM290-27H	TM290-27HA	103426	103456
3/8-32	0.290	0.794	0.014	0.3125	3.50	4	TM290-32H	TM290-32HA	103429	103459
7/16-14	0.345	0.814	0.032	0.375	3.50	4	TM345-14H	TM345-14HA	103462	103492
7/16-18	0.345	0.800	0.025	0.375	3.50	4	TM345-18H	TM345-18HA	103465	103495
7/16-20	0.345	0.820	0.023	0.375	3.50	4	TM345-20H	TM345-20HA	103468	103498
7/16-24	0.345	0.808	0.019	0.375	3.50	4	TM345-24H	TM345-24HA	103471	103501
7/16-28	0.345	0.800	0.016	0.375	3.50	4	TM345-28H	TM345-28HA	103474	103504
9/16-12	0.400	1.117	0.038	0.500	3.50	4	TM400-12H	TM400-12HA	103507	103585
1/2-13	0.400	1.108	0.035	0.500	3.50	4	TM400-13H	TM400-13HA	103510	103588
1/2-16	0.400	1.088	0.028	0.500	3.50	4	TM400-16H	TM400-16HA	103513	103591
1/2-20	0.400	1.120	0.023	0.500	3.50	4	TM400-20H	TM400-20HA	103516	103594
1/2-24	0.400	1.100	0.019	0.500	3.50	4	TM400-24H	TM400-24HA	103519	103597
1/2-28	0.400	1.086	0.016	0.500	3.50	4	TM400-28H	TM400-28HA	103522	103600
1/2-32	0.400	1.106	0.014	0.500	3.50	4	TM400-32H	TM400-32HA	103525	103603
3/4-10	0.450	1.140	0.045	0.500	3.50	4	TM450-10H	TM450-10HA	103528	103606
5/8-11	0.450	1.127	0.041	0.500	3.50	4	TM450-11H	TM450-11HA	103531	103609
5/8-12	0.450	1.117	0.038	0.500	3.50	4	TM450-12H	TM450-12HA	103534	103612
9/16-16	0.450	1.088	0.028	0.500	3.50	4	TM450-16H	TM450-16HA	103537	103615
9/16-18	0.450	1.078	0.025	0.500	3.50	4	TM450-18H	TM450-18HA	103540	103618
9/16-20	0.450	1.120	0.023	0.500	3.50	4	TM450-20H	TM450-20HA	103543	103621

*Thread mills can cut any larger size internal thread of the same pitch

THREAD MILLS
UN

SINGLE POINT

INDEXABLE TOOLS

PORT - CAVITY

SPECIALTY

THREAD MILLS - NPT - STRAIGHT FLUTE SOLID CARBIDE (NATIONAL PIPE TAPER)

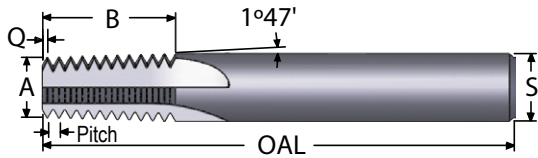

- Made with premium submicron grade carbide
- ALTiN+ coated for higher cutting speed

STRAIGHT FLUTE - NPT

THREAD DIA. / PITCH	"A" TOOL DIA.	"B" LENGTH OF CUT	"Q" LENGTH	"S" SHANK DIA.	OAL	FLUTES	ORDER #		EDP #	
							UNCOATED	ALTiN+	UNCOATED	ALTiN+
							INTERNAL OR EXTERNAL THREADS			
1/16, 1/8-27	0.218	0.534	0.018	0.2500	2.50	4	TM218-27NPT	TM218-27NPT-A	101001	101013
1/8-27	0.280	0.758	0.018	0.3750	3.50	4	TM280-27NPT	TM280-27NPT-A	101019	101043
1/4, 3/8-18	0.330	0.693	0.027	0.3750	3.50	4	TM330-18NPT	TM330-18NPT-A	101025	101049
1/4, 3/8-18	0.382	0.800	0.027	0.4375	3.50	4	TM382-18NPT	TM382-18NPT-A	101055	101067
1/2, 3/4-14	0.430	1.105	0.035	0.5000	3.50	4	TM430-14NPT	TM430-14NPT-A	101073	101085
1 to 2-11½	0.650	1.605	0.043	0.7500	4.00	5	TM650-11.5NPT	TM650-11.5NPT-A	101091	101109
2½ up-8	0.650	1.560	0.062	0.7500	4.00	5	TM650-8NPT	TM650-8NPT-A	101097	101115

For increased performance, use with tapered pipe reamer on page 103.

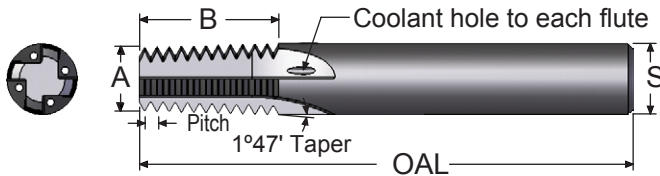

- Coolant to each flute
- Cuts internal or external threads

COOLANT THROUGH STRAIGHT FLUTE - NPT

MIN IN THREAD/ PITCH	"A" TOOL DIA.	"B" LENGTH OF CUT	"Q" LENGTH	"S" SHANK DIA.	OAL	FLUTES	ORDER #		EDP #	
							UNCOATED	ALTiN+	UNCOATED	ALTiN+
							INTERNAL OR EXTERNAL THREADS			
1/16, 1/8-27	0.218	0.534	0.018	0.250	2.50	3	TMC218-27NPT	TMC218-27NPT-A	101151	101154
1/4, 3/8-18	0.330	0.693	0.027	0.375	3.50	4	TMC330-18NPT	TMC330-18NPT-A	101157	101160
1/2, 3/4-14	0.430	1.105	0.035	0.500	3.50	4	TMC430-14NPT	TMC430-14NPT-A	101163	101166
1 to 2-11½	0.550	1.172	0.043	0.625	3.50	6	TMC550-11.5NPT	TMC550-11.5NPT-A	101169	101172

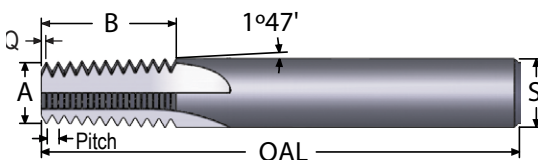

- ALTiN+ coating for improved surface finish
- Polished flute face for optimum performance

STRAIGHT FLUTE - DRYSEAL - NPTF

THREAD DIA. / PITCH	"A" TOOL DIA.	"B" LENGTH OF CUT	"Q" LENGTH	"S" SHANK DIA.	OAL	FLUTES	ORDER #		EDP #	
							UNCOATED	ALTiN+	UNCOATED	ALTiN+
							INTERNAL OR EXTERNAL THREADS			
1/16, 1/8-27	0.218	0.534	0.018	0.250	2.50	4	TM218-27NPTF	TM218-27NPTF-A	101004	101016
1/8-27	0.280	0.758	0.018	0.375	3.50	4	TM280-27NPTF	TM280-27NPTF-A	101022	101046
1/4, 3/8-18	0.330	0.693	0.027	0.375	3.50	4	TM330-18NPTF	TM330-18NPTF-A	101028	101052
1/4, 3/8-18	0.382	0.800	0.027	0.4375	3.50	4	TM382-18NPTF	TM382-18NPTF-A	101058	101070
1/2, 3/4-14	0.430	1.105	0.035	0.500	3.50	4	TM430-14NPTF	TM430-14NPTF-A	101076	101088
1 to 2-11½	0.650	1.605	0.043	0.750	4.00	5	TM650-11.5NPTF	TM650-11.5NPTF-A	101094	101112
2½ up-8	0.650	1.560	0.062	0.750	4.00	5	TM650-8NPTF	TM650-8NPTF-A	101100	101121

[Go to Thread Mill Overview](#)

All NPT thread mills are crest cutting (full profile)

THREAD MILLS - NPT - STRAIGHT FLUTE STAGGERED TOOTH - SOLID CARBIDE (NATIONAL PIPE TAPER)

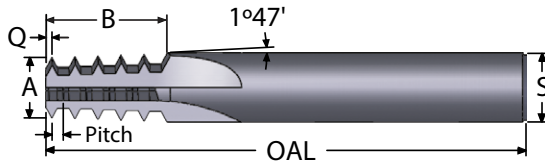

- Staggered tooth design reduces tool pressure
- ALTiN+ coating extends tool life

STRAIGHT FLUTE - STAGGERED TOOTH - NPT

THREAD DIA. / PITCH	"A" TOOL DIA.	"B" LENGTH OF CUT	"Q" LENGTH	"S" SHANK DIA.	OAL	FLUTES	ORDER #		EDP #	
							UNCOATED	ALTiN	UNCOATED	ALTiN+
<i>INTERNAL OR EXTERNAL THREADS</i>										
1/16, 1/8-27	0.220	0.534	0.019	0.250	2.50	4	TM220-27NPT	TM220-27NPT-A	101181	101193
1/8-27	0.275	0.758	0.019	0.375	3.50	4	TM275-27NPT	TM275-27NPT-A	101199	101223
1/4, 3/8-18	0.335	0.693	0.028	0.375	3.50	4	TM335-18NPT	TM335-18NPT-A	101205	101229
1/4, 3/8-18	0.387	0.805	0.028	0.4375	3.50	4	TM387-18NPT	TM387-18NPT-A	101235	101247
1/2, 3/4-14	0.435	1.034	0.036	0.500	3.50	4	TM435-14NPT	TM435-14NPT-A	101253	101265
1/2, 3/4-14	0.440	1.034	0.036	0.750	6.00	4	◆ TM440-14NPT	◆ TM440-14NPT-A	◆ 101271	◆ 101283
1¼ to 2-11½	1.000	1.742	0.044	1.000	6.00	6	▲ TM1.0-11.5NPT	▲ TM1.0-11.5NPT-A	▲ 101289	▲ 101301

For increased performance, use with tapered pipe reamer on page 103.

- ◆ Tool is steel shank with a solid carbide head
- ▲ Tool is carbide tipped with coolant hole to each flute

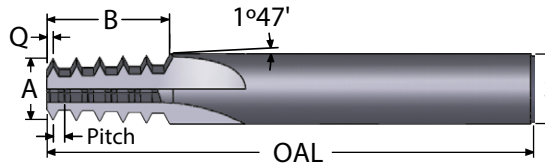

- Made from premium submicron carbide
- ALTiN+ coated tool for higher cutting speed

STRAIGHT FLUTE - STAGGERED TOOTH- DRYSEAL - NPTF

THREAD DIA. / PITCH	"A" TOOL DIA.	"B" LENGTH OF CUT	"Q" LENGTH	"S" SHANK DIA.	OAL	FLUTES	ORDER #		EDP #	
							UNCOATED	ALTiN+	UNCOATED	ALTiN+
<i>INTERNAL OR EXTERNAL THREADS</i>										
1/16, 1/8-27	0.220	0.534	0.019	0.250	2.50	4	TM220-27NPTF	TM220-27NPTF-A	101184	101196
1/8-27	0.275	0.758	0.019	0.375	3.50	4	TM275-27NPTF	TM275-27NPTF-A	101202	101226
1/4, 3/8-18	0.335	0.693	0.028	0.375	3.50	4	TM335-18NPTF	TM335-18NPTF-A	101208	101232
1/4, 3/8-18	0.387	0.805	0.028	0.4375	3.50	4	TM387-18NPTF	TM387-18NPTF-A	101238	101250
1/2, 3/4-14	0.435	1.034	0.036	0.500	3.50	4	TM435-14NPTF	TM435-14NPTF-A	101256	101268
1/2, 3/4-14	0.440	1.034	0.036	0.750	6.00	4	◆ TM440-14NPTF	◆ TM440-14NPTF-A	◆ 101274	◆ 101286
1¼ to 2-11½	1.000	1.700	0.044	1.00	6.00	6	▲ TM1.0-11.5NPTF	▲ TM1.0-11.5NPTF-A	▲ 101292	▲ 101304

- ◆ Tool is steel shank with a solid carbide head
- ▲ Tool is carbide tipped with coolant hole to each flute

All NPT thread mills are crest cutting (full profile)

[Go to Thread Mill Overview](#)

THREAD MILLS NPT

SINGLE POINT

INDEXABLE TOOLS

PORT - CAVITY

SPECIALTY

THREAD MILLS - NPT - HELICAL - CARBIDE (NATIONAL PIPE TAPER)

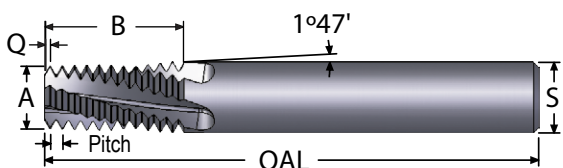

- Made with premium submicron grade carbide
- ALTiN+ coating for improved surface finish

15° HELICAL FLUTE- NPT

THREAD DIA./PITCH	"A" TOOL DIA.	"B" LENGTH OF CUT	"Q" LENGTH	"S" SHANK DIA.	OAL	FLUTES	ORDER #		EDP #	
							UNCOATED	ALTiN+	UNCOATED	ALTiN+
							INTERNAL OR EXTERNAL THREADS			
1/16, 1/8-27	0.222	0.461	0.018	0.250	2.50	3	TMX222-27-H	TMX222-27-HA	101351	101354
1/4, 3/8-18	0.270	0.636	0.027	0.312	2.50	4	TMX270-18-H	TMX270-18-HA	101357	101360
1/2, 3/4-14	0.440	0.890	0.035	0.500	4.00	4	TMX440-14-H	TMX440-14-HA	101363	101366
1" to 2"-11.5	0.550	1.171	0.043	0.625	4.00	4	TMX550-11.5-H	TMX550-11.5-HA	101369	101372

For increased performance, use with tapered pipe reamer on page 103.

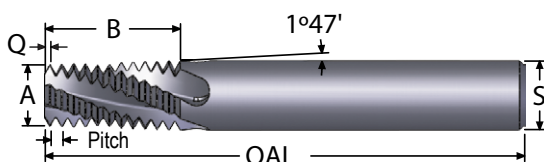

- ALTiN+ coating extends tool life
- Helical flute for reduced side cutting pressure

30° HELICAL FLUTE - NPT

THREAD DIA. / PITCH	"A" TOOL DIA.	"B" LENGTH OF CUT	"Q" LENGTH	"S" SHANK DIA.	OAL	FLUTES	ORDER #		EDP #	
							UNCOATED	ALTiN+	UNCOATED	ALTiN+
							INTERNAL OR EXTERNAL THREADS			
1/16, 1/8-27	0.218	0.534	0.018	0.250	2.50	4	TM218-27NPT-H	TM218-27NPT-HA	101404	101416
1/8-27	0.280	0.758	0.018	0.375	3.50	4	TM280-27NPT-H	TM280-27NPT-HA	101422	101446
1/4, 3/8-18	0.330	0.693	0.027	0.375	3.50	4	TM330-18NPT-H	TM330-18NPT-HA	101428	101452
1/4, 3/8-18	0.382	0.800	0.027	0.4375	3.50	4	TM382-18NPT-H	TM382-18NPT-HA	101458	101470
1/2, 3/4-14	0.430	1.105	0.035	0.500	3.50	4	TM430-14NPT-H	TM430-14NPT-HA	101476	101488

For increased performance, use with tapered pipe reamer on page 103.

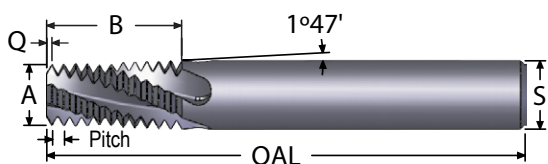

- Polished flute face for optimum performance
- ALTiN+ coated tool for higher cutting speed

30° HELICAL FLUTE - NPTF - DRYSEAL

THREAD DIA. / PITCH	"A" TOOL DIA.	"B" LENGTH OF CUT	"Q" LENGTH	"S" SHANK DIA.	OAL	FLUTES	ORDER #		EDP #	
							UNCOATED	ALTiN+	UNCOATED	ALTiN+
							INTERNAL OR EXTERNAL THREADS			
1/16, 1/8-27	0.218	0.534	0.018	0.250	2.50	4	TM218-27NPTF-H	TM218-27NPTF-HA	101401	101413
1/8-27	0.280	0.758	0.018	0.375	3.50	4	TM280-27NPTF-H	TM280-27NPTF-HA	101419	101443
1/4, 3/8-18	0.330	0.693	0.027	0.375	3.50	4	TM330-18NPTF-H	TM330-18NPTF-HA	101425	101449
1/4, 3/8-18	0.382	0.800	0.027	0.4375	3.50	4	TM382-18NPTF-H	TM382-18NPTF-HA	101455	101467
1/2, 3/4-14	0.430	1.105	0.035	0.500	3.50	4	TM430-14NPTF-H	TM430-14NPTF-HA	101473	101485

[Go to Thread Mill Overview](#)

All NPT thread mills are crest cutting (full profile)

THREAD MILLS - BSPP - SOLID CARBIDE (BRITISH STANDARD PIPE PARALLEL) FULL PROFILE

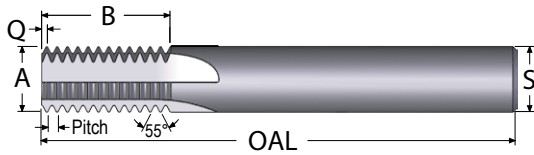

- ALTiN+ coating extends tool life
- Polished flute face for optimum performance

THREAD DIA / PITCH	"A" TOOL DIA.	"B" LENGTH OF CUT	"Q" LENGTH	"S" SHANK DIA.	OAL	FLUTES	ORDER #		EDP #	
							UNCOATED	ALTiN+	UNCOATED	ALTiN+
							INTERNAL OR EXTERNAL THREADS			
1/8-28	0.245	0.657	0.016	0.250	2.50	4	TM245-28BSPP	TM245-28BSPP-A	100004	100010
1/4, 3/8-19	0.345	0.811	0.024	0.375	3.50	4	TM345-19BSPP	TM345-19BSPP-A	100016	100022
1/2, 3/4-14	0.450	1.100	0.034	0.500	3.50	4	TM450-14BSPP	TM450-14BSPP-A	100028	100034
1 to 6-11	0.620	1.313	0.040	0.625	3.50	5	TM620-11BSPP	TM620-11BSPP-A	100040	100046

THREAD MILLS - BSPT - SOLID CARBIDE (BRITISH STANDARD PIPE TAPER) FULL PROFILE

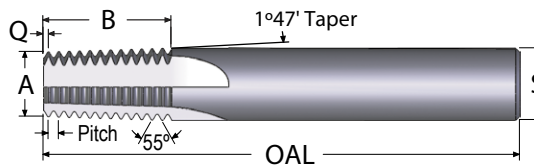

- ALTiN+ coated for improved surface finish
- Made with premium submicron grade carbide

THREAD DIA. / PITCH	"A" TOOL DIA.	"B" LENGTH OF CUT	"Q" LENGTH	"S" SHANK DIA.	OAL	FLUTES	ORDER #		EDP #	
							UNCOATED	ALTiN+	UNCOATED	ALTiN+
							INTERNAL OR EXTERNAL THREADS			
1/8-28	0.215	0.550	0.017	0.250	2.50	4	TM215-28BSPT	TM215-28BSPT-A	100001	100007
1/4, 3/8-19	0.335	0.650	0.025	0.375	3.50	4	TM335-19BSPT	TM335-19BSPT-A	100013	100019
1/2, 3/4-14	0.430	1.100	0.035	0.500	3.50	4	TM430-14BSPT	TM430-14BSPT-A	100025	100031
1 to 6-11	0.550	1.127	0.045	0.625	3.50	5	TM550-11BSPT	TM550-11BSPT-A	100037	100043

[Go to Thread Mill Overview](#)

THREAD MILLS
BRITISH

SINGLE POINT

INDEXABLE TOOLS

PORT - CAVITY

SPECIALTY

METRIC THREAD MILLS

SINGLE PROFILE (SPTM) - SOLID CARBIDE

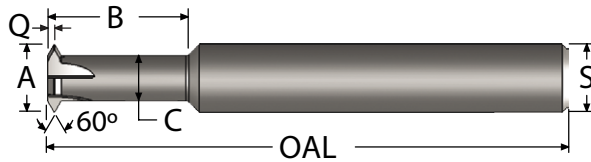

With just 19 varieties of Thread Mills, fine and coarse threads ranging from M1.2 to M30+ can be milled

Min ID THREAD*	"A" TOOL DIA.	"B" LENGTH OF CUT	"C" NECK DIA.	"Q" LENGTH	"S" SHANK DIA.	OAL	RECOM- MENDED PITCH-MM	FLUTES	ORDER #		EDP #	
									UNCOATED	AITiN+	UNCOATED	AITiN+
									INTERNAL OR EXTERNAL THREADS			
M1.2	0.032	0.060	0.018	0.005	0.1250	1.50	0.20 to 0.25	2	SPTM032	SPTM032A	120001	120067
M1.2	0.032	0.100	0.018	0.005	0.1250	1.50	0.20 to 0.25	2	SPTM032L	SPTM032LA	120004	120070
M1.6	0.040	0.090	0.022	0.006	0.1250	1.50	0.20 to 0.35	2	SPTM040	SPTM040A	120007	120073
M1.6	0.040	0.109	0.022	0.006	0.1250	1.50	0.20 to 0.35	2	SPTM040ML	SPTM040MLA	120013	120079
M1.6	0.040	0.125	0.022	0.006	0.1250	1.50	0.20 to 0.35	2	SPTM040L	SPTM040LA	120010	120076
M1.8	0.050	0.100	0.028	0.007	0.1250	1.50	0.30 to 0.40	3	SPTM050	SPTM050A	120016	120082
M1.8	0.050	0.125	0.028	0.007	0.1250	1.50	0.30 to 0.40	3	SPTM050ML	SPTM050MLA	120022	120088
M1.8	0.050	0.150	0.028	0.007	0.1250	1.50	0.30 to 0.40	3	SPTM050L	SPTM050LA	120019	120085
M1.8	0.050	0.210	0.028	0.007	0.1250	1.50	0.30 to 0.40	3	SPTM050XL	SPTM050XLA	120020	120086
M2.0	0.059	0.125	0.034	0.008	0.1250	1.50	0.30 to 0.45	3	SPTM059	SPTM059A	120025	120091
M2.0	0.059	0.165	0.034	0.008	0.1250	1.50	0.30 to 0.45	3	SPTM059ML	SPTM059MLA	120031	120097
M2.0	0.059	0.200	0.034	0.008	0.1250	1.50	0.30 to 0.45	3	SPTM059L	SPTM059LA	120028	120094
M2.0	0.059	0.250	0.034	0.008	0.1250	1.50	0.30 to 0.45	3	SPTM059XL	SPTM059XLA	120029	120095
M2.0	0.060	0.125	0.034	0.009	0.1875	2.00	0.30 to 0.45	3	SPTM060	SPTM060A	120100	120214
M2.0	0.060	0.165	0.034	0.009	0.1875	2.00	0.30 to 0.45	3	SPTM060ML	SPTM060MLA	120106	120220
M2.0	0.060	0.200	0.034	0.009	0.1875	2.00	0.30 to 0.45	3	SPTM060L	SPTM060LA	120103	120217
M2.5	0.072	0.150	0.040	0.010	0.1875	2.00	0.35 to 0.50	3	SPTM072	SPTM072A	120109	120223
M2.5	0.072	0.250	0.040	0.010	0.1875	2.00	0.35 to 0.50	3	SPTM072L	SPTM072LA	120112	120226
M2.5	0.072	0.300	0.040	0.010	0.1875	2.00	0.35 to 0.50	3	SPTM072XL	SPTM072XLA	120113	120227
M3.0	0.080	0.190	0.045	0.011	0.1875	2.00	0.40 to 0.60	3	SPTM080	SPTM080A	120115	120229
M3.0	0.080	0.250	0.045	0.011	0.1875	2.00	0.40 to 0.60	3	SPTM080ML	SPTM080MLA	120121	120235
M3.0	0.080	0.300	0.045	0.011	0.1875	2.00	0.40 to 0.60	3	SPTM080L	SPTM080LA	120118	120232
M3.0	0.080	0.375	0.045	0.011	0.1875	2.00	0.40 to 0.60	3	SPTM080XL	SPTM080XLA	120119	120233
M3.0	0.090	0.200	0.048	0.013	0.1875	2.00	0.40 to 0.60	3	SPTM090	SPTM090A	120422	120425
M3.0	0.090	0.300	0.048	0.013	0.1875	2.00	0.40 to 0.60	3	SPTM090L	SPTM090LA	120431	120434
M3.0	0.090	0.400	0.048	0.013	0.1875	2.00	0.40 to 0.60	3	SPTM090XL	SPTM090XLA	120440	120443
M3.5	0.098	0.250	0.050	0.015	0.1875	2.00	0.40 to 0.80	3	SPTM098	SPTM098A	120124	120238
M3.5	0.098	0.330	0.050	0.015	0.1875	2.00	0.40 to 0.80	3	SPTM098ML	SPTM098MLA	120130	120244
M3.5	0.098	0.400	0.050	0.015	0.1875	2.00	0.40 to 0.80	3	SPTM098L	SPTM098LA	120127	120241
M4.0	0.120	0.300	0.070	0.016	0.1875	2.00	0.45 to 0.80	3	SPTM120	SPTM120A	120133	120247
M4.0	0.120	0.400	0.070	0.016	0.1875	2.00	0.45 to 0.80	3	SPTM120ML	SPTM120MLA	120139	120253
M4.0	0.120	0.500	0.070	0.016	0.1875	2.00	0.45 to 0.80	3	SPTM120L	SPTM120LA	120136	120250
M5.0	0.138	0.400	0.075	0.020	0.1875	2.00	0.45 to 1.00	3	SPTM138	SPTM138A	120142	120256
M5.0	0.138	0.500	0.075	0.020	0.1875	2.00	0.45 to 1.00	3	SPTM138ML	SPTM138MLA	120148	120262
M5.0	0.138	0.600	0.075	0.020	0.1875	2.00	0.45 to 1.00	3	SPTM138L	SPTM138LA	120145	120259
M6.0	0.160	0.400	0.080	0.025	0.1875	2.00	0.50 to 1.25	3	SPTM160	SPTM160A	120151	120265
M6.0	0.160	0.650	0.080	0.025	0.1875	2.00	0.50 to 1.25	3	SPTM160L	SPTM160LA	120154	120268

*Single profile thread mills can cut any larger size internal thread within the recommended pitch.

[Go to Thread Mill Overview](#)

METRIC THREAD MILLS

SINGLE PROFILE (SPTM) - SOLID CARBIDE

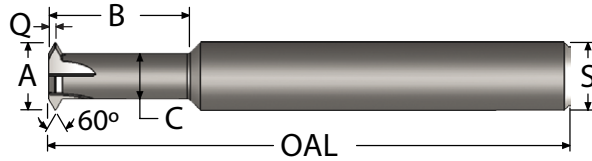

- Solid carbide provides maximum tool rigidity
- Long reach tools are available from stock
- ALTiN+ coating extends tool life

Min ID THREAD*	"A" TOOL DIA.	"B" LENGTH OF CUT	"C" NECK DIA.	"Q" LENGTH	"S" SHANK DIA.	OAL	RECOM- MENDED PITCH-MM	FLUTES	ORDER #		EDP #	
									UNCOATED	ALTiN+	UNCOATED	ALTiN+
									INTERNAL OR EXTERNAL THREADS			
M7.0	0.182	0.400	0.104	0.025	0.2500	2.50	0.50 to 1.25	4	SPTM182	SPTM182A	120271	120301
M7.0	0.182	0.530	0.104	0.025	0.2500	2.50	0.50 to 1.25	4	SPTM182ML	SPTM182MLA	120277	120307
M7.0	0.182	0.650	0.104	0.025	0.2500	2.50	0.50 to 1.25	4	SPTM182L	SPTM182LA	120274	120304
M7.0	0.182	0.800	0.104	0.025	0.2500	2.50	0.50 to 1.25	4	SPTM182XL	SPTM182XLA	120275	120305
M8.0	0.240	0.500	0.153	0.028	0.2500	2.50	0.50 to 1.50	4	SPTM240	SPTM240A	120280	120310
M8.0	0.240	0.800	0.153	0.028	0.2500	2.50	0.50 to 1.50	4	SPTM240L	SPTM240LA	120283	120313
M8.0	0.240	1.100	0.153	0.028	0.2500	2.50	0.50 to 1.50	4	SPTM240XL	SPTM240XLA	120284	120314
M10	0.290	0.600	0.192	0.031	0.3750	3.00	0.75 to 1.75	4	SPTM290	SPTM290A	120316	120340
M10	0.290	1.000	0.192	0.031	0.3750	3.00	0.75 to 1.75	4	SPTM290L	SPTM290LA	120319	120343
M10	0.290	1.400	0.192	0.031	0.3750	3.00	0.75 to 1.75	4	SPTM290XL	SPTM290XLA	120320	120344
M11	0.332	0.700	0.220	0.035	0.3750	3.00	0.80 to 2.00	4	SPTM332	SPTM332A	120450	120453
M11	0.332	1.100	0.220	0.035	0.3750	3.00	0.80 to 2.00	4	SPTM332L	SPTM332LA	120459	120462
M11	0.332	1.500	0.220	0.035	0.3750	3.00	0.80 to 2.00	4	SPTM332XL	SPTM332XLA	120468	120471
M12	0.372	0.850	0.240	0.041	0.3750	3.00	0.80 to 2.00	4	SPTM372	SPTM372A	120322	120346
M12	0.372	1.250	0.240	0.041	0.3750	3.00	0.80 to 2.00	4	SPTM372L	SPTM372LA	120325	120349
M12	0.372	1.750	0.240	0.041	0.3750	4.00	0.80 to 2.00	4	SPTM372XL	SPTM372XLA	120326	120350
M16	0.488	0.850	0.340	0.046	0.5000	3.50	0.80 to 2.50	5	SPTM488	SPTM488A	120352	120364
M16	0.488	1.350	0.340	0.046	0.5000	3.50	0.80 to 2.50	5	SPTM488L	SPTM488LA	120355	120367
M16	0.488	2.000	0.340	0.046	0.5000	4.00	0.80 to 2.50	5	SPTM488XL	SPTM488XLA	120356	120368
M20	0.595	1.250	0.430	0.051	0.6250	4.00	1.00 to 2.50	6	SPTM595	SPTM595A	120370	120382
M20	0.595	2.000	0.430	0.051	0.6250	4.00	1.00 to 2.50	6	SPTM595L	SPTM595LA	120373	120385
M20	0.595	2.750	0.430	0.051	0.6250	5.00	1.00 to 2.50	6	SPTM595XL	SPTM595XLA	120374	120386
M24	0.695	1.500	0.490	0.063	0.7500	5.00	1.00 to 3.00	6	SPTM695	SPTM695A	120388	120412
M24	0.695	2.500	0.490	0.063	0.7500	5.00	1.00 to 3.00	6	SPTM695L	SPTM695LA	120391	120415
M24	0.695	3.250	0.490	0.063	0.7500	6.00	1.00 to 3.00	6	SPTM695XL	SPTM695XLA	120392	120416
M30	0.745	1.500	0.400	0.107	0.7500	5.00	3.00 to 6.00	6	SPTM745	SPTM745A	120394	120418
M30	0.745	2.500	0.400	0.107	0.7500	5.00	3.00 to 6.00	6	SPTM745L	SPTM745LA	120397	120421
M30	0.745	3.250	0.400	0.107	0.7500	6.00	3.00 to 6.00	6	SPTM745XL	SPTM745XLA	120398	120423

*Single profile thread mills can cut any larger size internal thread within the recommended pitch.

[Go to Thread Mill Overview](#)

THREAD MILLS
METRIC

SINGLE POINT

INDEXABLE TOOLS

PORT - CAVITY

SPECIALTY

METRIC THREAD MILLS

LONG REACH (TMLR) - SOLID CARBIDE

FULL PROFILE

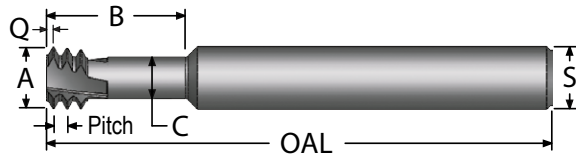

- Small thread milling is made easy with TMLR tools
- Minimal cutting pressure
- Thread sizes starting from M1.4-.3mm

MIN ID THREAD /PITCH*	"A" TOOL DIA.	"B" LENGTH OF CUT	"C" NECK DIA.	"Q" LENGTH	"S" SHANK DIA.	OAL	FLUTES	ORDER #		EDP #	
								UNCOATED	ALTiN+	UNCOATED	ALTiN+
								INTERNAL THREADS ONLY			
M1.4-.3	0.039	0.115	0.021	0.006	0.125	1.50	3	TMLR1.4-.3MM	TMLR1.4-.3MMA	110001	110019
M1.4-.3	0.039	0.150	0.021	0.006	0.125	1.50	3	TMLR1.4-.3MMEL	TMLR1.4-.3MMELA	110004	110022
M1.6-.35	0.045	0.135	0.023	0.007	0.125	1.50	3	TMLR1.6-.35MM	TMLR1.6-.35MMA	110007	110025
M1.6-.35	0.045	0.180	0.023	0.007	0.125	1.50	3	TMLR1.6-.35MMEL	TMLR1.6-.35MMELA	110010	110028
M2-.4	0.056	0.150	0.030	0.008	0.125	1.50	3	TMLR2-.4MM	TMLR2-.4MMA	110013	110031
M2-.4	0.056	0.200	0.030	0.008	0.125	1.50	3	TMLR2-.4MMEL	TMLR2-.4MMELA	110016	110034
M2-.4	0.056	0.150	0.030	0.008	0.250	2.50	3	TMLR2-.4MM	TMLR2-.4MMA	110037	110097
M2-.4	0.056	0.200	0.030	0.008	0.250	2.50	3	TMLR2-.4MMEL	TMLR2-.4MMELA	110040	110100
M2.5-.45	0.073	0.190	0.046	0.009	0.250	2.50	3	TMLR2.5-.45MM	TMLR2.5-.45MMA	110043	110103
M2.5-.45	0.073	0.250	0.046	0.009	0.250	2.50	3	TMLR2.5-.45MMEL	TMLR2.5-.45MMELA	110046	110106
M3-.5	0.090	0.225	0.059	0.010	0.250	2.50	3	TMLR3-.5MM	TMLR3-.5MMA	110049	110109
M3-.5	0.090	0.300	0.059	0.010	0.250	2.50	3	TMLR3-.5MMEL	TMLR3-.5MMELA	110052	110112
M4-.5	0.120	0.300	0.089	0.010	0.250	2.50	3	TMLR4-.5MM	TMLR4-.5MMA	110055	110115
M4-.5	0.120	0.500	0.089	0.010	0.250	2.50	3	TMLR4-.5MMEL	TMLR4-.5MMELA	110058	110118
M4-.7	0.120	0.300	0.079	0.014	0.250	2.50	3	TMLR4-.7MM	TMLR4-.7MMA	110061	110121
M4-.7	0.120	0.500	0.079	0.014	0.250	2.50	3	TMLR4-.7MMEL	TMLR4-.7MMELA	110064	110124
M5-.8	0.150	0.400	0.103	0.016	0.250	2.50	3	TMLR5-.8MM	TMLR5-.8MMA	110067	110127
M5-.8	0.150	0.600	0.103	0.016	0.250	2.50	3	TMLR5-.8MMEL	TMLR5-.8MMELA	110070	110130
M6-1	0.180	0.500	0.120	0.020	0.250	2.50	3	TMLR6-1MM	TMLR6-1MMA	110073	110133
M6-1	0.180	0.700	0.120	0.020	0.250	2.50	3	TMLR6-1MMEL	TMLR6-1MMELA	110076	110136
M8-.75	0.234	0.600	0.190	0.015	0.250	2.50	3	TMLR8-.75MM	TMLR8-.75MMA	110079	110139
M8-.75	0.234	0.850	0.190	0.015	0.250	2.50	3	TMLR8-.75MMEL	TMLR8-.75MMELA	110082	110142
M8-1	0.234	0.600	0.175	0.020	0.250	2.50	3	TMLR8-1MM	TMLR8-1MMA	110091	110151
M8-1	0.234	0.850	0.175	0.020	0.250	2.50	3	TMLR8-1MMEL	TMLR8-1MMELA	110094	110154
M8-1.25	0.234	0.600	0.162	0.025	0.250	2.50	3	TMLR8-1.25MM	TMLR8-1.25MMA	110085	110145
M8-1.25	0.234	0.850	0.162	0.025	0.250	2.50	3	TMLR8-1.25MMEL	TMLR8-1.25MMELA	110088	110148
M10-1	0.310	0.750	0.250	0.020	0.375	3.50	3	TMLR10-1MM	TMLR10-1MMA	110163	110187
M10-1	0.310	1.000	0.250	0.020	0.375	3.50	3	TMLR10-1MMEL	TMLR10-1MMELA	110166	110190
M10-1.5	0.310	0.750	0.223	0.030	0.375	3.50	3	TMLR10-1.5MM	TMLR10-1.5MMA	110157	110181
M10-1.5	0.310	1.000	0.223	0.030	0.375	3.50	3	TMLR10-1.5MMEL	TMLR10-1.5MMELA	110160	110184
M12-1	0.370	0.800	0.310	0.020	0.375	3.50	3	TMLR12-1MM	TMLR12-1MMA	110175	110199
M12-1	0.370	1.200	0.310	0.020	0.375	3.50	3	TMLR12-1MMEL	TMLR12-1MMELA	110178	110202
M12-1.25	0.370	0.800	0.295	0.025	0.375	3.50	3	TMLR12-1.25MM	TMLR12-1.25MMA	110169	110193
M12-1.25	0.370	1.200	0.295	0.025	0.375	3.50	3	TMLR12-1.25MMEL	TMLR12-1.25MMELA	110172	110196
M14-1.5	0.450	1.200	0.360	0.030	0.500	4.00	4	TMLR14-1.5MM	TMLR14-1.5MMA	110205	110217
M14-1.5	0.450	1.650	0.360	0.030	0.500	4.00	4	TMLR14-1.5MMEL	TMLR14-1.5MMELA	110208	110220
M14-2	0.450	1.200	0.330	0.039	0.500	4.00	4	TMLR14-2MM	TMLR14-2MMA	110211	110223
M14-2	0.450	1.650	0.330	0.039	0.500	4.00	4	TMLR14-2MMEL	TMLR14-2MMELA	110214	110226

*Thread mills can cut any larger size internal thread of the same pitch

[Go to Thread Mill Overview](#)

THREAD MILLS - METRIC STRAIGHT FLUTE - CARBIDE FULL PROFILE

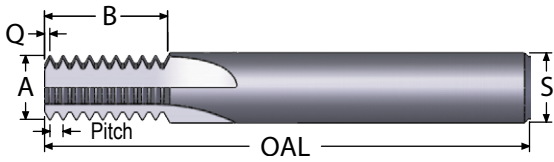

- Short length-of-cut for ideal length-to-diameter ratio
- Polished flute face for optimum performance
- Made with premium submicron grade carbide
- Internal crest cutting design for strongest possible tool

MIN ID THREAD/ PITCH*	"A" TOOL DIA.	"B" LENGTH OF CUT	"Q" LENGTH	"S" SHANK DIA.	OAL	FLUTES	ORDER #		EDP #	
							UNCOATED	ALTiN+	UNCOATED	ALTiN+
INTERNAL THREADS ONLY										
M3-.5	0.090	0.264	0.009	0.250	2.50	3	TM3-.5MM	TM3-.5MM-A	100104	100188
M3-.5	0.090	0.185	0.009	0.250	2.50	3	TM3-.5MM-S	TM3-.5MM-SA	100554	100620
M3.5-.6	0.090	0.269	0.011	0.250	2.50	3	TM3.5-.6MM	TM3.5-.6MM-A	100101	100185
M3.5-.6	0.090	0.175	0.011	0.250	2.50	3	TM3.5-.6MM-S	TM3.5-.6MM-SA	100551	100617
M4-.5	0.110	0.323	0.009	0.250	2.50	3	TM4-.5MM	TM4-.5MM-A	100110	100194
M4-.5	0.110	0.224	0.009	0.250	2.50	3	TM4-.5MM-S	TM4-.5MM-SA	100560	100626
M4-.7	0.110	0.342	0.012	0.250	2.50	3	TM4-.7MM	TM4-.7MM-A	100113	100197
M4-.7	0.110	0.231	0.012	0.250	2.50	3	TM4-.7MM-S	TM4-.7MM-SA	100563	100629
M4.5-.75	0.125	0.337	0.013	0.250	2.50	3	TM4.5-.75MM	TM4.5-.75MM-A	100107	100191
M4.5-.75	0.125	0.219	0.013	0.250	2.50	3	TM4.5-.75MM-S	TM4.5-.75MM-SA	100557	100623
M5-.7	0.140	0.397	0.012	0.250	2.50	3	TM5-.7MM	TM5-.7MM-A	100116	100200
M5-.7	0.140	0.259	0.012	0.250	2.50	3	TM5-.7MM-S	TM5-.7MM-SA	100566	100632
M5-.8	0.140	0.391	0.014	0.250	2.50	3	TM5-.8MM	TM5-.8MM-A	100119	100203
M5-.8	0.140	0.265	0.014	0.250	2.50	3	TM5-.8MM-S	TM5-.8MM-SA	100569	100635
M6-.5	0.170	0.520	0.009	0.250	2.50	3	TM6-.5MM	TM6-.5MM-A	100122	100206
M6-.5	0.170	0.382	0.009	0.250	2.50	3	TM6-.5MM-S	TM6-.5MM-SA	100572	100638
M6-.75	0.170	0.543	0.013	0.250	2.50	3	TM6-.75MM	TM6-.75MM-A	100125	100209
M6-.75	0.170	0.366	0.013	0.250	2.50	3	TM6-.75MM-S	TM6-.75MM-SA	100575	100641
M6-1	0.170	0.528	0.018	0.250	2.50	3	TM6-1MM	TM6-1MM-A	100131	100215
M6-1	0.170	0.370	0.018	0.250	2.50	3	TM6-1MM-S	TM6-1MM-SA	100581	100647
M6-1.25	0.170	0.561	0.022	0.250	2.50	3	TM6-1.25MM	TM6-1.25MM-A	100128	100212
M6-1.25	0.170	0.364	0.022	0.250	2.50	3	TM6-1.25MM-S	TM6-1.25MM-SA	100578	100644
M8-.75	0.235	0.662	0.013	0.250	2.50	3	TM8-.75MM	TM8-.75MM-A	100134	100218
M8-1	0.235	0.685	0.018	0.250	2.50	3	TM8-1MM	TM8-1MM-A	100140	100224
M8-1.25	0.235	0.660	0.022	0.250	2.50	3	TM8-1.25MM	TM8-1.25MM-A	100137	100221
M10-1	0.290	0.803	0.018	0.3125	3.50	4	TM10-1MM	TM10-1MM-A	100230	100242
M10-1.5	0.290	0.792	0.027	0.3125	3.50	4	TM10-1.5MM	TM10-1.5MM-A	100227	100239
M12-1.25	0.345	0.807	0.022	0.375	3.50	4	TM12-1.25MM	TM12-1.25MM-A	100245	100263
M12-1.5	0.345	0.792	0.027	0.375	3.50	4	TM12-1.5MM	TM12-1.5MM-A	100248	100266
M12-1.75	0.345	0.787	0.031	0.375	3.50	4	TM12-1.75MM	TM12-1.75MM-A	100251	100269
M12-1	0.400	1.079	0.018	0.500	3.50	4	TM12-1MM	TM12-1MM-A	100272	100308
M14-1.25	0.450	1.103	0.022	0.500	3.50	4	TM14-1.25MM	TM14-1.25MM-A	100275	100311
M14-1.5	0.450	1.087	0.027	0.500	3.50	4	TM14-1.5MM	TM14-1.5MM-A	100278	100314
M14-1.75	0.450	1.134	0.031	0.500	3.50	4	TM14-1.75MM	TM14-1.75MM-A	100281	100317
M14-2	0.450	1.134	0.035	0.500	3.50	4	TM14-2MM	TM14-2MM-A	100284	100320
M16-2.5	0.450	1.122	0.044	0.500	3.50	4	TM16-2.5MM	TM16-2.5MM-A	100287	100323

*Thread mills can cut any larger size internal thread of the same pitch

[Go to Thread Mill Overview](#)

THREAD MILLS METRIC
SINGLE POINT
INDEXABLE TOOLS
PORT - CAVITY
SPECIALTY

METRIC THREAD MILLS

COOLANT THROUGH - SOLID CARBIDE - FULL PROFILE

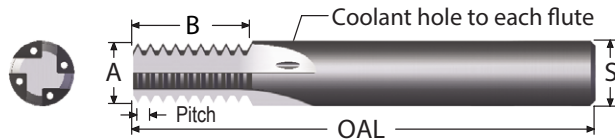

- ALTiN+ coating for higher cutting speed
- Coolant to each flute
- Made with premium submicron grade carbide
- Internal Threads Only

MIN IN THREAD/ PITCH*	"A" TOOL DIA.	"B" LENGTH OF CUT	"Q" LENGTH	"S" SHANK DIA.	OAL	FLUTE	ORDER #		EDP #	
							UNCOATED	AITiN	UNCOATED	AITiN
<i>INTERNAL THREADS ONLY</i>										
M3-.5	0.090	0.264	0.009	0.250	2.50	3	TMC3-.5MM	TMC3-.5MM-A	100401	100428
M4-.5	0.110	0.323	0.009	0.250	2.50	3	TMC4-.5MM	TMC4-.5MM-A	100407	100434
M4-.7	0.110	0.342	0.012	0.250	2.50	3	TMC4-.7MM	TMC4-.7MM-A	100410	100437
M4.5-.75	0.125	0.337	0.013	0.250	2.50	3	TMC4.5-.75MM	TMC4.5-.75MM-A	100404	100431
M5-.8	0.140	0.391	0.014	0.250	2.50	3	TMC5-.8MM	TMC5-.8MM-A	100413	100440
M6-.5	0.170	0.520	0.009	0.250	2.50	3	TMC6-.5MM	TMC6-.5MM-A	100416	100443
M6-1	0.170	0.528	0.018	0.250	2.50	3	TMC6-1MM	TMC6-1MM-A	100419	100446
M8-1	0.235	0.685	0.018	0.250	2.50	3	TMC8-1MM	TMC8-1MM-A	100425	100452
M8-1.25	0.235	0.660	0.022	0.250	2.50	3	TMC8-1.25MM	TMC8-1.25MM-A	100422	100449
M10-1	0.290	0.803	0.018	0.3125	3.50	4	TMC10-1MM	TMC10-1MM-A	100458	100464
M10-1.5	0.290	0.792	0.027	0.3125	3.50	4	TMC10-1.5MM	TMC10-1.5MM-A	100455	100461
M12-1.25	0.345	0.807	0.022	0.375	3.50	4	TMC12-1.25MM	TMC12-1.25MM-A	100467	100470
M14-1.5	0.450	1.087	0.027	0.500	3.50	4	TMC14-1.5MM	TMC14-1.5MM-A	100473	100479
M14-2	0.450	1.134	0.035	0.500	3.50	4	TMC14-2MM	TMC14-2MM-A	100476	100482

*Thread mills can cut any larger size internal thread of the same pitch

METRIC THREAD MILL

COOLANT THROUGH - CARBIDE TIPPED

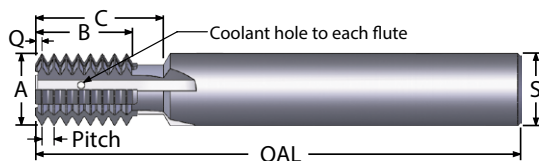

- Non-crest cutting on the internal thread allows maximum flexibility for plated and non-standard threads

MIN ID THREAD/ PITCH*	"A" TOOL DIA.	"B" LENGTH OF CUT	"C" TOOL REACH	"Q" LENGTH	"S" SHANK DIA.	OAL	FLUTES	ORDER #		EDP #	
								UNCOATED	AITiN	UNCOATED	ALTiN+
<i>INTERNAL OR EXTERNAL THREADS</i>											
M24-1.5	0.740	1.058	1.370	0.027	0.750	6.00	4	TMC24-1.5MM	TMC24-1.5MM-A	100485	100515
M24-2	0.740	1.100	1.370	0.036	0.750	6.00	4	TMC24-2MM	TMC24-2MM-A	100494	100524
M24-2.5	0.740	1.076	1.370	0.045	0.750	6.00	4	TMC24-2.5MM	TMC24-2.5MM-A	100491	100521
M24-3	0.740	1.058	1.370	0.054	0.750	6.00	4	TMC24-3MM	TMC24-3MM-A	100497	100527
M36-4	0.990	1.095	2.000	0.071	1.000	6.00	6	TMC36-4MM	TMC36-4MM-A	100530	100536

*Thread mills can cut any larger size internal thread of the same pitch

[Go to Thread Mill Overview](#)

THREAD MILL - METRIC - 15° HELICAL FLUTE - CARBIDE

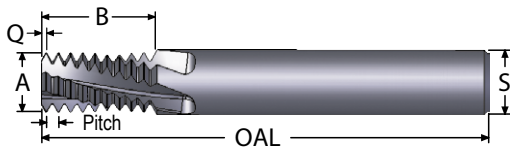

- Helical flute for reduced side cutting pressure
- ALTiN+ coating extends tool life

MIN ID THREAD / PITCH*	"A" TOOL DIA.	"B" LENGTH OF CUT	"Q" LENGTH	"S" SHANK DIA.	OAL	FLUTES	ORDER #		EDP #	
							UNCOATED	ALTiN+	UNCOATED	ALTiN+
							INTERNAL THREADS ONLY			
M5.0-.8	0.118	0.328	0.014	6mm	58mm	3	TMI5.0-0.80-H	TMI5.0-0.80-HA	100704	100722
M6.0-1	0.169	0.488	0.018	6mm	58mm	3	TMI6.0-1.00-H	TMI6.0-1.00-HA	100707	100725
M8.0-.75	0.234	0.632	0.013	6mm	58mm	3	TMI8.0-0.75-H	TMI8.0-0.75-HA	100710	100728
M8.0-1	0.234	0.646	0.018	6mm	58mm	3	TMI8.0-1.00-H	TMI8.0-1.00-HA	100713	100731
M8.0-1.25	0.234	0.659	0.022	6mm	58mm	3	TMI8.0-1.25-H	TMI8.0-1.25-HA	100716	100734
M10-1.5	0.300	0.790	0.027	8mm	75mm	4	TMI10-1.50-H	TMI10-1.50-HA	103153	103156
M12-1	0.360	0.881	0.018	10mm	100mm	4	TMI12-1.00-H	TMI12-1.00-HA	103117	103126
M12-1.75	0.360	0.923	0.031	10mm	100mm	4	TMI12-1.75-H	TMI12-1.75-HA	103120	103129
M14-1.5	0.370	0.909	0.027	10mm	100mm	4	TMI14-1.50-H	TMI14-1.50-HA	103123	103132
M16-2	0.470	1.290	0.035	12mm	100mm	4	TMI16-2.00-H	TMI16-2.00-HA	103135	103144
M18-1.5	0.470	1.263	0.027	12mm	100mm	4	TMI18-1.50-H	TMI18-1.50-HA	103138	103147
M20-2.5	0.470	1.318	0.044	12mm	100mm	4	TMI20-2.50-H	TMI20-2.50-HA	103141	103150

*Thread mills can cut any larger size internal thread of the same pitch

THREAD MILL - METRIC - 30° HELICAL FLUTE - CARBIDE

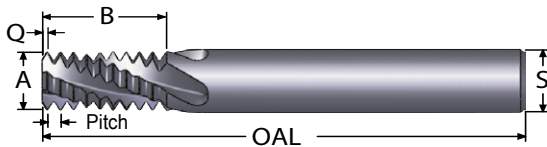

- Optional short length-of-cut for ideal length-to-diameter ratio
- Internal and external threads

MIN ID THREAD / PITCH*	"A" TOOL DIA.	"B" LENGTH OF CUT	"Q" LENGTH	"S" SHANK DIA.	OAL	FLUTES	ORDER #		EDP #	
							UNCOATED	ALTiN+	UNCOATED	ALTiN+
							INTERNAL OR EXTERNAL THREADS			
M6-.5	0.170	0.520	0.009	0.250	2.50	3	TM6-.5MM-H	TM6-.5MM-HA	100751	100817
M6-.5	0.170	0.382	0.009	0.250	2.50	3	TM6-.5MM-SH	TM6-.5MM-SHA	100754	100820
M6-.75	0.170	0.543	0.013	0.250	2.50	3	TM6-.75MM-H	TM6-.75MM-HA	100757	100823
M6-.75	0.170	0.366	0.013	0.250	2.50	3	TM6-.75MM-SH	TM6-.75MM-SHA	100760	100826
M6-1	0.170	0.528	0.018	0.250	2.50	3	TM6-1MM-H	TM6-1MM-HA	100769	100835
M6-1	0.170	0.370	0.018	0.250	2.50	3	TM6-1MM-SH	TM6-1MM-SHA	100772	100838
M6-1.25	0.170	0.561	0.022	0.250	2.50	3	TM6-1.25MM-H	TM6-1.25MM-HA	100763	100829
M6-1.25	0.170	0.364	0.022	0.250	2.50	3	TM6-1.25MM-SH	TM6-1.25MM-SHA	100766	100832
M8-.75	0.235	0.662	0.013	0.250	2.50	3	TM8-.75MM-H	TM8-.75MM-HA	100775	100841
M8-1	0.235	0.685	0.018	0.250	2.50	3	TM8-1MM-H	TM8-1MM-HA	100781	100847
M8-1.25	0.235	0.660	0.022	0.250	2.50	3	TM8-1.25MM-H	TM8-1.25MM-HA	100778	100844
M10-1	0.290	0.803	0.018	0.3125	3.50	4	TM10-1MM-H	TM10-1MM-HA	100853	100865
M10-1.5	0.290	0.792	0.027	0.3125	3.50	4	TM10-1.5MM-H	TM10-1.5MM-HA	100850	100862
M12-1.25	0.345	0.807	0.022	0.375	3.50	4	TM12-1.25MM-H	TM12-1.25MM-HA	100868	100886
M12-1.5	0.345	0.792	0.027	0.375	3.50	4	TM12-1.5MM-H	TM12-1.5MM-HA	100871	100889
M12-1.75	0.345	0.787	0.031	0.375	3.50	4	TM12-1.75MM-H	TM12-1.75MM-HA	100874	100892
M12-1	0.400	1.079	0.018	0.500	3.50	4	TM12-1MM-H	TM12-1MM-HA	100895	100931
M14-1.25	0.450	1.103	0.022	0.500	3.50	4	TM14-1.25MM-H	TM14-1.25MM-HA	100898	100934
M14-1.5	0.450	1.087	0.027	0.500	3.50	4	TM14-1.5MM-H	TM14-1.5MM-HA	100901	100937
M14-1.75	0.450	1.134	0.031	0.500	3.50	4	TM14-1.75MM-H	TM14-1.75MM-HA	100904	100940
M14-2	0.450	1.134	0.035	0.500	3.50	4	TM14-2MM-H	TM14-2MM-HA	100907	100943
M16-2.5	0.450	1.122	0.044	0.500	3.50	4	TM16-2.5MM-H	TM16-2.5MM-HA	100910	100946

*Thread mills can cut any larger size internal thread of the same pitch

[Go to Thread Mill Overview](#)

THREAD MILLS METRIC
 SINGLE POINT
 INDEXABLE TOOLS
 PORT - CAVITY
 SPECIALTY

STUB ACME - INTERNAL AND EXTERNAL SOLID CARBIDE SINGLE PROFILE THREAD MILLS

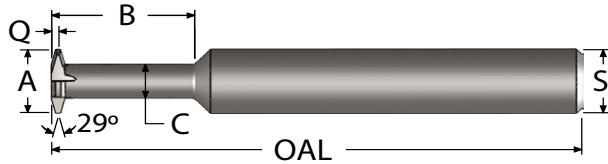

- Solid carbide for maximum tool rigidity
- ALTiN+ coating for increased performance
- Single start threads only
- For 2G and 3G fit-class threads

INTERNAL ONLY

* THREAD/ PITCH	"A" CUTTER DIA.	"B" LENGTH OF CUT	"C" NECK DIA.	"Q" LENGTH	"S" SHANK DIA.	OAL	FLUTES	ORDER #		EDP #	
								UNCOATED	ALTiN+	UNCOATED	ALTiN+
								INTERNAL THREADS ONLY			
1/4-16	0.170	0.350	0.080	0.022	0.250	2.50	4	SPTM170SA-16	SPTM170SA-16A	120501	120525
1/4-16	0.170	0.500	0.080	0.022	0.250	2.50	4	SPTM170SA-16L	SPTM170SA-16LA	120504	120528
5/16-14	0.200	0.500	0.105	0.024	0.250	2.50	4	SPTM200SA-14	SPTM200SA-14A	120507	120531
5/16-14	0.200	0.750	0.105	0.024	0.250	2.50	4	SPTM200SA-14L	SPTM200SA-14LA	120510	120534
3/8-12, 7/16-12	0.235	0.600	0.130	0.028	0.250	2.50	4	SPTM235SA-12	SPTM235SA-12A	120513	120537
3/8-12, 7/16-12	0.235	0.900	0.130	0.028	0.250	2.50	4	SPTM235SA-12L	SPTM235SA-12LA	120516	120540
1/2-10	0.320	0.750	0.170	0.036	0.375	3.00	4	SPTM320SA-10	SPTM320SA-10A	120549	120558
1/2-10	0.320	1.200	0.170	0.036	0.375	3.00	4	SPTM320SA-10L	SPTM320SA-10LA	120552	120561
5/8-8	0.400	0.800	0.230	0.043	0.500	3.50	4	SPTM400SA-8	SPTM400SA-8A	120567	120585
5/8-8	0.400	1.300	0.230	0.043	0.500	3.50	4	SPTM400SA-8L	SPTM400SA-8LA	120570	120588
3/4-6, 7/8-6	0.490	0.800	0.260	0.058	0.500	3.50	4	SPTM490SA-6	SPTM490SA-6A	120573	120591
3/4-6, 7/8-6	0.490	1.300	0.260	0.058	0.500	3.50	4	SPTM490SA-6L	SPTM490SA-6LA	120576	120594
1-5 to 1¼-5	0.620	1.250	0.350	0.071	0.625	4.00	5	SPTM620SA-5	SPTM620SA-5A	120603	120612
1-5 to 1¼-5	0.620	1.750	0.350	0.071	0.625	4.00	5	SPTM620SA-5L	SPTM620SA-5LA	120606	120615
1¾-4 to 1¼-4	0.745	1.500	0.425	0.088	0.750	5.00	5	SPTM745SA-4	SPTM745SA-4A	120621	120633
1¾-4 to 1¼-4	0.745	2.500	0.425	0.088	0.750	5.00	5	SPTM745SA-4L	SPTM745SA-4LA	120627	120639

* Internal Stub Acme thread mills will only cut the thread size listed.
For other thread sizes, please call for availability.

EXTERNAL ONLY

THREAD/ PITCH	"A" TOOL DIA.	"B" LENGTH OF CUT	"C" NECK DIA.	"Q" LENGTH	"S" SHANK DIA.	OAL	FLUTES	ORDER #		EDP #	
								UNCOATED	ALTiN+	UNCOATED	ALTiN+
								EXTERNAL THREADS ONLY			
-16	0.240	0.750	0.145	0.024	0.250	2.50	4	SPTM240SA-16EX	SPTM240SA-16EXA	120522	120546
-14	0.240	0.750	0.145	0.026	0.250	2.50	4	SPTM240SA-14EX	SPTM240SA-14EXA	120519	120543
-12	0.370	1.375	0.260	0.031	0.375	3.00	4	SPTM370SA-12EX	SPTM370SA-12EXA	120555	120564
-10	0.495	1.750	0.345	0.038	0.500	3.50	4	SPTM495SA-10EX	SPTM495SA-10EXA	120579	120597
-8	0.495	1.750	0.325	0.046	0.500	3.50	4	SPTM495SA-8EX	SPTM495SA-8EXA	120582	120600
-6	0.620	2.000	0.390	0.062	0.625	4.00	5	SPTM620SA-6EX	SPTM620SA-6EXA	120609	120618
-5	0.745	2.250	0.475	0.074	0.750	5.00	5	SPTM745SA-5EX	SPTM745SA-5EXA	120630	120642
-4	0.745	2.250	0.425	0.091	0.750	5.00	5	SPTM745SA-4EX	SPTM745SA-4EXA	120624	120636

Go to Thread Mill Overview

ACME - INTERNAL AND EXTERNAL SOLID CARBIDE SINGLE PROFILE THREAD MILLS

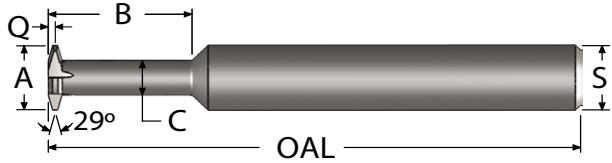

- Solid carbide for maximum tool rigidity
- ALTiN+ coating for increased performance
- Single start threads only
- For 2G and 3G fit-class threads

INTERNAL ONLY

* THREAD/ PITCH	"A" CUTTER DIA.	"B" LENGTH OF CUT	"C" NECK DIA.	"Q" LENGTH	"S" SHANK DIA.	OAL	FLUTES	ORDER #		EDP #	
								UNCOATED	ALTiN+	UNCOATED	ALTiN+
<i>INTERNAL THREADS ONLY</i>											
1/4-16	0.170	0.350	0.080	0.020	0.250	2.50	4	SPTM170FA-16	SPTM170FA-16A	120701	120725
1/4-16	0.170	0.500	0.080	0.020	0.250	2.50	4	SPTM170FA-16L	SPTM170FA-16LA	120704	120728
5/16-14	0.200	0.500	0.105	0.023	0.250	2.50	4	SPTM200FA-14	SPTM200FA-14A	120707	120731
5/16-14	0.200	0.750	0.105	0.023	0.250	2.50	4	SPTM200FA-14L	SPTM200FA-14LA	120710	120734
3/8-12, 7/16-12	0.235	0.600	0.130	0.026	0.250	2.50	4	SPTM235FA-12	SPTM235FA-12A	120713	120737
3/8-12, 7/16-12	0.235	0.900	0.130	0.026	0.250	2.50	4	SPTM235FA-12L	SPTM235FA-12LA	120716	120740
1/2-10	0.320	0.750	0.170	0.033	0.375	3.00	4	SPTM320FA-10	SPTM320FA-10A	120749	120758
1/2-10	0.320	1.200	0.170	0.033	0.375	3.00	4	SPTM320FA-10L	SPTM320FA-10LA	120752	120761
5/8-8	0.400	0.800	0.230	0.039	0.500	3.50	4	SPTM400FA-8	SPTM400FA-8A	120767	120785
5/8-8	0.400	1.300	0.230	0.039	0.500	3.50	4	SPTM400FA-8L	SPTM400FA-8LA	120770	120788
3/4-6, 7/8-6	0.490	0.800	0.260	0.054	0.500	3.50	4	SPTM490FA-6	SPTM490FA-6A	120773	120791
3/4-6, 7/8-6	0.490	1.300	0.260	0.054	0.500	3.50	4	SPTM490FA-6L	SPTM490FA-6LA	120776	120794
1-5 to 1¼-5	0.620	1.250	0.350	0.066	0.625	4.00	5	SPTM620FA-5	SPTM620FA-5A	120803	120812
1-5 to 1¼-5	0.620	1.750	0.350	0.066	0.625	4.00	5	SPTM620FA-5L	SPTM620FA-5LA	120806	120815
1¾-4 to 1¾-4	0.745	1.500	0.425	0.082	0.750	5.00	5	SPTM745FA-4	SPTM745FA-4A	120821	120833
1¾-4 to 1¾-4	0.745	2.500	0.425	0.082	0.750	5.00	5	SPTM745FA-4L	SPTM745FA-4LA	120827	120839

* Internal Acme thread mills will only cut the thread size listed.
For other thread sizes, please call for availability.

EXTERNAL ONLY

THREAD/ PITCH	"A" TOOL DIA.	"B" LENGTH OF CUT	"C" NECK DIA.	"Q" LENGTH	"S" SHANK DIA.	OAL	FLUTES	ORDER #		EDP #	
								UNCOATED	ALTiN+	UNCOATED	ALTiN+
<i>EXTERNAL THREADS ONLY</i>											
-16	0.240	0.750	0.145	0.023	0.250	2.50	4	SPTM240FA-16EX	SPTM240FA-16EXA	120722	120746
-14	0.240	0.750	0.145	0.024	0.250	2.50	4	SPTM240FA-14EX	SPTM240FA-14EXA	120719	120743
-12	0.370	1.375	0.260	0.028	0.375	3.00	4	SPTM370FA-12EX	SPTM370FA-12EXA	120755	120764
-10	0.495	1.750	0.345	0.036	0.500	3.50	4	SPTM495FA-10EX	SPTM495FA-10EXA	120779	120797
-8	0.495	1.750	0.325	0.043	0.500	3.50	4	SPTM495FA-8EX	SPTM495FA-8EXA	120782	120800
-6	0.620	2.000	0.390	0.058	0.625	4.00	5	SPTM620FA-6EX	SPTM620FA-6EXA	120809	120818
-5	0.745	2.250	0.475	0.069	0.750	5.00	5	SPTM745FA-5EX	SPTM745FA-5EXA	120830	120842
-4	0.745	2.250	0.425	0.085	0.750	5.00	5	SPTM745FA-4EX	SPTM745FA-4EXA	120824	120836

[Go to Thread Mill Overview](#)

THREAD MILLS METRIC

SINGLE POINT

INDEXABLE TOOLS

PORT - CAVITY

SPECIALTY

THREAD MILL FEED AND SPEED CHART

MATERIAL	HB/Rc	SPEED SFM* UNCOATED	SPEED SFM ALTiN+	FEED (INCHES PER TOOTH)					
				TOOL DIAMETER					
				.032 - .056	.059 - .090	.100 - .190	.200 - .350	.370 - .595	.600+
CAST IRON	160 HB	100-220	200-425	.0004-.001	.0004-.0008	.0004-.0014	.0004-.002	.0004-.0035	.0004-.006
CARBON STEEL	18 Rc	100-200	190-425	.0003-.001	.0003-.0008	.0003-.0014	.0003-.002	.0003-.005	.0003-.006
ALLOY STEEL	20 Rc	80-200	200-375	.0003-.001 2 Passes	.0003-.0008 3 Passes	.0003-.0014	.0003-.0024	.0003-.005	.0003-.006
TOOL STEEL	20 Rc	80-175	175-250	.0003-.0004 2 Passes	.0003-0.0005 3 Passes	.0003-.0005	.0003-.0009	.0003-.0026	.0003-.004
300 STAINLESS STEEL	150 HB	90-120	120-255	.0003-.0005 2 Passes	.0003-0.0006 3 Passes	.0003-.0007	.0003-.002	.0003-.0035	.0003-.0045
400 STAINLESS STEEL	195 HB	90-150	140-375	.0003-.0005 2 Passes	.0003-.0006 3 Passes	.0003-.0007	.0003-.002	.0003-.0026	.0003-.0045
HIGH TEMP ALLOY (Ni & Co BASE)	20 Rc	50-125	100-125	.0003-.0004 3 Passes	.0003-.00045 3 Passes	.0003-.0005 2 Passes	.0003-.0009	.0003-.0026	.0003-.004
TITANIUM	25 Rc	50-130	100-170	.0003-.0004 3 Passes	.0003-.00045 3 Passes	.0003-.001 2 Passes	.0003-.0009	.0003-.0015	.0003-.003
HEAT TREATED ALLOYS (38-45Rc)	40 Rc	50-90	90-150	.0003-.0004 3 Passes	.0003-.00045 3 Passes	.0003-.0005 2 Passes	.0003-.0008	.0003-.001	.0003-.0025
ALUMINUM	100 HB	100-800	100-1200	.0005-.0015	.0005-.002	.0005-.0025	.0005-.003	.0005-.006	.0005-.009
BRASS, ZINC	80 HB	200-350	200-750	.0005-.0015	.0005-.002	.0005-.0025	.0005-.003	.0005-.006	.0005-.009

*SFM = Surface Feet per Minute

Parameters are a starting point based on machinability rating at hardness listed. Check machinability rating of the material to be machined and adjust accordingly.

Looking for the Thread Mill Locator Chart? It is now online.
Visit www.sct-usa.com and click on resources.

**FREE THREAD MILL CODE GENERATOR FOR SCT THREAD MILLS
AVAILABLE NOW AT WWW.SCT-USA.COM**



- EASY TO USE WITH SIMPLE INPUT FIELDS
- QUICKLY GENERATES CODE TO SAVE TIME
- FANUC AND FANUC COMPATIBLE CONTROLS
- GENERATES CODES FOR ID AND OD THREADS

THREAD MILL FEED AND SPEED APPLICATION



It may be necessary to use more radial depth passes than shown on the chart (p.31) when cutting an unfavorable length-to-diameter ratio, coarse pitches, or hard materials. When cutting a thread with two passes, cut approximately **65% of the thread on the first pass and 35 percent on the finish pass.** For three passes, use a **50/30/20** ratio. For four passes, use a **40/27/20/13** ratio. The idea is to equalize the side cutting pressure.

Thread mills can sometimes be used to cut multiple start threads. Call engineering for assistance.

Thread mills can be cut off for shorter thread depths or necked back for deeper thread depths. Call for price and delivery.

In order to apply the Feed and Speed chart appropriately, it is necessary to understand that machining centers will apply the feed rate at the centerline of the spindle. It is correct to use a normal calculation and the following Feed & Speed Chart when cutting in a straight line; however, it is incorrect when cutting an internal thread. Therefore, the feed rate must be recalculated.

The following is an example of how to apply the feed rate correctly:

The tool is a TM290-24A cutting a 3/8-24 thread in stainless steel.

The outside diameter of the tool is 0.290.

The surface foot per minute (SFM) is 150.

The chip per tooth is 0.001. The tool has four flutes.

The revolutions per minute (RPM) equal the SFM x 3.82 divided by the outside diameter of the tool.

In this example: **$(150 \times 3.82) / 0.290$** , which equals 1975 RPM.

The RPM x feed (chip per tooth) x the number of flutes equals the Non-Adjusted Feed Rate or NAFR.

In this example: **$1975 \times 0.001 \times 4 = 7.9$ NAFR**

The major diameter of the thread is 0.375. We will call this D.

The outside diameter of the tool is 0.290. We will call this d.

We will call the Adjusted Feed Rate the AFR.

The formula for the AFR for internal interpolation is **$AFR = NAFR \times (D-d) \div D$**

In this example: **$AFR = 7.9 \times (0.375 - 0.290) \div 0.375$**

Therefore, the Adjusted Feed Rate equals 1.79. This is the feed rate that will equal 0.001 chip per tooth in the above example. This is the feed rate that must be used in the CNC program.



SINGLE POINT

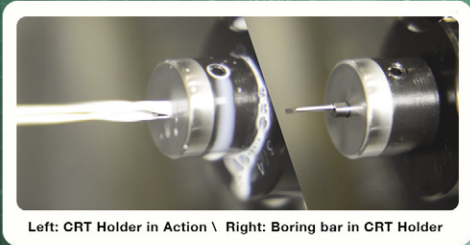

Left: CRT Holder in Action \ Right: Boring bar in CRT Holder

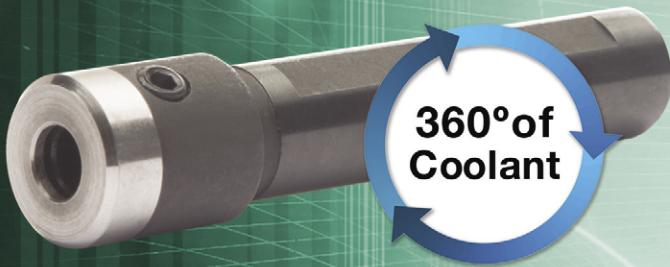

360° of
Coolant

**Holders
Radial Relief
Mini Boring Bars
Boring Bars
PCD/CBN Tipped
Helical Boring Bars**

**Profile Boring Bars
Back Chamfer
Acme Threading Tools
Qualified Tools
Thread Tools
Groove Tools**

SINGLE POINT TOOLS PRODUCT OVERVIEW

All single point tools are designed for internal machining on a lathe. The helical boring bars can be used for both lathe and mill applications. All cutting tools are made from premium submicron carbide and are stocked with and without an ALTiN+ coating. Technical information is available on pages 67-72.



CRT Holders (p.35)

CRT (Coolant Ring Technology) Holders are made with heat-treated steel, feature two lock-down screws for max rigidity, and have coolant flow that surrounds the tool for maximum cooling.



DH/DHF Holders (p.36)

Our economic holders come in two styles. DH Holders have two set screws and no flats. DHF Holders have two set screws and a flat.



QHC Holders (p.37)

QHC Holders have two flats on the shank, two coolant holes, and four set screws. QHC Holders can be used with a back stop. Available in inch or metric.

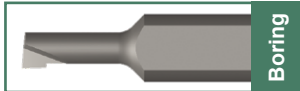

Mini Boring Bars (p.38)

Mini Boring Bars range in diameter from 0.015 to 0.045 inch. They are fluted for maximum strength.

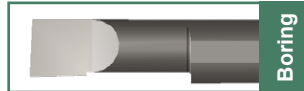

Radial Relief (p.39)

Radial Relief Boring Bars have a radial relief behind the cutting edge that provides for a strong cutting edge.

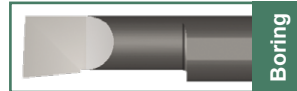

Qualified Boring Bars (p.40-41)

Qualified Boring Bars have an overall length that is qualified to ± 0.001 and a minimum bore diameter that is qualified to ± 0.0005 .

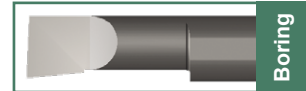

Boring Bars (p.42-43)

Boring Bars range in diameter from 0.050" to 0.490" and many different bore depths to achieve max rigidity.

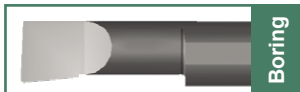

Radius (p.44-45)

Radius boring bars feature a corner radius that provides an improved surface finish.

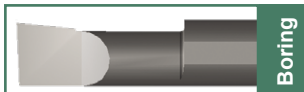

Left-Hand (p.46-47)

Left-Hand Boring Bars range in diameter from 0.050 to 0.490 inch and many different bore depths to achieve max rigidity.



Diamond Tipped (p.48-49)

PCD-Tipped Boring Bars cut abrasive non-ferrous materials. CBN-Tipped Boring Bars are for cutting ferrous metal over 45 RC.

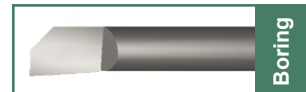

Helical (p.50-52)

Helical Boring Bars have a helical flute that produces less side cutting pressure, ideal for the cutting of unfavorable length-to-diameter ratios.



Back Chamfer (p.53)

Back Chamfer Boring Bars are designed to bore, cut a chamfer at the end of a hole, and cut thread reliefs.

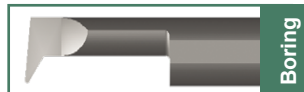

Profile Boring Bars (p.54)

Profile Boring Bars are ideal tools for internal profiling on CNC lathes.

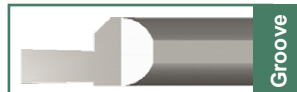

Face Groove (p.55)

Face Groove Tools cut a groove in the face of the part.



Undercut Groove (p.56)

Undercut Groove Tools come with and without a radius. The radius style can be used as a profile tool.



O-Ring Groove Tools (p.56)

O-Ring Groove Tools are ideal for machining a groove with tapered sides.



Retaining Ring (p.57-59)

Retaining Ring Groove Tools cut an internal groove with straight edges.



Groove - Full Radius (p.60-61)

Full Radius Groove Tools cut an internal groove with straight edges and a full radius.



Thread Tools (p.62)

Threading Tools come in many different sizes. This facilitates selecting the tool with maximum rigidity.



Left Hand Threading (p.63)

Threading Tools come in many different sizes. This facilitates selecting the tool with maximum rigidity.



Thread Tools Qualified (p.64)

Thread Tools Qualified have a positive top rake on the flute and a qualified length to facilitate quick tool changes.

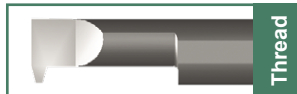

Acme Thread Tools (p.65-66)

These threading tools are available with acme or stub acme profiles.

SINGLE POINT TECHNICAL INFORMATION PAGES 67-72

COOLANT RING TECHNOLOGY

CRT HOLDERS

- Made with heat-treated steel
- Use with SCT qualified tools for quicker tool changes
- Features two lock-down screws for max rigidity
- Coolant flow surrounds the tool for maximum cooling

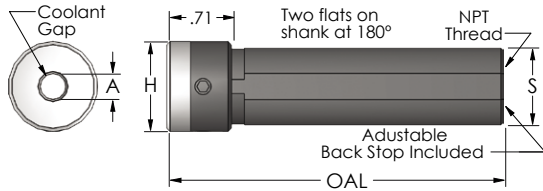

CRT HOLDERS
INCH

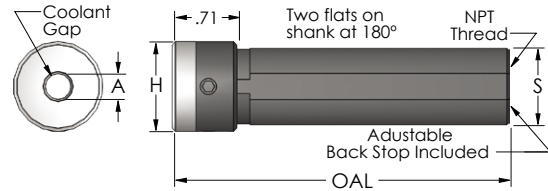

CRT HOLDERS
METRIC

"A" INSIDE DIA.	"S" SHANK DIA.	"H" HEAD DIA.	NPT THREAD	OAL	ORDER #	EDP #
0.1250	0.500	0.625	1/8-27NPT	2.84	CRT500-125	200500
0.1875	0.500	0.625	1/8-27NPT	2.84	CRT500-187	200503
0.2500	0.500	0.625	1/8-27NPT	2.84	CRT500-250	200506
0.1250	0.625	0.750	1/4-18NPT	3.34	CRT625-125	200509
0.1875	0.625	0.750	1/4-18NPT	3.34	CRT625-187	200512
0.2500	0.625	0.750	1/4-18NPT	3.34	CRT625-250	200515
0.3125	0.625	0.750	1/4-18NPT	3.34	CRT625-312	200518
0.1250	0.750	0.865	3/8-18NPT	3.34	CRT750-125	200521
0.1875	0.750	0.865	3/8-18NPT	3.34	CRT750-187	200524
0.2500	0.750	0.865	3/8-18NPT	3.34	CRT750-250	200527
0.3125	0.750	0.865	3/8-18NPT	3.34	CRT750-312	200530
0.3750	0.750	0.865	3/8-18NPT	3.34	CRT750-375	200533
0.1250	1.000	1.115	1/2-14NPT	3.34	CRT1000-125	200413
0.1875	1.000	1.115	1/2-14NPT	3.34	CRT1000-187	200416
0.2500	1.000	1.115	1/2-14NPT	3.34	CRT1000-250	200419
0.3125	1.000	1.115	1/2-14NPT	3.34	CRT1000-312	200422
0.3750	1.000	1.115	1/2-14NPT	3.34	CRT1000-375	200425
0.5000	1.000	1.1150	1/2-14NPT	3.34	CRT1000-500	200428

"A" INSIDE DIA.	"S" SHANK DIA.	"H" HEAD DIA.	NPT THREAD	OAL	ORDER #	EDP #
0.1250	12 MM	0.625	1/8-27NPT	2.84	CRT12M-125	200431
0.1875	12 MM	0.625	1/8-27NPT	2.84	CRT12M-187	200434
0.2500	12 MM	0.625	1/8-27NPT	2.84	CRT12M-250	200437
0.1250	16 MM	0.750	1/4-18NPT	3.34	CRT16M-125	200440
0.1875	16 MM	0.750	1/4-18NPT	3.34	CRT16M-187	200443
0.2500	16 MM	0.750	1/4-18NPT	3.34	CRT16M-250	200446
0.3125	16 MM	0.750	1/4-18NPT	3.34	CRT16M-312	200449
0.1250	20 MM	0.865	3/8-18NPT	3.34	CRT20M-125	200452
0.1875	20 MM	0.865	3/8-18NPT	3.34	CRT20M-187	200455
0.2500	20 MM	0.865	3/8-18NPT	3.34	CRT20M-250	200458
0.3125	20 MM	0.865	3/8-18NPT	3.34	CRT20M-312	200461
0.3750	20 MM	0.865	3/8-18NPT	3.34	CRT20M-375	200464
0.1250	22 MM	0.937	3/8-18NPT	3.34	CRT22M-125	200467
0.1875	22 MM	0.937	3/8-18NPT	3.34	CRT22M-187	200470
0.2500	22 MM	0.937	3/8-18NPT	3.34	CRT22M-250	200473
0.3125	22 MM	0.937	3/8-18NPT	3.34	CRT22M-312	200476
0.3750	22 MM	0.937	3/8-18NPT	3.34	CRT22M-375	200479
0.1250	25 MM	1.115	1/2-14NPT	3.34	CRT25M-125	200482
0.1875	25 MM	1.115	1/2-14NPT	3.34	CRT25M-187	200485
0.2500	25 MM	1.115	1/2-14NPT	3.34	CRT25M-250	200488
0.3125	25 MM	1.115	1/2-14NPT	3.34	CRT25M-312	200491
0.3750	25 MM	1.115	1/2-14NPT	3.34	CRT25M-375	200494
0.5000	25 MM	1.115	1/2-14NPT	3.34	CRT25M-500	200497

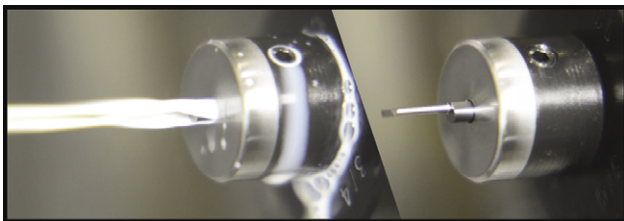

Click on the image above to view a video of the CRT in action

Replacement adjustable back stops are available.

[Go to Single Point Tools Overview](#)

SINGLE POINT HOLDERS

- Made with heat-treated steel
- Features two lock-down screws
- Holders available with or without flat

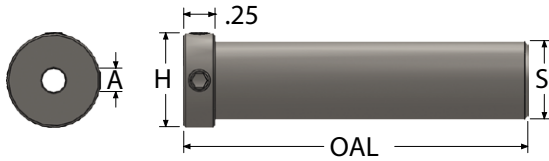

**DH HOLDERS
(WITHOUT FLAT)**

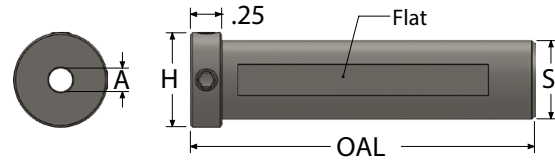

**DHF HOLDERS
(WITH FLAT)**

"A" INSIDE DIA.	"S" SHANK DIA.	"H" HEAD DIA.	OAL	ORDER #	EDP#
0.1250	0.375	0.500	2.00	DH37-1/8	200004
0.1562	0.375	0.500	2.00	DH37-5/32	200010
0.1875	0.375	0.500	2.00	DH37-3/16	200007
0.2187	0.375	0.500	2.00	DH37-7/32	200013
0.2500	0.375	0.500	2.00	DH37-1/4	200001
0.1250	0.500	0.625	2.75	DH50-1/8	200019
0.1562	0.500	0.625	2.75	DH50-5/32	200031
0.1875	0.500	0.625	2.75	DH50-3/16	200022
0.2187	0.500	0.625	2.75	DH50-7/32	200034
0.2500	0.500	0.625	2.75	DH50-1/4	200016
0.3125	0.500	0.625	2.75	DH50-5/16	200028
0.3750	0.500	0.625	2.75	DH50-3/8	200025
0.1250	0.625	0.750	2.75	DH62-1/8	200040
0.1562	0.625	0.750	2.75	DH62-5/32	200052
0.1875	0.625	0.750	2.75	DH62-3/16	200043
0.2187	0.625	0.750	2.75	DH62-7/32	200055
0.2500	0.625	0.750	2.75	DH62-1/4	200037
0.3125	0.625	0.750	2.75	DH62-5/16	200049
0.3750	0.625	0.750	2.75	DH62-3/8	200046
0.1250	0.750	0.875	2.75	DH75-1/8	200064
0.1875	0.750	0.875	2.75	DH75-3/16	200067
0.2500	0.750	0.875	2.75	DH75-1/4	200061
0.3125	0.750	0.875	2.75	DH75-5/16	200073
0.3750	0.750	0.875	2.75	DH75-3/8	200070
0.5000	0.750	0.875	2.75	DH75-1/2	200058

"A" INSIDE DIA.	"S" SHANK DIA.	"H" HEAD DIA.	OAL	ORDER #	EDP #
0.1250	0.375	0.500	2.00	DHF37-1/8	200104
0.1562	0.375	0.500	2.00	DHF37-5/32	200110
0.1875	0.375	0.500	2.00	DHF37-3/16	200107
0.2187	0.375	0.500	2.00	DHF37-7/32	200113
0.2500	0.375	0.500	2.00	DHF37-1/4	200101
0.1250	0.500	0.625	2.75	DHF50-1/8	200119
0.1562	0.500	0.625	2.75	DHF50-5/32	200131
0.1875	0.500	0.625	2.75	DHF50-3/16	200122
0.2187	0.500	0.625	2.75	DHF50-7/32	200134
0.2500	0.500	0.625	2.75	DHF50-1/4	200116
0.3125	0.500	0.625	2.75	DHF50-5/16	200128
0.3750	0.500	0.625	2.75	DHF50-3/8	200125
0.1250	0.625	0.750	2.75	DHF62-1/8	200140
0.1562	0.625	0.750	2.75	DHF62-5/32	200152
0.1875	0.625	0.750	2.75	DHF62-3/16	200143
0.2187	0.625	0.750	2.75	DHF62-7/32	200155
0.2500	0.625	0.750	2.75	DHF62-1/4	200137
0.3125	0.625	0.750	2.75	DHF62-5/16	200149
0.3750	0.625	0.750	2.75	DHF62-3/8	200146
0.1250	0.750	0.875	2.75	DHF75-1/8	200164
0.1875	0.750	0.875	2.75	DHF75-3/16	200167
0.2500	0.750	0.875	2.75	DHF75-1/4	200161
0.3125	0.750	0.875	2.75	DHF75-5/16	200173
0.3750	0.750	0.875	2.75	DHF75-3/8	200170
0.5000	0.750	0.875	2.75	DHF75-1/2	200158

[Go to Single Point Tools Overview](#)

SINGLE POINT COOLANT HOLDERS

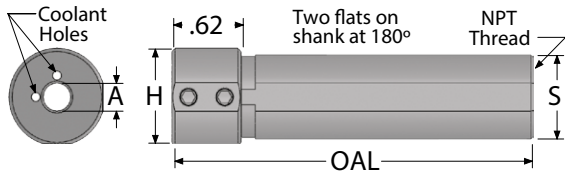

- Made with heat-treated steel
- Four lock-down screws for maximum rigidity
- Engineered for maximum coolant flow

QHC HOLDERS (INCH)

"A" INSIDE DIA.	"S" SHANK DIA.	"H" HEAD DIA.	NPT THREAD	OAL	ORDER #	EDP#
0.1250	0.375	0.500	1/16-27NPT	2.50	QHC37-1/8	200252
0.1562	0.375	0.500	1/16-27NPT	2.50	QHC37-5/32	200258
0.1875	0.375	0.500	1/16-27NPT	2.50	QHC37-3/16	200255
0.1250	0.500	0.625	1/8-27NPT	2.75	QHC50-1/8	200267
0.1875	0.500	0.625	1/8-27NPT	2.75	QHC50-3/16	200270
0.2500	0.500	0.625	1/8-27NPT	2.75	QHC50-1/4	200264
0.1250	0.625	0.750	1/4-18NPT	3.25	QHC62-1/8	200279
0.1562	0.625	0.750	1/4-18NPT	3.25	QHC62-5/32	200285
0.1875	0.625	0.750	1/4-18NPT	3.25	QHC62-3/16	200282
0.2187	0.625	0.750	1/4-18NPT	3.25	QHC62-7/32	200288
0.2500	0.625	0.750	1/4-18NPT	3.25	QHC62-1/4	200276

QHC HOLDERS (INCH)

"A" INSIDE DIA.	"S" SHANK DIA.	"H" HEAD DIA.	NPT THREAD	OAL	ORDER #	EDP #
0.1250	0.750	0.865	3/8-18NPT	3.25	QHC75-1/8	200297
0.1562	0.750	0.865	3/8-18NPT	3.25	QHC75-5/32	200309
0.1875	0.750	0.865	3/8-18NPT	3.25	QHC75-3/16	200300
0.2187	0.750	0.865	3/8-18NPT	3.25	QHC75-7/32	200312
0.2500	0.750	0.865	3/8-18NPT	3.25	QHC75-1/4	200294
0.3125	0.750	0.865	3/8-18NPT	3.25	QHC75-5/16	200306
0.3750	0.750	0.865	3/8-18NPT	3.25	QHC75-3/8	200303
0.1250	1.000	1.115	1/2-14NPT	3.25	QHC10-1/8	200207
0.1875	1.000	1.115	1/2-14NPT	3.25	QHC10-3/16	200210
0.2500	1.000	1.115	1/2-14NPT	3.25	QHC10-1/4	200204
0.3125	1.000	1.115	1/2-14NPT	3.25	QHC10-5/16	200216
0.3750	1.000	1.115	1/2-14NPT	3.25	QHC10-3/8	200213
0.5000	1.000	1.115	1/2-14NPT	3.25	QHC10-1/2	200201

QHC HOLDERS (METRIC)

"A" INSIDE DIA.	"S" SHANK DIA.	"H" HEAD DIA.	NPT THREAD	OAL	ORDER #	EDP#
0.1250	20mm	0.865	3/8-18NPT	3.25	QHC20-1/8	200225
0.1875	20mm	0.865	3/8-18NPT	3.25	QHC20-3/16	200228
0.2500	20mm	0.865	3/8-18NPT	3.25	QHC20-1/4	200222
0.3125	20mm	0.865	3/8-18NPT	3.25	QHC20-5/16	200234
0.3750	20mm	0.865	3/8-18NPT	3.25	QHC20-3/8	200231

QHC HOLDERS (METRIC)

"A" INSIDE DIA.	"S" SHANK DIA.	"H" HEAD DIA.	NPT THREAD	OAL	ORDER #	EDP#
0.1250	22mm	0.865	3/8-18NPT	3.25	QHC22-1/8	200240
0.1875	22mm	0.865	3/8-18NPT	3.25	QHC22-3/16	200243
0.2500	22mm	0.865	3/8-18NPT	3.25	QHC22-1/4	200237
0.3125	22mm	0.865	3/8-18NPT	3.25	QHC22-5/16	200249
0.3750	22mm	0.865	3/8-18NPT	3.25	QHC22-3/8	200246

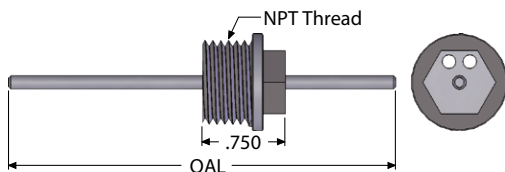

- Adjustable back stop for quick tool change
- Ideal for qualified threading tools
- Engineered for maximum coolant flow
- Ideal for qualified boring bars

BACK STOPS (QHC SERIES)

NPT THREAD	STOP ROD DIAMETER	STOP ROD OAL	HOLDER SERIES	ORDER #	EDP#
1/16-27NPT	0.093	2.75	QHC37	QHC37-BKS	200261
1/8-27NPT	0.125	3.00	QHC50	QHC50-BKS	200273
1/4-18NPT	0.125	3.00	QHC62	QHC62-BKS	200291
3/8-18NPT	0.125	3.00	QHC75	QHC75-BKS	200315
1/2-14NPT	0.125	3.50	QHC10	QHC10-BKS	200219

[Go to Single Point Tools Overview](#)

MINI BORING BARS - SOLID CARBIDE

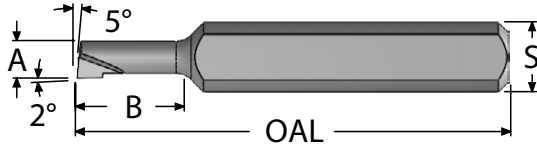

- Flute engineered for maximum strength
- ALTiN+ coating for improved surface finish
- Made with premium submicron grade carbide
- Starts at 0.015 minimum bore

"A" MIN BORE	"B" MAX DEPTH	"S" SHANK DIA.	OAL	ORDER #		EDP #	
				UNCOATED	AITiN+	UNCOATED	AITiN+
0.015	0.050	0.125	1.50	MB015050	MB015050A	210001	210071
0.020	0.075	0.125	1.50	MB020075	MB020075A	210004	210074
0.025	0.100	0.125	1.50	MB025100	MB025100A	210007	210077
0.025	0.125	0.125	1.50	MB025125	MB025125A	210010	210080
0.030	0.100	0.125	1.50	MB030100	MB030100A	210013	210083
0.030	0.125	0.125	1.50	MB030125	MB030125A	210016	210086
0.030	0.150	0.125	1.50	MB030150	MB030150A	210019	210089
0.035	0.100	0.125	1.50	MB035100	MB035100A	210022	210092
0.035	0.150	0.125	1.50	MB035150	MB035150A	210025	210095
0.035	0.200	0.125	1.50	MB035200	MB035200A	210028	210098
0.040	0.100	0.125	1.50	MB040100	MB040100A	210031	210101
0.040	0.150	0.125	1.50	MB040150	MB040150A	210034	210104
0.040	0.200	0.125	1.50	MB040200	MB040200A	210037	210107
0.040	0.250	0.125	1.50	MB040250	MB040250A	210040	210110
0.045	0.100	0.125	1.50	MB045100	MB045100A	210043	210113
0.045	0.150	0.125	1.50	MB045150	MB045150A	210046	210116
0.045	0.200	0.125	1.50	MB045200	MB045200A	210049	210119
0.045	0.250	0.125	1.50	MB045250	MB045250A	210052	210122
0.045	0.300	0.125	1.50	MB045300	MB045300A	210055	210125
0.045	0.350	0.125	1.50	MB045350	MB045350A	210058	210128

[Go to Single Point Tools Overview](#)

BORING BARS - RADIAL RELIEF - SOLID CARBIDE

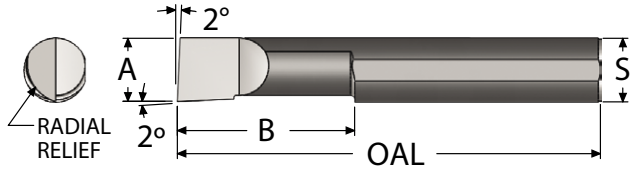

- Made with premium submicron grade carbide
- ALTiN+ coating extends tool life
- Radial relieved cutting clearance for max strength
- Polished flute face for optimal performance

"A" MIN BORE	"B" MAX DEPTH	"S" SHANK DIA.	OAL	ORDER #		EDP #	
				UNCOATED	AITiN+	UNCOATED	AITiN+
0.060	0.125	0.125	1.50	BB61	BB61A	210342	211062
0.060	0.250	0.125	1.50	BB62	BB62A	210345	211065
0.060	0.375	0.125	1.50	BB63	BB63A	210348	211068
0.060	0.500	0.125	1.50	BB64	BB64A	210351	211071
0.075	0.125	0.125	1.50	BB71	BB71A	210354	211074
0.075	0.250	0.125	1.50	BB72	BB72A	210357	211077
0.075	0.375	0.125	1.50	BB73	BB73A	210360	211080
0.075	0.500	0.125	1.50	BB74	BB74A	210363	211083
0.090	0.125	0.125	1.50	BB91	BB91A	210366	211086
0.090	0.250	0.125	1.50	BB92	BB92A	210369	211089
0.090	0.375	0.125	1.50	BB93	BB93A	210372	211092
0.090	0.500	0.125	1.50	BB94	BB94A	210375	211095
0.090	0.625	0.125	1.50	BB95	BB95A	210378	211098
0.105	0.250	0.125	1.50	BB102	BB102A	210201	210921
0.105	0.375	0.125	1.50	BB103	BB103A	210204	210924
0.105	0.500	0.125	1.50	BB104	BB104A	210207	210927
0.105	0.625	0.125	1.50	BB105	BB105A	210210	210930
0.120	0.250	0.125	1.50	BB122	BB122A	210213	210933
0.120	0.375	0.125	1.50	BB123	BB123A	210216	210936
0.120	0.500	0.125	1.50	BB124	BB124A	210219	210939
0.120	0.625	0.125	1.50	BB125	BB125A	210222	210942
0.120	0.750	0.125	1.50	BB126	BB126A	210225	210945
0.155	0.375	0.1875	2.00	BB153	BB153A	210228	210948
0.155	0.500	0.1875	2.00	BB154	BB154A	210231	210951
0.155	0.625	0.1875	2.00	BB155	BB155A	210234	210954
0.155	0.750	0.1875	2.00	BB156	BB156A	210237	210957
0.155	1.000	0.1875	2.00	BB158	BB158A	210240	210960
0.185	0.375	0.1875	2.00	BB183	BB183A	210246	210966
0.185	0.500	0.1875	2.00	BB184	BB184A	210249	210969
0.185	0.625	0.1875	2.00	BB185	BB185A	210252	210972
0.185	0.750	0.1875	2.00	BB186	BB186A	210255	210975
0.185	1.000	0.1875	2.00	BB188	BB188A	210258	210978
0.185	1.250	0.1875	2.00	BB1812	BB1812A	210243	210963

"A" MIN BORE	"B" MAX DEPTH	"S" SHANK DIA.	OAL	ORDER #		EDP #	
				UNCOATED	AITiN+	UNCOATED	AITiN+
0.220	0.500	0.250	2.00	BB224	BB224A	210264	210984
0.220	0.625	0.250	2.00	BB225	BB225A	210267	210987
0.220	0.750	0.250	2.00	BB226	BB226A	210270	210990
0.220	1.000	0.250	2.00	BB228	BB228A	210273	210993
0.220	1.250	0.250	2.50	BB2212	BB2212A	210261	210981
0.248	0.500	0.250	2.00	BB254	BB254A	210282	211002
0.248	0.625	0.250	2.00	BB255	BB255A	210285	211005
0.248	0.750	0.250	2.00	BB256	BB256A	210288	211008
0.248	1.000	0.250	2.00	BB258	BB258A	210291	211011
0.248	1.250	0.250	2.50	BB2512	BB2512A	210276	210996
0.248	1.500	0.250	2.50	BB2514	BB2514A	210279	210999
0.310	0.500	0.3125	2.00	BB314	BB314A	210303	211023
0.310	0.750	0.3125	2.00	BB316	BB316A	210306	211026
0.310	0.750	0.3125	2.50	BB316L	BB316LA	210309	211029
0.310	1.000	0.3125	2.50	BB318	BB318A	210312	211032
0.310	1.250	0.3125	2.50	BB3112	BB3112A	210294	211014
0.310	1.500	0.3125	2.50	BB3114	BB3114A	210297	211017
0.310	1.750	0.3125	3.00	BB3116	BB3116A	210300	211020
0.373	0.500	0.375	2.00	BB374	BB374A	210330	211050
0.373	0.750	0.375	2.00	BB376	BB376A	210333	211053
0.373	0.750	0.375	2.50	BB376L	BB376LA	210336	211056
0.373	1.000	0.375	2.50	BB378	BB378A	210339	211059
0.373	1.250	0.375	2.50	BB3712	BB3712A	210315	211035
0.373	1.500	0.375	2.50	BB3714	BB3714A	210318	211038
0.373	1.500	0.375	3.00	BB3714L	BB3714LA	210321	211041
0.373	1.750	0.375	3.00	BB3716	BB3716A	210324	211044
0.373	2.000	0.375	3.00	BB3718	BB3718A	210327	211047

[Go to Single Point Tools Overview](#)

QUALIFIED BORING BARS - SOLID CARBIDE

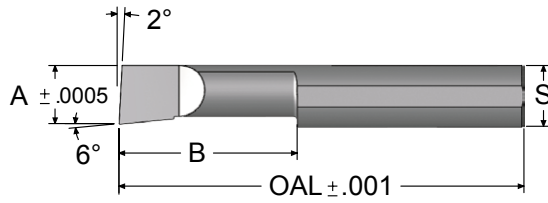

- Qualified length provides quicker tool changes
- Overall length is qualified to ± 0.001
- Minimum bore diameter is qualified to ± 0.0005
- Precision ground flat for guaranteed tool orientation

"A" MIN BORE	"B" MAX DEPTH	"S" SHANK DIA.	OAL	ORDER #		EDP #	
				UNCOATED	AITIN+	UNCOATED	AITIN+
0.048	0.150	0.125	1.50	BQ050150	BQ050150A	217201	217963
0.048	0.200	0.125	1.50	BQ050200	BQ050200A	217204	217966
0.048	0.300	0.125	1.50	BQ050300	BQ050300A	217207	217969
0.048	0.400	0.125	1.50	BQ050400	BQ050400A	217210	217972
0.058	0.150	0.125	1.50	BQ060150	BQ060150A	217213	217975
0.058	0.200	0.125	1.50	BQ060200	BQ060200A	217216	217978
0.058	0.300	0.125	1.50	BQ060300	BQ060300A	217219	217981
0.058	0.400	0.125	1.50	BQ060400	BQ060400A	217222	217984
0.058	0.500	0.125	1.50	BQ060500	BQ060500A	217225	217987
0.078	0.150	0.125	1.50	BQ080150	BQ080150A	217228	217990
0.078	0.200	0.125	1.50	BQ080200	BQ080200A	217231	217993
0.078	0.300	0.125	1.50	BQ080300	BQ080300A	217234	217996
0.078	0.400	0.125	1.50	BQ080400	BQ080400A	217237	217999
0.078	0.500	0.125	1.50	BQ080500	BQ080500A	217240	218002
0.078	0.600	0.125	1.50	BQ080600	BQ080600A	217243	218005
0.098	0.150	0.125	1.50	BQ100150	BQ100150A	217246	218008
0.098	0.200	0.125	1.50	BQ100200	BQ100200A	217249	218011
0.098	0.300	0.125	1.50	BQ100300	BQ100300A	217252	218014
0.098	0.400	0.125	1.50	BQ100400	BQ100400A	217255	218017
0.098	0.500	0.125	1.50	BQ100500	BQ100500A	217258	218020
0.098	0.600	0.125	1.50	BQ100600	BQ100600A	217261	218023
0.098	0.700	0.125	1.50	BQ100700	BQ100700A	217264	218026
0.108	0.150	0.125	1.50	BQ110150	BQ110150A	217267	218029
0.108	0.200	0.125	1.50	BQ110200	BQ110200A	217270	218032
0.108	0.300	0.125	1.50	BQ110300	BQ110300A	217273	218035
0.108	0.400	0.125	1.50	BQ110400	BQ110400A	217276	218038
0.108	0.500	0.125	1.50	BQ110500	BQ110500A	217279	218041
0.108	0.600	0.125	1.50	BQ110600	BQ110600A	217282	218044
0.108	0.700	0.125	1.50	BQ110700	BQ110700A	217285	218047
0.118	0.250	0.1875	2.00	BQ120250	BQ120250A	217288	218050
0.118	0.350	0.1875	2.00	BQ120350	BQ120350A	217291	218053
0.118	0.500	0.1875	2.00	BQ120500	BQ120500A	217294	218056
0.118	0.600	0.1875	2.00	BQ120600	BQ120600A	217297	218059
0.118	0.700	0.1875	2.00	BQ120700	BQ120700A	217300	218062
0.118	0.800	0.1875	2.00	BQ120800	BQ120800A	217303	218065

"A" MIN BORE	"B" MAX DEPTH	"S" SHANK DIA.	OAL	ORDER #		EDP #	
				UNCOATED	AITIN+	UNCOATED	AITIN+
0.138	0.250	0.1875	2.00	BQ140250	BQ140250A	217306	218068
0.138	0.400	0.1875	2.00	BQ140400	BQ140400A	217309	218071
0.138	0.500	0.1875	2.00	BQ140500	BQ140500A	217312	218074
0.138	0.600	0.1875	2.00	BQ140600	BQ140600A	217315	218077
0.138	0.700	0.1875	2.00	BQ140700	BQ140700A	217318	218080
0.138	0.750	0.1875	2.00	BQ140750	BQ140750A	217321	218083
0.138	0.800	0.1875	2.00	BQ140800	BQ140800A	217324	218086
0.158	0.250	0.1875	2.00	BQ160250	BQ160250A	217330	218092
0.158	0.400	0.1875	2.00	BQ160400	BQ160400A	217333	218095
0.158	0.500	0.1875	2.00	BQ160500	BQ160500A	217336	218098
0.158	0.600	0.1875	2.00	BQ160600	BQ160600A	217339	218101
0.158	0.750	0.1875	2.00	BQ160750	BQ160750A	217342	218104
0.158	0.900	0.1875	2.00	BQ160900	BQ160900A	217345	218107
0.158	1.000	0.1875	2.00	BQ1601000	BQ1601000A	217327	218089
0.178	0.350	0.250	2.50	BQ180350	BQ180350A	217360	218122
0.178	0.500	0.250	2.50	BQ180500	BQ180500A	217363	218125
0.178	0.600	0.250	2.50	BQ180600	BQ180600A	217366	218128
0.178	0.750	0.250	2.50	BQ180750	BQ180750A	217369	218131
0.178	0.900	0.250	2.50	BQ180900	BQ180900A	217372	218134
0.178	1.000	0.250	2.50	BQ1801000	BQ1801000A	217348	218110
0.178	1.100	0.250	2.50	BQ1801100	BQ1801100A	217351	218113
0.178	1.250	0.250	2.50	BQ1801250	BQ1801250A	217354	218116
0.178	1.500	0.250	2.50	BQ1801500	BQ1801500A	217357	218119
0.198	0.400	0.250	2.50	BQ200400	BQ200400A	217387	218149
0.198	0.500	0.250	2.50	BQ200500	BQ200500A	217390	218152
0.198	0.600	0.250	2.50	BQ200600	BQ200600A	217393	218155
0.198	0.700	0.250	2.50	BQ200700	BQ200700A	217396	218158
0.198	0.800	0.250	2.50	BQ200800	BQ200800A	217399	218161
0.198	0.900	0.250	2.50	BQ200900	BQ200900A	217402	218164
0.198	1.000	0.250	2.50	BQ2001000	BQ2001000A	217375	218137
0.198	1.100	0.250	2.50	BQ2001100	BQ2001100A	217378	218140
0.198	1.200	0.250	2.50	BQ2001200	BQ2001200A	217381	218143
0.198	1.300	0.250	2.50	BQ2001300	BQ2001300A	217384	218146

* The B050 and the B060 series have 3° side clearance.

[Go to Single Point Tools Overview](#)

Compatible holders with backstops: see pages 35 and 37.

QUALIFIED BORING BARS - SOLID CARBIDE

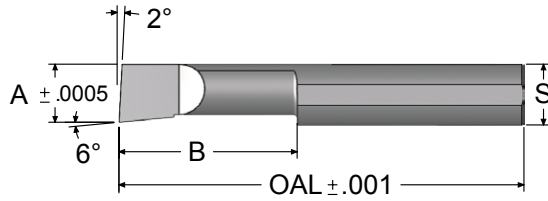

- Qualified length provides quicker tool changes
- Overall length is qualified to ± 0.001
- Minimum bore diameter is qualified to ± 0.0005
- Precision ground flat for guaranteed tool orientation

"A" MIN BORE	"B" MAX DEPTH	"S" SHANK DIA.	OAL	ORDER #		EDP #	
				UNCOATED	AITiN+	UNCOATED	AITiN+
0.228	0.400	0.3125	2.50	BQ230400	BQ230400A	217429	218191
0.228	0.500	0.3125	2.50	BQ230500	BQ230500A	217432	218194
0.228	0.600	0.3125	2.50	BQ230600	BQ230600A	217435	218197
0.228	0.700	0.3125	2.50	BQ230700	BQ230700A	217438	218200
0.228	0.800	0.3125	2.50	BQ230800	BQ230800A	217441	218203
0.228	0.900	0.3125	2.50	BQ230900	BQ230900A	217444	218206
0.228	1.000	0.3125	2.50	BQ2301000	BQ2301000A	217405	218167
0.228	1.100	0.3125	2.50	BQ2301100	BQ2301100A	217408	218170
0.228	1.150	0.3125	2.50	BQ2301150	BQ2301150A	217411	218173
0.228	1.200	0.3125	2.50	BQ2301200	BQ2301200A	217414	218176
0.228	1.250	0.3125	2.50	BQ2301250	BQ2301250A	217417	218179
0.228	1.400	0.3125	2.50	BQ2301400	BQ2301400A	217420	218182
0.228	1.500	0.3125	2.50	BQ2301500	BQ2301500A	217423	218185
0.228	1.600	0.3125	3.00	BQ2301600	BQ2301600A	217426	218188
0.288	0.500	0.3125	2.50	BQ290500	BQ290500A	217468	218230
0.288	0.600	0.3125	2.50	BQ290600	BQ290600A	217471	218233
0.288	0.750	0.3125	2.50	BQ290750	BQ290750A	217474	218236
0.288	0.900	0.3125	2.50	BQ290900	BQ290900A	217477	218239
0.288	1.000	0.3125	2.50	BQ2901000	BQ2901000A	217447	218209
0.288	1.100	0.3125	2.50	BQ2901100	BQ2901100A	217450	218212
0.288	1.250	0.3125	2.50	BQ2901250	BQ2901250A	217453	218215
0.288	1.350	0.3125	2.50	BQ2901350	BQ2901350A	217456	218218
0.288	1.500	0.3125	2.50	BQ2901500	BQ2901500A	217459	218221
0.288	1.600	0.3125	3.00	BQ2901600	BQ2901600A	217462	218224
0.288	1.750	0.3125	3.00	BQ2901750	BQ2901750A	217465	218227
0.318	0.500	0.375	2.50	BQ320500	BQ320500A	217507	218269
0.318	0.600	0.375	2.50	BQ320600	BQ320600A	217510	218272
0.318	0.750	0.375	2.50	BQ320750	BQ320750A	217513	218275
0.318	0.900	0.375	2.50	BQ320900	BQ320900A	217516	218278
0.318	1.000	0.375	2.50	BQ3201000	BQ3201000A	217480	218242
0.318	1.100	0.375	2.50	BQ3201100	BQ3201100A	217483	218245
0.318	1.250	0.375	2.50	BQ3201250	BQ3201250A	217486	218248
0.318	1.500	0.375	2.50	BQ3201500	BQ3201500A	217489	218251
0.318	1.600	0.375	3.00	BQ3201600	BQ3201600A	217492	218254
0.318	1.800	0.375	3.00	BQ3201800	BQ3201800A	217495	218257
0.318	2.000	0.375	4.00	BQ3202000	BQ3202000A	217498	218260
0.318	2.500	0.375	4.00	BQ3202500	BQ3202500A	217501	218263
0.318	3.000	0.375	4.00	BQ3203000	BQ3203000A	217504	218266

"A" MIN BORE	"B" MAX DEPTH	"S" SHANK DIA.	OAL	ORDER #		EDP #	
				UNCOATED	AITiN+	UNCOATED	AITiN+
0.358	0.500	0.375	2.50	BQ360500	BQ360500A	217546	218308
0.358	0.600	0.375	2.50	BQ360600	BQ360600A	217549	218311
0.358	0.750	0.375	2.50	BQ360750	BQ360750A	217552	218314
0.358	0.900	0.375	2.50	BQ360900	BQ360900A	217555	218317
0.358	1.000	0.375	2.50	BQ3601000	BQ3601000A	217519	218281
0.358	1.150	0.375	2.50	BQ3601150	BQ3601150A	217522	218284
0.358	1.250	0.375	2.50	BQ3601250	BQ3601250A	217525	218287
0.358	1.500	0.375	2.50	BQ3601500	BQ3601500A	217528	218290
0.358	1.600	0.375	3.00	BQ3601600	BQ3601600A	217531	218293
0.358	1.800	0.375	3.00	BQ3601800	BQ3601800A	217534	218296
0.358	2.000	0.375	4.00	BQ3602000	BQ3602000A	217537	218299
0.358	2.500	0.375	4.00	BQ3602500	BQ3602500A	217540	218302
0.358	3.000	0.375	4.00	BQ3603000	BQ3603000A	217543	218305
0.488	0.750	0.500	3.00	BQ490750	BQ490750A	217579	218341
0.488	1.000	0.500	3.00	BQ4901000	BQ4901000A	217558	218320
0.488	1.250	0.500	3.00	BQ4901250	BQ4901250A	217561	218323
0.488	1.500	0.500	3.00	BQ4901500	BQ4901500A	217564	218326
0.488	2.000	0.500	4.00	BQ4902000	BQ4902000A	217567	218329
0.488	2.500	0.500	4.00	BQ4902500	BQ4902500A	217570	218332
0.488	2.600	0.500	4.00	BQ4902600	BQ4902600A	217573	218335
0.488	2.750	0.500	4.00	BQ4902750	BQ4902750A	217576	218338

[Go to Single Point Tools Overview](#)

BORING BARS - SOLID CARBIDE

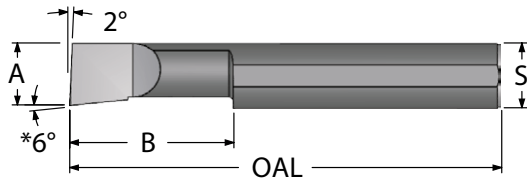

- Made with premium submicron grade carbide
- ALTiN+ coating for higher Surface Feet per Minute
- Precision ground flat for guaranteed tool orientation

"A" MIN BORE	"B" MAX DEPTH	"S" SHANK DIA.	OAL	ORDER #		EDP #	
				UNCOATED	AlTiN+	UNCOATED	AlTiN+
0.050	0.150	0.125	1.50	B050150	B050150A	211401	212955
0.050	0.200	0.125	1.50	B050200	B050200A	211404	212958
0.050	0.300	0.125	1.50	B050300	B050300A	211407	212961
0.050	0.400	0.125	1.50	B050400	B050400A	211410	212964
0.060	0.150	0.125	1.50	B060150	B060150A	211413	212967
0.060	0.200	0.125	1.50	B060200	B060200A	211416	212970
0.060	0.300	0.125	1.50	B060300	B060300A	211419	212973
0.060	0.400	0.125	1.50	B060400	B060400A	211422	212976
0.060	0.500	0.125	1.50	B060500	B060500A	211425	212979
0.080	0.150	0.125	1.50	B080150	B080150A	211428	212982
0.080	0.200	0.125	1.50	B080200	B080200A	211431	212985
0.080	0.300	0.125	1.50	B080300	B080300A	211434	212988
0.080	0.400	0.125	1.50	B080400	B080400A	211437	212991
0.080	0.500	0.125	1.50	B080500	B080500A	211440	212994
0.080	0.600	0.125	1.50	B080600	B080600A	211443	212997
0.100	0.150	0.125	1.50	B100150	B100150A	211446	213000
0.100	0.200	0.125	1.50	B100200	B100200A	211449	213003
0.100	0.300	0.125	1.50	B100300	B100300A	211452	213006
0.100	0.400	0.125	1.50	B100400	B100400A	211455	213009
0.100	0.500	0.125	1.50	B100500	B100500A	211458	213012
0.100	0.600	0.125	1.50	B100600	B100600A	211461	213015
0.100	0.700	0.125	1.50	B100700	B100700A	211464	213018
0.110	0.150	0.125	1.50	B110150	B110150A	211467	213021
0.110	0.200	0.125	1.50	B110200	B110200A	211470	213024
0.110	0.300	0.125	1.50	B110300	B110300A	211473	213027
0.110	0.400	0.125	1.50	B110400	B110400A	211476	213030
0.110	0.500	0.125	1.50	B110500	B110500A	211479	213033
0.110	0.600	0.125	1.50	B110600	B110600A	211482	213036
0.110	0.700	0.125	1.50	B110700	B110700A	211485	213039
0.120	0.250	0.1875	2.00	B120250	B120250A	211488	213042
0.120	0.350	0.1875	2.00	B120350	B120350A	211491	213045
0.120	0.500	0.1875	2.00	B120500	B120500A	211494	213048
0.120	0.600	0.1875	2.00	B120600	B120600A	211497	213051
0.120	0.700	0.1875	2.00	B120700	B120700A	211500	213054
0.120	0.800	0.1875	2.00	B120800	B120800A	211503	213057

"A" MIN BORE	"B" MAX DEPTH	"S" SHANK DIA.	OAL	ORDER #		EDP #	
				UNCOATED	AlTiN+	UNCOATED	AlTiN+
0.140	0.250	0.1875	2.00	B140250	B140250A	211506	213060
0.140	0.400	0.1875	2.00	B140400	B140400A	211509	213063
0.140	0.500	0.1875	2.00	B140500	B140500A	211512	213066
0.140	0.600	0.1875	2.00	B140600	B140600A	211515	213069
0.140	0.700	0.1875	2.00	B140700	B140700A	211518	213072
0.140	0.750	0.1875	2.00	B140750	B140750A	211521	213075
0.140	0.800	0.1875	2.00	B140800	B140800A	211524	213078
0.160	0.250	0.1875	2.00	B160250	B160250A	211530	213084
0.160	0.400	0.1875	2.00	B160400	B160400A	211533	213087
0.160	0.500	0.1875	2.00	B160500	B160500A	211536	213090
0.160	0.600	0.1875	2.00	B160600	B160600A	211539	213093
0.160	0.750	0.1875	2.00	B160750	B160750A	211542	213096
0.160	0.900	0.1875	2.00	B160900	B160900A	211545	213099
0.160	1.000	0.1875	2.00	B1601000	B1601000A	211527	213081
0.180	0.350	0.250	2.50	B180350	B180350A	211560	213114
0.180	0.500	0.250	2.50	B180500	B180500A	211563	213117
0.180	0.600	0.250	2.50	B180600	B180600A	211566	213120
0.180	0.750	0.250	2.50	B180750	B180750A	211569	213123
0.180	0.900	0.250	2.50	B180900	B180900A	211572	213126
0.180	1.000	0.250	2.50	B1801000	B1801000A	211548	213102
0.180	1.100	0.250	2.50	B1801100	B1801100A	211551	213105
0.180	1.250	0.250	2.50	B1801250	B1801250A	211554	213108
0.180	1.500	0.250	2.50	B1801500	B1801500A	211557	213111
0.200	0.400	0.250	2.50	B200400	B200400A	211587	213141
0.200	0.500	0.250	2.50	B200500	B200500A	211590	213144
0.200	0.600	0.250	2.50	B200600	B200600A	211593	213147
0.200	0.700	0.250	2.50	B200700	B200700A	211596	213150
0.200	0.800	0.250	2.50	B200800	B200800A	211599	213153
0.200	0.900	0.250	2.50	B200900	B200900A	211602	213156
0.200	1.000	0.250	2.50	B2001000	B2001000A	211575	213129
0.200	1.100	0.250	2.50	B2001100	B2001100A	211578	213132
0.200	1.200	0.250	2.50	B2001200	B2001200A	211581	213135
0.200	1.300	0.250	2.50	B2001300	B2001300A	211584	213138

[Go to Single Point Tools Overview](#)

* The B050 and the B060 series have 3° side clearance.

BORING BARS - SOLID CARBIDE

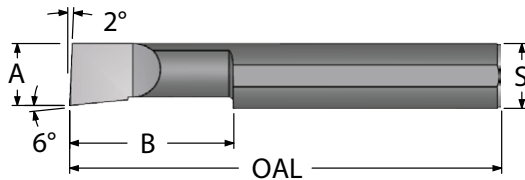

- ALTiN+ coating extends tool life
- Elliptically ground neck provides maximum strength
- Precision ground shank flat guarantees tool orientation

"A" MIN BORE	"B" MAX DEPTH	"S" SHANK DIA.	OAL	ORDER #		EDP #	
				UNCOATED	AITiN+	UNCOATED	AITiN+
0.230	0.400	0.3125	2.50	B230400	B230400A	211629	213183
0.230	0.500	0.3125	2.50	B230500	B230500A	211632	213186
0.230	0.600	0.3125	2.50	B230600	B230600A	211635	213189
0.230	0.700	0.3125	2.50	B230700	B230700A	211638	213192
0.230	0.800	0.3125	2.50	B230800	B230800A	211641	213195
0.230	0.900	0.3125	2.50	B230900	B230900A	211644	213198
0.230	1.000	0.3125	2.50	B2301000	B2301000A	211605	213159
0.230	1.100	0.3125	2.50	B2301100	B2301100A	211608	213162
0.230	1.150	0.3125	2.50	B2301150	B2301150A	211611	213165
0.230	1.200	0.3125	2.50	B2301200	B2301200A	211614	213168
0.230	1.250	0.3125	2.50	B2301250	B2301250A	211617	213171
0.230	1.400	0.3125	2.50	B2301400	B2301400A	211620	213174
0.230	1.500	0.3125	2.50	B2301500	B2301500A	211623	213177
0.230	1.600	0.3125	3.00	B2301600	B2301600A	211626	213180
0.290	0.500	0.3125	2.50	B290500	B290500A	211668	213222
0.290	0.600	0.3125	2.50	B290600	B290600A	211671	213225
0.290	0.750	0.3125	2.50	B290750	B290750A	211674	213228
0.290	0.900	0.3125	2.50	B290900	B290900A	211677	213231
0.290	1.000	0.3125	2.50	B2901000	B2901000A	211647	213201
0.290	1.100	0.3125	2.50	B2901100	B2901100A	211650	213204
0.290	1.250	0.3125	2.50	B2901250	B2901250A	211653	213207
0.290	1.350	0.3125	2.50	B2901350	B2901350A	211656	213210
0.290	1.500	0.3125	2.50	B2901500	B2901500A	211659	213213
0.290	1.600	0.3125	3.00	B2901600	B2901600A	211662	213216
0.290	1.750	0.3125	3.00	B2901750	B2901750A	211665	213219
0.320	0.500	0.375	2.50	B320500	B320500A	211707	213261
0.320	0.600	0.375	2.50	B320600	B320600A	211710	213264
0.320	0.750	0.375	2.50	B320750	B320750A	211713	213267
0.320	0.900	0.375	2.50	B320900	B320900A	211716	213270
0.320	1.000	0.375	2.50	B3201000	B3201000A	211680	213234
0.320	1.100	0.375	2.50	B3201100	B3201100A	211683	213237
0.320	1.250	0.375	2.50	B3201250	B3201250A	211686	213240
0.320	1.500	0.375	2.50	B3201500	B3201500A	211689	213243
0.320	1.600	0.375	3.00	B3201600	B3201600A	211692	213246
0.320	1.800	0.375	3.00	B3201800	B3201800A	211695	213249
0.320	2.000	0.375	4.00	B3202000	B3202000A	211698	213252
0.320	2.500	0.375	4.00	B3202500	B3202500A	211701	213255
0.320	3.000	0.375	4.00	B3203000	B3203000A	211704	213258

"A" MIN BORE	"B" MAX DEPTH	"S" SHANK DIA.	OAL	ORDER #		EDP #	
				UNCOATED	AITiN+	UNCOATED	AITiN+
0.360	0.500	0.375	2.50	B360500	B360500A	211746	213300
0.360	0.600	0.375	2.50	B360600	B360600A	211749	213303
0.360	0.750	0.375	2.50	B360750	B360750A	211752	213306
0.360	0.900	0.375	2.50	B360900	B360900A	211755	213309
0.360	1.000	0.375	2.50	B3601000	B3601000A	211719	213273
0.360	1.150	0.375	2.50	B3601150	B3601150A	211722	213276
0.360	1.250	0.375	2.50	B3601250	B3601250A	211725	213279
0.360	1.500	0.375	2.50	B3601500	B3601500A	211728	213282
0.360	1.600	0.375	3.00	B3601600	B3601600A	211731	213285
0.360	1.800	0.375	3.00	B3601800	B3601800A	211734	213288
0.360	2.000	0.375	4.00	B3602000	B3602000A	211737	213291
0.360	2.500	0.375	4.00	B3602500	B3602500A	211740	213294
0.360	3.000	0.375	4.00	B3603000	B3603000A	211743	213297
0.490	0.750	0.500	3.00	B490750	B490750A	211791	213345
0.490	1.000	0.500	3.00	B4901000	B4901000A	211758	213312
0.490	1.250	0.500	3.00	B4901250	B4901250A	211761	213315
0.490	1.500	0.500	3.00	B4901500	B4901500A	211764	213318
0.490	2.000	0.500	4.00	B4902000	B4902000A	211767	213321
0.490	2.500	0.500	4.00	B4902500	B4902500A	211770	213324
0.490	2.600	0.500	4.00	B4902600	B4902600A	211773	213327
0.490	2.750	0.500	4.00	B4902750	B4902750A	211776	213330
0.490	3.000	0.500	6.00	B4903000	B4903000A	211779	213333
0.490	3.500	0.500	6.00	B4903500	B4903500A	211782	213336
0.490	4.000	0.500	6.00	B4904000	B4904000A	211785	213339
0.490	4.500	0.500	6.00	B4904500	B4904500A	211788	213342

[Go to Single Point Tools Overview](#)

RADIUS BORING BARS - SOLID CARBIDE

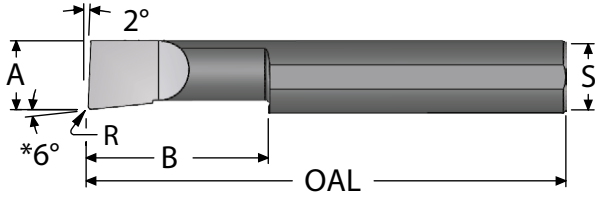

- ALTiN+ coating extends tool life
- Polished flute face for optimum performance
- Corner radius ensures strength and better surface finish

"A" MIN BORE	"B" MAX DEPTH	"R" RADIUS ±0.001	"S" SHANK DIA.	OAL	ORDER #		EDP #	
					UNCOATED	AITiN+	UNCOATED	AITiN+
0.050	0.150	0.004	0.125	1.50	B050150R	B050150RA	213348	214134
0.050	0.200	0.004	0.125	1.50	B050200R	B050200RA	213351	214137
0.050	0.300	0.004	0.125	1.50	B050300R	B050300RA	213354	214140
0.050	0.400	0.004	0.125	1.50	B050400R	B050400RA	213357	214143
0.060	0.150	0.004	0.125	1.50	B060150R	B060150RA	213360	214146
0.060	0.200	0.004	0.125	1.50	B060200R	B060200RA	213363	214149
0.060	0.300	0.004	0.125	1.50	B060300R	B060300RA	213366	214152
0.060	0.400	0.004	0.125	1.50	B060400R	B060400RA	213369	214155
0.060	0.500	0.004	0.125	1.50	B060500R	B060500RA	213372	214158
0.080	0.150	0.004	0.125	1.50	B080150R	B080150RA	213375	214161
0.080	0.200	0.004	0.125	1.50	B080200R	B080200RA	213378	214164
0.080	0.300	0.004	0.125	1.50	B080300R	B080300RA	213381	214167
0.080	0.400	0.004	0.125	1.50	B080400R	B080400RA	213384	214170
0.080	0.500	0.004	0.125	1.50	B080500R	B080500RA	213387	214173
0.080	0.600	0.004	0.125	1.50	B080600R	B080600RA	213390	214176
0.100	0.150	0.004	0.125	1.50	B100150R	B100150RA	213393	214179
0.100	0.200	0.004	0.125	1.50	B100200R	B100200RA	213396	214182
0.100	0.300	0.004	0.125	1.50	B100300R	B100300RA	213399	214185
0.100	0.400	0.004	0.125	1.50	B100400R	B100400RA	213402	214188
0.100	0.500	0.004	0.125	1.50	B100500R	B100500RA	213405	214191
0.100	0.600	0.004	0.125	1.50	B100600R	B100600RA	213408	214194
0.100	0.700	0.004	0.125	1.50	B100700R	B100700RA	213411	214197
0.110	0.150	0.004	0.125	1.50	B110150R	B110150RA	213414	214200
0.110	0.200	0.004	0.125	1.50	B110200R	B110200RA	213417	214203
0.110	0.300	0.004	0.125	1.50	B110300R	B110300RA	213420	214206
0.110	0.400	0.004	0.125	1.50	B110400R	B110400RA	213423	214209
0.110	0.500	0.004	0.125	1.50	B110500R	B110500RA	213426	214212
0.110	0.600	0.004	0.125	1.50	B110600R	B110600RA	213429	214215
0.110	0.700	0.004	0.125	1.50	B110700R	B110700RA	213432	214218
0.120	0.250	0.0065	0.1875	2.00	B120250R	B120250RA	213435	214221
0.120	0.350	0.0065	0.1875	2.00	B120350R	B120350RA	213438	214224
0.120	0.500	0.0065	0.1875	2.00	B120500R	B120500RA	213441	214227
0.120	0.600	0.0065	0.1875	2.00	B120600R	B120600RA	213444	214230
0.120	0.700	0.0065	0.1875	2.00	B120700R	B120700RA	213447	214233
0.120	0.800	0.0065	0.1875	2.00	B120800R	B120800RA	213450	214236

"A" MIN BORE	"B" MAX DEPTH	"R" RADIUS ±0.001	"S" SHANK DIA.	OAL	ORDER #		EDP #	
					UNCOATED	AITiN+	UNCOATED	AITiN+
0.140	0.250	0.0065	0.1875	2.00	B140250R	B140250RA	213453	214239
0.140	0.400	0.0065	0.1875	2.00	B140400R	B140400RA	213456	214242
0.140	0.500	0.0065	0.1875	2.00	B140500R	B140500RA	213459	214245
0.140	0.600	0.0065	0.1875	2.00	B140600R	B140600RA	213462	214248
0.140	0.700	0.0065	0.1875	2.00	B140700R	B140700RA	213465	214251
0.140	0.750	0.0065	0.1875	2.00	B140750R	B140750RA	213468	214254
0.140	0.800	0.0065	0.1875	2.00	B140800R	B140800RA	213471	214257
0.160	0.250	0.0065	0.1875	2.00	B160250R	B160250RA	213477	214263
0.160	0.400	0.0065	0.1875	2.00	B160400R	B160400RA	213480	214266
0.160	0.500	0.0065	0.1875	2.00	B160500R	B160500RA	213483	214269
0.160	0.600	0.0065	0.1875	2.00	B160600R	B160600RA	213486	214272
0.160	0.750	0.0065	0.1875	2.00	B160750R	B160750RA	213489	214275
0.160	0.900	0.0065	0.1875	2.00	B160900R	B160900RA	213492	214278
0.160	1.000	0.0065	0.1875	2.00	B1601000R	B1601000RA	213474	214260
0.180	0.350	0.0065	0.250	2.50	B180350R	B180350RA	213507	214293
0.180	0.500	0.0065	0.250	2.50	B180500R	B180500RA	213510	214296
0.180	0.600	0.0065	0.250	2.50	B180600R	B180600RA	213513	214299
0.180	0.750	0.0065	0.250	2.50	B180750R	B180750RA	213516	214302
0.180	0.900	0.0065	0.250	2.50	B180900R	B180900RA	213519	214305
0.180	1.000	0.0065	0.250	2.50	B1801000R	B1801000RA	213495	214281
0.180	1.100	0.0065	0.250	2.50	B1801100R	B1801100RA	213498	214284
0.180	1.250	0.0065	0.250	2.50	B1801250R	B1801250RA	213501	214287
0.180	1.500	0.0065	0.250	2.50	B1801500R	B1801500RA	213504	214290
0.200	0.400	0.0065	0.250	2.50	B200400R	B200400RA	213534	214320
0.200	0.500	0.0065	0.250	2.50	B200500R	B200500RA	213537	214323
0.200	0.600	0.0065	0.250	2.50	B200600R	B200600RA	213540	214326
0.200	0.700	0.0065	0.250	2.50	B200700R	B200700RA	213543	214329
0.200	0.800	0.0065	0.250	2.50	B200800R	B200800RA	213546	214332
0.200	0.900	0.0065	0.250	2.50	B200900R	B200900RA	213549	214335
0.200	1.000	0.0065	0.250	2.50	B2001000R	B2001000RA	213522	214308
0.200	1.100	0.0065	0.250	2.50	B2001100R	B2001100RA	213525	214311
0.200	1.200	0.0065	0.250	2.50	B2001200R	B2001200RA	213528	214314
0.200	1.300	0.0065	0.250	2.50	B2001300R	B2001300RA	213531	214317

* The B050 and the B060 series have 3° side clearance.

[Go to Single Point Tools Overview](#)

RADIUS BORING BARS - SOLID CARBIDE

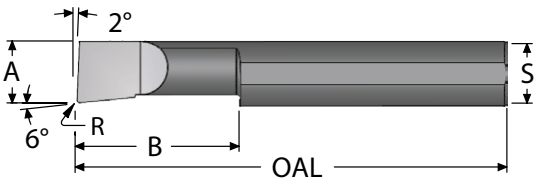

- Elliptically ground neck provides maximum strength
- Made with premium submicron grade carbide
- ALTiN+ coating for higher Surface Feet per Minute

"A" MIN BORE	"B" MAX DEPTH	"R" RADIUS ±0.001	"S" SHANK DIA.	OAL	ORDER #		EDP #	
					UNCOATED	AITIN+	UNCOATED	AITIN+
0.230	0.400	0.0065	0.3125	2.50	B230400R	B230400RA	213576	214362
0.230	0.500	0.0065	0.3125	2.50	B230500R	B230500RA	213579	214365
0.230	0.600	0.0065	0.3125	2.50	B230600R	B230600RA	213582	214368
0.230	0.700	0.0065	0.3125	2.50	B230700R	B230700RA	213585	214371
0.230	0.800	0.0065	0.3125	2.50	B230800R	B230800RA	213588	214374
0.230	0.900	0.0065	0.3125	2.50	B230900R	B230900RA	213591	214377
0.230	1.000	0.0065	0.3125	2.50	B2301000R	B2301000RA	213552	214338
0.230	1.100	0.0065	0.3125	2.50	B2301100R	B2301100RA	213555	214341
0.230	1.150	0.0065	0.3125	2.50	B2301150R	B2301150RA	213558	214344
0.230	1.200	0.0065	0.3125	2.50	B2301200R	B2301200RA	213561	214347
0.230	1.250	0.0065	0.3125	2.50	B2301250R	B2301250RA	213564	214350
0.230	1.400	0.0065	0.3125	2.50	B2301400R	B2301400RA	213567	214353
0.230	1.500	0.0065	0.3125	2.50	B2301500R	B2301500RA	213570	214356
0.230	1.600	0.0065	0.3125	3.00	B2301600R	B2301600RA	213573	214359
0.290	0.500	0.0065	0.3125	2.50	B290500R	B290500RA	213615	214401
0.290	0.600	0.0065	0.3125	2.50	B290600R	B290600RA	213618	214404
0.290	0.750	0.0065	0.3125	2.50	B290750R	B290750RA	213621	214407
0.290	0.900	0.0065	0.3125	2.50	B290900R	B290900RA	213624	214410
0.290	1.000	0.0065	0.3125	2.50	B2901000R	B2901000RA	213594	214380
0.290	1.100	0.0065	0.3125	2.50	B2901100R	B2901100RA	213597	214383
0.290	1.250	0.0065	0.3125	2.50	B2901250R	B2901250RA	213600	214386
0.290	1.350	0.0065	0.3125	2.50	B2901350R	B2901350RA	213603	214389
0.290	1.500	0.0065	0.3125	2.50	B2901500R	B2901500RA	213606	214392
0.290	1.600	0.0065	0.3125	3.00	B2901600R	B2901600RA	213609	214395
0.290	1.750	0.0065	0.3125	3.00	B2901750R	B2901750RA	213612	214398
0.320	0.500	0.0065	0.375	2.50	B320500R	B320500RA	213654	214440
0.320	0.600	0.0065	0.375	2.50	B320600R	B320600RA	213657	214443
0.320	0.750	0.0065	0.375	2.50	B320750R	B320750RA	213660	214446
0.320	0.900	0.0065	0.375	2.50	B320900R	B320900RA	213663	214449
0.320	1.000	0.0065	0.375	2.50	B3201000R	B3201000RA	213627	214413
0.320	1.100	0.0065	0.375	2.50	B3201100R	B3201100RA	213630	214416
0.320	1.250	0.0065	0.375	2.50	B3201250R	B3201250RA	213633	214419
0.320	1.500	0.0065	0.375	2.50	B3201500R	B3201500RA	213636	214422
0.320	1.600	0.0065	0.375	3.00	B3201600R	B3201600RA	213639	214425
0.320	1.800	0.0065	0.375	3.00	B3201800R	B3201800RA	213642	214428
0.320	2.000	0.0065	0.375	4.00	B3202000R	B3202000RA	213645	214431
0.320	2.500	0.0065	0.375	4.00	B3202500R	B3202500RA	213648	214434
0.320	3.000	0.0065	0.375	4.00	B3203000R	B3203000RA	213651	214437

"A" MIN BORE	"B" MAX DEPTH	"R" RADIUS ±0.001	"S" SHANK DIA.	OAL	ORDER #		EDP #	
					UNCOATED	AITIN+	UNCOATED	AITIN+
0.360	0.500	0.0065	0.375	2.50	B360500R	B360500RA	213693	214479
0.360	0.600	0.0065	0.375	2.50	B360600R	B360600RA	213696	214482
0.360	0.750	0.0065	0.375	2.50	B360750R	B360750RA	213699	214485
0.360	0.900	0.0065	0.375	2.50	B360900R	B360900RA	213702	214488
0.360	1.000	0.0065	0.375	2.50	B3601000R	B3601000RA	213666	214452
0.360	1.150	0.0065	0.375	2.50	B3601150R	B3601150RA	213669	214455
0.360	1.250	0.0065	0.375	2.50	B3601250R	B3601250RA	213672	214458
0.360	1.500	0.0065	0.375	2.50	B3601500R	B3601500RA	213675	214461
0.360	1.600	0.0065	0.375	3.00	B3601600R	B3601600RA	213678	214464
0.360	1.800	0.0065	0.375	3.00	B3601800R	B3601800RA	213681	214467
0.360	2.000	0.0065	0.375	4.00	B3602000R	B3602000RA	213684	214470
0.360	2.500	0.0065	0.375	4.00	B3602500R	B3602500RA	213687	214473
0.360	3.000	0.0065	0.375	4.00	B3603000R	B3603000RA	213690	214476
0.490	0.750	0.0065	0.500	3.00	B490750R	B490750RA	213738	214524
0.490	1.000	0.0065	0.500	3.00	B4901000R	B4901000RA	213705	214491
0.490	1.250	0.0065	0.500	3.00	B4901250R	B4901250RA	213708	214494
0.490	1.500	0.0065	0.500	3.00	B4901500R	B4901500RA	213711	214497
0.490	2.000	0.0065	0.500	4.00	B4902000R	B4902000RA	213714	214500
0.490	2.500	0.0065	0.500	4.00	B4902500R	B4902500RA	213717	214503
0.490	2.600	0.0065	0.500	4.00	B4902600R	B4902600RA	213720	214506
0.490	2.750	0.0065	0.500	4.00	B4902750R	B4902750RA	213723	214509
0.490	3.000	0.0065	0.500	6.00	B4903000R	B4903000RA	213726	214512
0.490	3.500	0.0065	0.500	6.00	B4903500R	B4903500RA	213729	214515
0.490	4.000	0.0065	0.500	6.00	B4904000R	B4904000RA	213732	214518
0.490	4.500	0.0065	0.500	6.00	B4904500R	B4904500RA	213735	214521

[Go to Single Point Tools Overview](#)

BORING BARS - LEFT HAND - SOLID CARBIDE

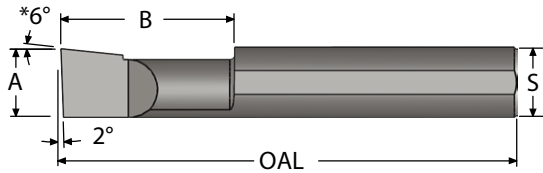

- ALTiN+ coating provides better surface finish
- Elliptically ground neck provides maximum strength
- Made with premium submicron grade carbide

"A" MIN BORE	"B" MAX DEPTH	"S" SHANK DIA.	OAL	ORDER #		EDP #	
				UNCOATED	AITIN+	UNCOATED	AITIN+
0.050	0.150	0.125	1.50	LHB050150	LHB050150A	211794	215001
0.050	0.200	0.125	1.50	LHB050200	LHB050200A	211797	215004
0.050	0.300	0.125	1.50	LHB050300	LHB050300A	211800	215007
0.050	0.400	0.125	1.50	LHB050400	LHB050400A	211803	215010
0.060	0.150	0.125	1.50	LHB060150	LHB060150A	211806	215013
0.060	0.200	0.125	1.50	LHB060200	LHB060200A	211809	215016
0.060	0.300	0.125	1.50	LHB060300	LHB060300A	211812	215019
0.060	0.400	0.125	1.50	LHB060400	LHB060400A	211815	215022
0.060	0.500	0.125	1.50	LHB060500	LHB060500A	211818	215025
0.080	0.150	0.125	1.50	LHB080150	LHB080150A	211821	215028
0.080	0.200	0.125	1.50	LHB080200	LHB080200A	211824	215031
0.080	0.300	0.125	1.50	LHB080300	LHB080300A	211827	215034
0.080	0.400	0.125	1.50	LHB080400	LHB080400A	211830	215037
0.080	0.500	0.125	1.50	LHB080500	LHB080500A	211833	215040
0.080	0.600	0.125	1.50	LHB080600	LHB080600A	211836	215043
0.100	0.150	0.125	1.50	LHB100150	LHB100150A	211839	215046
0.100	0.200	0.125	1.50	LHB100200	LHB100200A	211842	215049
0.100	0.300	0.125	1.50	LHB100300	LHB100300A	211845	215052
0.100	0.400	0.125	1.50	LHB100400	LHB100400A	211848	215055
0.100	0.500	0.125	1.50	LHB100500	LHB100500A	211851	215058
0.100	0.600	0.125	1.50	LHB100600	LHB100600A	211854	215061
0.100	0.700	0.125	1.50	LHB100700	LHB100700A	211857	215064
0.110	0.150	0.125	1.50	LHB110150	LHB110150A	211860	215067
0.110	0.200	0.125	1.50	LHB110200	LHB110200A	211863	215070
0.110	0.300	0.125	1.50	LHB110300	LHB110300A	211866	215073
0.110	0.400	0.125	1.50	LHB110400	LHB110400A	211869	215076
0.110	0.500	0.125	1.50	LHB110500	LHB110500A	211872	215079
0.110	0.600	0.125	1.50	LHB110600	LHB110600A	211875	215082
0.110	0.700	0.125	1.50	LHB110700	LHB110700A	211878	215085
0.120	0.250	0.1875	2.00	LHB120250	LHB120250A	211881	215088
0.120	0.350	0.1875	2.00	LHB120350	LHB120350A	211884	215091
0.120	0.500	0.1875	2.00	LHB120500	LHB120500A	211887	215094
0.120	0.600	0.1875	2.00	LHB120600	LHB120600A	211890	215097
0.120	0.700	0.1875	2.00	LHB120700	LHB120700A	211893	215100
0.120	0.800	0.1875	2.00	LHB120800	LHB120800A	211896	215103

"A" MIN BORE	"B" MAX DEPTH	"S" SHANK DIA.	OAL	ORDER #		EDP #	
				UNCOATED	AITIN+	UNCOATED	AITIN+
0.140	0.250	0.1875	2.00	LHB140250	LHB140250A	211899	215106
0.140	0.400	0.1875	2.00	LHB140400	LHB140400A	211902	215109
0.140	0.500	0.1875	2.00	LHB140500	LHB140500A	211905	215112
0.140	0.600	0.1875	2.00	LHB140600	LHB140600A	211908	215115
0.140	0.700	0.1875	2.00	LHB140700	LHB140700A	211911	215118
0.140	0.750	0.1875	2.00	LHB140750	LHB140750A	211914	215121
0.140	0.800	0.1875	2.00	LHB140800	LHB140800A	211917	215124
0.160	0.250	0.1875	2.00	LHB160250	LHB160250A	211923	215130
0.160	0.400	0.1875	2.00	LHB160400	LHB160400A	211926	215133
0.160	0.500	0.1875	2.00	LHB160500	LHB160500A	211929	215136
0.160	0.600	0.1875	2.00	LHB160600	LHB160600A	211932	215139
0.160	0.750	0.1875	2.00	LHB160750	LHB160750A	211935	215142
0.160	0.900	0.1875	2.00	LHB160900	LHB160900A	211938	215145
0.160	1.000	0.1875	2.00	LHB1601000	LHB1601000A	211920	215127
0.180	0.350	0.250	2.50	LHB180350	LHB180350A	211947	215154
0.180	0.500	0.250	2.50	LHB180500	LHB180500A	211950	215157
0.180	0.600	0.250	2.50	LHB180600	LHB180600A	211953	215160
0.180	0.750	0.250	2.50	LHB180750	LHB180750A	211956	215163
0.180	0.900	0.250	2.50	LHB180900	LHB180900A	211959	215166
0.180	1.000	0.250	2.50	LHB1801000	LHB1801000A	211941	215148
0.180	1.100	0.250	2.50	LHB1801100	LHB1801100A	211944	215151
0.200	0.400	0.250	2.50	LHB200400	LHB200400A	211974	215181
0.200	0.500	0.250	2.50	LHB200500	LHB200500A	211977	215184
0.200	0.600	0.250	2.50	LHB200600	LHB200600A	211980	215187
0.200	0.700	0.250	2.50	LHB200700	LHB200700A	211983	215190
0.200	0.800	0.250	2.50	LHB200800	LHB200800A	211986	215193
0.200	0.900	0.250	2.50	LHB200900	LHB200900A	211989	215196
0.200	1.000	0.250	2.50	LHB2001000	LHB2001000A	211962	215169
0.200	1.100	0.250	2.50	LHB2001100	LHB2001100A	211965	215172
0.200	1.200	0.250	2.50	LHB2001200	LHB2001200A	211968	215175
0.200	1.300	0.250	2.50	LHB2001300	LHB2001300A	211971	215178

* The LHB050 and the LHB060 series have 3° side clearance.

[Go to Single Point Tools Overview](#)

BORING BARS - LEFT HAND - SOLID CARBIDE

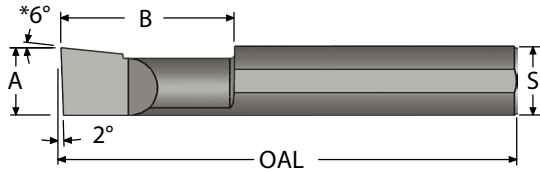

- ALTiN+ coating extends tool life
- Polished flute face for optimum performance
- Precision ground shank flat guarantees tool orientation

"A" MIN BORE	"B" MAX DEPTH	"S" SHANK DIA.	OAL	ORDER #		EDP #	
				UNCOATED	AITiN+	UNCOATED	AITiN+
0.230	0.400	0.3125	2.50	LHB230400	LHB230400A	212013	215220
0.230	0.500	0.3125	2.50	LHB230500	LHB230500A	212016	215223
0.230	0.600	0.3125	2.50	LHB230600	LHB230600A	212019	215226
0.230	0.700	0.3125	2.50	LHB230700	LHB230700A	212022	215229
0.230	0.800	0.3125	2.50	LHB230800	LHB230800A	212025	215232
0.230	0.900	0.3125	2.50	LHB230900	LHB230900A	212028	215235
0.230	1.000	0.3125	2.50	LHB2301000	LHB2301000A	211992	215199
0.230	1.150	0.3125	2.50	LHB2301150	LHB2301150A	211995	215202
0.230	1.200	0.3125	2.50	LHB2301200	LHB2301200A	211998	215205
0.230	1.250	0.3125	2.50	LHB2301250	LHB2301250A	212001	215208
0.230	1.400	0.3125	2.50	LHB2301400	LHB2301400A	212004	215211
0.230	1.500	0.3125	2.50	LHB2301500	LHB2301500A	212007	215214
0.230	1.600	0.3125	3.00	LHB2301600	LHB2301600A	212010	215217
0.290	0.500	0.3125	2.50	LHB290500	LHB290500A	212052	215259
0.290	0.600	0.3125	2.50	LHB290600	LHB290600A	212055	215262
0.290	0.750	0.3125	2.50	LHB290750	LHB290750A	212058	215265
0.290	0.900	0.3125	2.50	LHB290900	LHB290900A	212061	215268
0.290	1.000	0.3125	2.50	LHB2901000	LHB2901000A	212031	215238
0.290	1.100	0.3125	2.50	LHB2901100	LHB2901100A	212034	215241
0.290	1.250	0.3125	2.50	LHB2901250	LHB2901250A	212037	215244
0.290	1.350	0.3125	2.50	LHB2901350	LHB2901350A	212040	215247
0.290	1.500	0.3125	2.50	LHB2901500	LHB2901500A	212043	215250
0.290	1.600	0.3125	3.00	LHB2901600	LHB2901600A	212046	215253
0.290	1.750	0.3125	3.00	LHB2901750	LHB2901750A	212049	215256
0.320	0.500	0.375	2.50	LHB320500	LHB320500A	212091	215298
0.320	0.600	0.375	2.50	LHB320600	LHB320600A	212094	215301
0.320	0.750	0.375	2.50	LHB320750	LHB320750A	212097	215304
0.320	0.900	0.375	2.50	LHB320900	LHB320900A	212100	215307
0.320	1.000	0.375	2.50	LHB3201000	LHB3201000A	212064	215271
0.320	1.100	0.375	2.50	LHB3201100	LHB3201100A	212067	215274
0.320	1.250	0.375	2.50	LHB3201250	LHB3201250A	212070	215277
0.320	1.500	0.375	2.50	LHB3201500	LHB3201500A	212073	215280
0.320	1.600	0.375	3.00	LHB3201600	LHB3201600A	212076	215283
0.320	1.800	0.375	3.00	LHB3201800	LHB3201800A	212079	215286
0.320	2.000	0.375	4.00	LHB3202000	LHB3202000A	212082	215289
0.320	2.500	0.375	4.00	LHB3202500	LHB3202500A	212085	215292
0.320	3.000	0.375	4.00	LHB3203000	LHB3203000A	212088	215295

"A" MIN BORE	"B" MAX DEPTH	"S" SHANK DIA.	OAL	ORDER #		EDP #	
				UNCOATED	AITiN+	UNCOATED	AITiN+
0.360	0.500	0.375	2.50	LHB360500	LHB360500A	212130	215337
0.360	0.600	0.375	2.50	LHB360600	LHB360600A	212133	215340
0.360	0.750	0.375	2.50	LHB360750	LHB360750A	212136	215343
0.360	0.900	0.375	2.50	LHB360900	LHB360900A	212139	215346
0.360	1.000	0.375	2.50	LHB3601000	LHB3601000A	212103	215310
0.360	1.150	0.375	2.50	LHB3601150	LHB3601150A	212106	215313
0.360	1.250	0.375	2.50	LHB3601250	LHB3601250A	212109	215316
0.360	1.500	0.375	2.50	LHB3601500	LHB3601500A	212112	215319
0.360	1.600	0.375	3.00	LHB3601600	LHB3601600A	212115	215322
0.360	1.800	0.375	3.00	LHB3601800	LHB3601800A	212118	215325
0.360	2.000	0.375	4.00	LHB3602000	LHB3602000A	212121	215328
0.360	2.500	0.375	4.00	LHB3602500	LHB3602500A	212124	215331
0.360	3.000	0.375	4.00	LHB3603000	LHB3603000A	212127	215334
0.490	0.750	0.500	3.00	LHB490750	LHB490750A	212175	215382
0.490	1.000	0.500	3.00	LHB4901000	LHB4901000A	212142	215349
0.490	1.250	0.500	3.00	LHB4901250	LHB4901250A	212145	215352
0.490	1.500	0.500	3.00	LHB4901500	LHB4901500A	212148	215355
0.490	2.000	0.500	4.00	LHB4902000	LHB4902000A	212151	215358
0.490	2.500	0.500	4.00	LHB4902500	LHB4902500A	212154	215361
0.490	2.600	0.500	4.00	LHB4902600	LHB4902600A	212157	215364
0.490	2.750	0.500	4.00	LHB4902750	LHB4902750A	212160	215367
0.490	3.000	0.500	6.00	LHB4903000	LHB4903000A	212163	215370
0.490	3.500	0.500	6.00	LHB4903500	LHB4903500A	212166	215373
0.490	4.000	0.500	6.00	LHB4904000	LHB4904000A	212169	215376
0.490	4.500	0.500	6.00	LHB4904500	LHB4904500A	212172	215379

[Go to Single Point Tools Overview](#)

BORING BARS - CBN TIPPED - PCD TIPPED

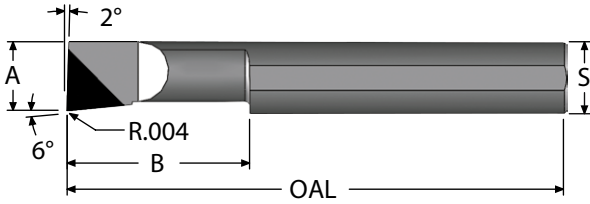

- PCD for abrasive non-ferrous materials
- CBN for hard ferrous metal - 45Rc plus
- Faster speeds and feeds
- Maintains tighter tolerances
- Solid carbide body for maximum rigidity

"A" MIN BORE	"B" MAX DEPTH	"S" SHANK DIA.	OAL	ORDER #		EDP #	
				PCD	CBN	PCD	CBN
0.120	0.250	0.1875	2.00	PCD-B120250	CBN-B120250	226001	226262
0.120	0.350	0.1875	2.00	PCD-B120350	CBN-B120350	226004	226265
0.120	0.500	0.1875	2.00	PCD-B120500	CBN-B120500	226007	226268
0.120	0.600	0.1875	2.00	PCD-B120600	CBN-B120600	226010	226271
0.120	0.700	0.1875	2.00	PCD-B120700	CBN-B120700	226013	226274
0.120	0.800	0.1875	2.00	PCD-B120800	CBN-B120800	226016	226277
0.140	0.250	0.1875	2.00	PCD-B140250	CBN-B140250	226019	226280
0.140	0.400	0.1875	2.00	PCD-B140400	CBN-B140400	226022	226283
0.140	0.500	0.1875	2.00	PCD-B140500	CBN-B140500	226025	226286
0.140	0.600	0.1875	2.00	PCD-B140600	CBN-B140600	226028	226289
0.140	0.700	0.1875	2.00	PCD-B140700	CBN-B140700	226031	226292
0.140	0.750	0.1875	2.00	PCD-B140750	CBN-B140750	226034	226295
0.140	0.800	0.1875	2.00	PCD-B140800	CBN-B140800	226037	226298
0.160	0.250	0.1875	2.00	PCD-B160250	CBN-B160250	226043	226304
0.160	0.400	0.1875	2.00	PCD-B160400	CBN-B160400	226046	226307
0.160	0.500	0.1875	2.00	PCD-B160500	CBN-B160500	226049	226310
0.160	0.600	0.1875	2.00	PCD-B160600	CBN-B160600	226052	226313
0.160	0.750	0.1875	2.00	PCD-B160750	CBN-B160750	226055	226316
0.160	0.900	0.1875	2.00	PCD-B160900	CBN-B160900	226058	226319
0.160	1.000	0.1875	2.00	PCD-B1601000	CBN-B1601000	226040	226301
0.180	0.350	0.250	2.50	PCD-B180350	CBN-B180350	226067	226328
0.180	0.500	0.250	2.50	PCD-B180500	CBN-B180500	226070	226331
0.180	0.600	0.250	2.50	PCD-B180600	CBN-B180600	226073	226334
0.180	0.750	0.250	2.50	PCD-B180750	CBN-B180750	226076	226337
0.180	0.900	0.250	2.50	PCD-B180900	CBN-B180900	226079	226340
0.180	1.000	0.250	2.50	PCD-B1801000	CBN-B1801000	226061	226322
0.180	1.100	0.250	2.50	PCD-B1801100	CBN-B1801100	226064	226325
0.200	0.400	0.250	2.50	PCD-B200400	CBN-B200400	226094	226355
0.200	0.500	0.250	2.50	PCD-B200500	CBN-B200500	226097	226358
0.200	0.600	0.250	2.50	PCD-B200600	CBN-B200600	226100	226361
0.200	0.700	0.250	2.50	PCD-B200700	CBN-B200700	226103	226364
0.200	0.800	0.250	2.50	PCD-B200800	CBN-B200800	226106	226367
0.200	0.900	0.250	2.50	PCD-B200900	CBN-B200900	226109	226370
0.200	1.000	0.250	2.50	PCD-B2001000	CBN-B2001000	226082	226343
0.200	1.100	0.250	2.50	PCD-B2001100	CBN-B2001100	226085	226346
0.200	1.200	0.250	2.50	PCD-B2001200	CBN-B2001200	226088	226349
0.200	1.300	0.250	2.50	PCD-B2001300	CBN-B2001300	226091	226352
0.230	0.400	0.3125	2.50	PCD-B230400	CBN-B230400	226133	226394
0.230	0.500	0.3125	2.50	PCD-B230500	CBN-B230500	226136	226397
0.230	0.600	0.3125	2.50	PCD-B230600	CBN-B230600	226139	226400
0.230	0.700	0.3125	2.50	PCD-B230700	CBN-B230700	226142	226403
0.230	0.800	0.3125	2.50	PCD-B230800	CBN-B230800	226145	226406
0.230	0.900	0.3125	2.50	PCD-B230900	CBN-B230900	226148	226409

[Go to Single Point Tools Overview](#)

BORING BARS - CBN TIPPED - PCD TIPPED

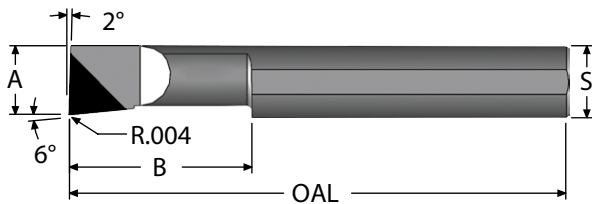

- PCD for abrasive non-ferrous materials
- CBN for hard ferrous metal - 45Rc plus
- Faster speeds and feeds
- Maintains tighter tolerances
- Solid carbide body for maximum rigidity

"A" MIN BORE	"B" MAX DEPTH	"S" SHANK DIA.	OAL	ORDER #		EDP #	
				PCD	CBN	PCD	CBN
0.230	1.000	0.3125	2.50	PCD-B2301000	CBN-B2301000	226112	226373
0.230	1.150	0.3125	2.50	PCD-B2301150	CBN-B2301150	226115	226376
0.230	1.200	0.3125	2.50	PCD-B2301200	CBN-B2301200	226118	226379
0.230	1.250	0.3125	2.50	PCD-B2301250	CBN-B2301250	226121	226382
0.230	1.400	0.3125	2.50	PCD-B2301400	CBN-B2301400	226124	226385
0.230	1.500	0.3125	2.50	PCD-B2301500	CBN-B2301500	226127	226388
0.230	1.600	0.3125	2.50	PCD-B2301600	CBN-B2301600	226130	226391
0.290	0.500	0.3125	2.50	PCD-B290500	CBN-B290500	226172	226433
0.290	0.600	0.3125	2.50	PCD-B290600	CBN-B290600	226175	226436
0.290	0.750	0.3125	2.50	PCD-B290750	CBN-B290750	226178	226439
0.290	0.900	0.3125	2.50	PCD-B290900	CBN-B290900	226181	226442
0.290	1.000	0.3125	2.50	PCD-B2901000	CBN-B2901000	226151	226412
0.290	1.100	0.3125	2.50	PCD-B2901100	CBN-B2901100	226154	226415
0.290	1.250	0.3125	2.50	PCD-B2901250	CBN-B2901250	226157	226418
0.290	1.350	0.3125	2.50	PCD-B2901350	CBN-B2901350	226160	226421
0.290	1.500	0.3125	2.50	PCD-B2901500	CBN-B2901500	226163	226424
0.290	1.600	0.3125	2.50	PCD-B2901600	CBN-B2901600	226166	226427
0.290	1.750	0.3125	2.50	PCD-B2901750	CBN-B2901750	226169	226430
0.320	0.500	0.375	2.50	PCD-B320500	CBN-B320500	226211	226472
0.320	0.600	0.375	2.50	PCD-B320600	CBN-B320600	226214	226475
0.320	0.750	0.375	2.50	PCD-B320750	CBN-B320750	226217	226478
0.320	0.900	0.375	2.50	PCD-B320900	CBN-B320900	226220	226481
0.320	1.000	0.375	2.50	PCD-B3201000	CBN-B3201000	226184	226445
0.320	1.100	0.375	2.50	PCD-B3201100	CBN-B3201100	226187	226448
0.320	1.250	0.375	2.50	PCD-B3201250	CBN-B3201250	226190	226451
0.320	1.500	0.375	2.50	PCD-B3201500	CBN-B3201500	226193	226454
0.320	1.600	0.375	2.50	PCD-B3201600	CBN-B3201600	226196	226457
0.320	1.800	0.375	2.50	PCD-B3201800	CBN-B3201800	226199	226460
0.320	2.000	0.375	4.00	PCD-B3202000	CBN-B3202000	226202	226463
0.320	2.500	0.375	4.00	PCD-B3202500	CBN-B3202500	226205	226466
0.320	3.000	0.375	4.00	PCD-B3203000	CBN-B3203000	226208	226469
0.360	0.500	0.375	2.50	PCD-B360500	CBN-B360500	226250	216511
0.360	0.600	0.375	2.50	PCD-B360600	CBN-B360600	226253	216514
0.360	0.750	0.375	2.50	PCD-B360750	CBN-B360750	226256	216517
0.360	0.900	0.375	2.50	PCD-B360900	CBN-B360900	226259	216520
0.360	1.000	0.375	2.50	PCD-B3601000	CBN-B3601000	226223	226484
0.360	1.150	0.375	2.50	PCD-B3601150	CBN-B3601150	226226	226487
0.360	1.250	0.375	2.50	PCD-B3601250	CBN-B3601250	226229	226490
0.360	1.500	0.375	2.50	PCD-B3601500	CBN-B3601500	226232	226493
0.360	1.600	0.375	2.50	PCD-B3601600	CBN-B3601600	226235	226496
0.360	1.800	0.375	2.50	PCD-B3601800	CBN-B3601800	226238	226499
0.360	2.000	0.375	4.00	PCD-B3602000	CBN-B3602000	226241	226502
0.360	2.500	0.375	4.00	PCD-B3602500	CBN-B3602500	226244	226505
0.360	3.000	0.375	4.00	PCD-B3603000	CBN-B3603000	226247	226508

[Go to Single Point Tools Overview](#)

BORING BARS - HELICAL - SOLID CARBIDE

- Positive high shear tool design reduces cutting force
- ALTiN+ coating helps extend tool life
- Stocked in both uncoated and ALTiN+ coating
- Made with premium submicron grade carbide

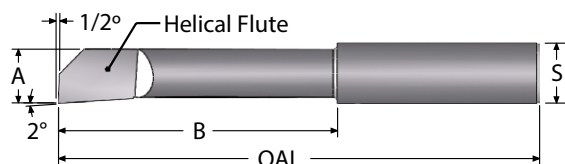

**HELICAL BACK RAKE
WITHOUT FLAT**

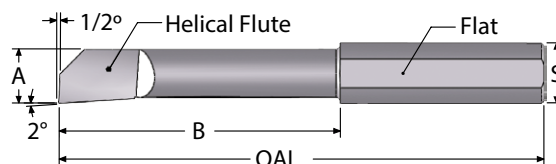

**HELICAL BACK RAKE
WITH FLAT**

"A" MIN BORE	"B" MAX DEPTH	"S" SHANK DIA.	OAL	ORDER #		EDP #	
				UNCOATED	AITiN+	UNCOATED	AITiN+
0.025	0.093	0.125	1.50	HB25	HB25A	215916	216192
0.027	0.125	0.125	1.50	HB27	HB27A	215922	216198
0.031	0.156	0.125	1.50	HB31	HB31A	215928	216204
0.031	0.187	0.125	1.50	HB31L	HB31LA	215934	216210
0.036	0.156	0.125	1.50	HB36	HB36A	215940	216216
0.036	0.250	0.125	1.50	HB36L	HB36LA	215946	216222
0.042	0.250	0.125	1.50	HB42	HB42A	215952	216228
0.042	0.312	0.125	1.50	HB42L	HB42LA	215958	216234
0.052	0.312	0.125	1.50	HB52	HB52A	215964	216240
0.057	0.312	0.125	1.50	HB57	HB57A	215970	216246
0.060	0.375	0.125	1.50	HB60	HB60A	215976	216252
0.060	0.500	0.125	1.50	HB60L	HB60LA	215982	216258
0.070	0.437	0.125	1.50	HB70	HB70A	215988	216264
0.080	0.500	0.125	1.50	HB80	HB80A	215994	216270
0.085	0.500	0.125	1.50	HB85	HB85A	216000	216276
0.090	0.500	0.125	1.50	HB90	HB90A	216006	216282
0.090	0.625	0.125	1.50	HB90L	HB90LA	216012	216288
0.100	0.562	0.125	1.50	HB100	HB100A	215880	216156
0.100	0.625	0.125	2.00	HB100L	HB100LA	215886	216162
0.110	0.562	0.125	1.50	HB110	HB110A	215892	216168
0.110	0.625	0.125	2.00	HB110L	HB110LA	215898	216174
0.115	0.625	0.125	1.50	HB120	HB120A	215904	216180
0.115	0.625	0.125	2.00	HB120L	HB120LA	215910	216186

"A" MIN BORE	"B" MAX DEPTH	"S" SHANK DIA.	OAL	ORDER #		EDP #	
				UNCOATED	AITiN+	UNCOATED	AITiN+
0.025	0.093	0.125	1.50	HB25F	HB25FA	215919	216195
0.027	0.125	0.125	1.50	HB27F	HB27FA	215925	216201
0.031	0.156	0.125	1.50	HB31F	HB31FA	215931	216207
0.031	0.187	0.125	1.50	HB31LF	HB31LFA	215937	216213
0.036	0.156	0.125	1.50	HB36F	HB36FA	215943	216219
0.036	0.250	0.125	1.50	HB36LF	HB36LFA	215949	216225
0.042	0.250	0.125	1.50	HB42F	HB42FA	215955	216231
0.042	0.312	0.125	1.50	HB42LF	HB42LFA	215961	216237
0.052	0.312	0.125	1.50	HB52F	HB52FA	215967	216243
0.057	0.312	0.125	1.50	HB57F	HB57FA	215973	216249
0.060	0.375	0.125	1.50	HB60F	HB60FA	215979	216255
0.060	0.500	0.125	1.50	HB60LF	HB60LFA	215985	216261
0.070	0.437	0.125	1.50	HB70F	HB70FA	215991	216267
0.080	0.500	0.125	1.50	HB80F	HB80FA	215997	216273
0.085	0.500	0.125	1.50	HB85F	HB85FA	216003	216279
0.090	0.500	0.125	1.50	HB90F	HB90FA	216009	216285
0.090	0.625	0.125	1.50	HB90LF	HB90LFA	216015	216291
0.100	0.562	0.125	1.50	HB100F	HB100FA	215883	216159
0.100	0.625	0.125	2.00	HB100LF	HB100LFA	215889	216165
0.110	0.562	0.125	1.50	HB110F	HB110FA	215895	216171
0.110	0.625	0.125	2.00	HB110LF	HB110LFA	215901	216177
0.120	0.625	0.125	1.50	HB120F	HB120FA	215907	216183
0.120	0.625	0.125	2.00	HB120LF	HB120LFA	215913	216189

[Go to Single Point Tools Overview](#)

BORING BARS - HELICAL - SOLID CARBIDE

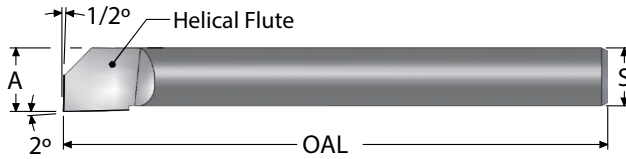

- Bar features an adjustable max bore depth
- ALTiN+ coating provides better surface finish
- Positive high shear tool design reduces cutting force
- Made with premium submicron grade carbide

HELICAL BACK RAKE

"A" MIN BORE	"S" SHANK DIA.	OAL	ORDER #		EDP #	
			UNCOATED	AITiN+	UNCOATED	AITiN+
0.130	0.1093	1.50	HB135	HB135A	215736	215832
0.145	0.1250	1.50	HB150	HB150A	215739	215835
0.145	0.1250	2.50	HB150L	HB150LA	215742	215838
0.174	0.1562	1.50	HB180	HB180A	215745	215841
0.174	0.1562	2.00	HB180L	HB180LA	215751	215847
0.174	0.1562	3.00	HB180EL	HB180ELA	215748	215844
0.205	0.1875	1.50	HB210	HB210A	215754	215850
0.205	0.1875	3.00	HB210L	HB210LA	215757	215853
0.235	0.2187	1.50	HB240	HB240A	215760	215856
0.235	0.2187	3.00	HB240L	HB240LA	215763	215859
0.284	0.2500	2.50	HB300	HB300A	215766	215862
0.284	0.2500	3.50	HB300L	HB300LA	215769	215865
0.345	0.3125	3.00	HB360	HB360A	215772	215868
0.345	0.3125	5.00	HB360L	HB360LA	215775	215871
0.470	0.4375	3.00	HB480	HB480A	215778	215874
0.470	0.4375	6.00	HB480L	HB480LA	215781	215877

THREAD MILLS

SINGLE POINT TOOLS
BORING

INDEXABLE TOOLS

PORT - CAVITY

SPECIALTY

[Go to Single Point Tools Overview](#)

BORING BARS - HELICAL - SOLID CARBIDE

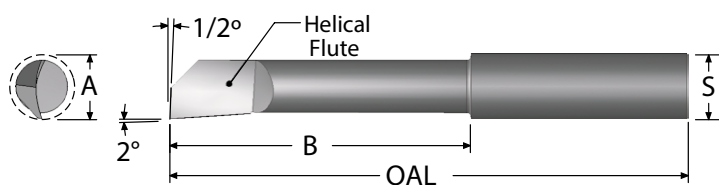

“A” minimum bore diameter refers to the size of the hole that is produced when the tools are rotated on centerline. These tools are designed to be used for both mill and lathe applications.

"A" MIN BORE	"B" MAX DEPTH	"S" SHANK DIA.	OAL	ORDER #		EDP #	
				UNCOATED	ALTiN+	UNCOATED	ALTiN+
0.020	0.062	0.125	1.50	HB020062	HB020062A	216294	216570
0.025	0.062	0.125	1.50	HB025062	HB025062A	216297	216573
0.025	0.125	0.125	1.50	HB025125	HB025125A	216300	216576
0.030	0.125	0.125	1.50	HB030125	HB030125A	216303	216579
0.030	0.187	0.125	1.50	HB030187	HB030187A	216306	216582
0.035	0.125	0.125	1.50	HB035125	HB035125A	216309	216585
0.035	0.187	0.125	1.50	HB035187	HB035187A	216312	216588
0.040	0.187	0.125	1.50	HB040187	HB040187A	216315	216591
0.040	0.250	0.125	1.50	HB040250	HB040250A	216318	216594
0.050	0.312	0.125	1.50	HB050312	HB050312A	216321	216597
0.060	0.375	0.125	1.50	HB060375	HB060375A	216324	216600
0.070	0.437	0.125	1.50	HB070437	HB070437A	216327	216603
0.080	0.500	0.125	1.50	HB080500	HB080500A	216330	216606
0.090	0.500	0.125	1.50	HB090500	HB090500A	216333	216609
0.100	0.562	0.125	1.50	HB100562	HB100562A	216336	216612
0.120	0.625	0.125	1.50	HB120625	HB120625A	216342	216618
0.120	1.000	0.125	2.00	HB1201000	HB1201000A	216339	216615
0.135	0.750	0.1875	2.00	HB135750	HB135750A	216348	216624
0.135	1.000	0.1875	2.00	HB1351000	HB1351000A	216345	216621
0.150	1.000	0.1875	2.00	HB1501000	HB1501000A	216351	216627
0.150	1.250	0.1875	2.00	HB1501250	HB1501250A	216354	216630
0.180	1.000	0.1875	2.00	HB1801000	HB1801000A	216357	216633
0.180	1.250	0.1875	2.50	HB1801250	HB1801250A	216360	216636
0.180	1.500	0.1875	2.50	HB1801500	HB1801500A	216363	216639

"A" MIN BORE	"B" MAX DEPTH	"S" SHANK DIA.	OAL	ORDER #		EDP #	
				UNCOATED	ALTiN+	UNCOATED	ALTiN+
0.210	1.000	0.250	2.50	HB2101000	HB2101000A	216366	216642
0.210	1.250	0.250	2.50	HB2101250	HB2101250A	216369	216645
0.210	1.500	0.250	2.50	HB2101500	HB2101500A	216372	216648
0.240	1.000	0.250	2.50	HB2401000	HB2401000A	216375	216651
0.240	1.500	0.250	2.50	HB2401500	HB2401500A	216378	216654
0.240	1.750	0.250	3.00	HB2401750	HB2401750A	216381	216657
0.300	1.000	0.312	2.50	HB3001000	HB3001000A	216384	216660
0.300	1.500	0.312	2.50	HB3001500	HB3001500A	216387	216663
0.300	1.750	0.312	3.00	HB3001750	HB3001750A	216390	216666
0.360	1.000	0.375	2.50	HB3601000	HB3601000A	216393	216669
0.360	1.500	0.375	2.50	HB3601500	HB3601500A	216396	216672
0.360	1.750	0.375	3.00	HB3601750	HB3601750A	216399	216675
0.360	2.000	0.375	4.00	HB3602000	HB3602000A	216402	216678
0.360	2.250	0.375	4.00	HB3602250	HB3602250A	216405	216681
0.360	2.500	0.375	4.00	HB3602500	HB3602500A	216408	216684
0.480	1.500	0.500	3.00	HB4801500	HB4801500A	216411	216687
0.480	2.000	0.500	3.00	HB4802000	HB4802000A	216414	216690
0.480	2.500	0.500	4.00	HB4802500	HB4802500A	216417	216693
0.480	3.000	0.500	4.00	HB4803000	HB4803000A	216420	216696
0.480	3.500	0.500	6.00	HB4803500	HB4803500A	216423	216699
0.480	4.000	0.500	6.00	HB4804000	HB4804000A	216426	216702
0.480	4.500	0.500	6.00	HB4804500	HB4804500A	216429	216705

[Go to Single Point Tools Overview](#)

BACK CHAMFER BORING BARS - SOLID CARBIDE

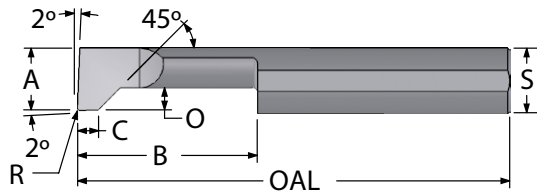

- Bar features multifunction design: bore, back bore, thread relief, and back chamfer
- ALTiN+ coating extends tool life
- Elliptically ground neck provides maximum strength
- Made with premium submicron grade carbide

"A" MIN BORE	"B" MAX DEPTH	"C" CUT WIDTH	"O" OFF SET	"R" TOOL RADIUS	"S" SHANK DIA.	OAL	ORDER #		EDP #	
							UNCOATED	ALTiN+	UNCOATED	ALTiN+
0.090	0.300	0.040	0.035	0.010	0.125	1.50	BC090300	BC090300A	216801	216864
0.090	0.400	0.040	0.035	0.010	0.125	1.50	BC090400	BC090400A	216804	216867
0.090	0.500	0.040	0.035	0.010	0.125	1.50	BC090500	BC090500A	216807	216870
0.120	0.400	0.050	0.045	0.010	0.125	1.50	BC120400	BC120400A	216810	216873
0.120	0.500	0.050	0.045	0.010	0.125	1.50	BC120500	BC120500A	216813	216876
0.120	0.600	0.050	0.045	0.010	0.125	1.50	BC120600	BC120600A	216816	216879
0.180	0.500	0.060	0.050	0.010	0.1875	2.00	BC180500	BC180500A	216819	216882
0.180	0.650	0.060	0.050	0.010	0.1875	2.00	BC180650	BC180650A	216822	216885
0.180	0.800	0.060	0.050	0.010	0.1875	2.00	BC180800	BC180800A	216825	216888
0.230	0.500	0.080	0.060	0.010	0.250	2.50	BC230500	BC230500A	216828	216891
0.230	0.700	0.080	0.060	0.010	0.250	2.50	BC230700	BC230700A	216831	216894
0.230	0.900	0.080	0.060	0.010	0.250	2.50	BC230900	BC230900A	216834	216897
0.290	0.700	0.080	0.080	0.010	0.3125	2.50	BC290700	BC290700A	216840	216903
0.290	0.900	0.080	0.080	0.010	0.3125	2.50	BC290900	BC290900A	216843	216906
0.290	1.100	0.080	0.080	0.010	0.3125	2.50	BC2901100	BC2901100A	216837	216900
0.360	0.750	0.100	0.120	0.010	0.375	2.50	BC360750	BC360750A	216852	216915
0.360	1.000	0.100	0.120	0.010	0.375	2.50	BC3601000	BC3601000A	216846	216909
0.360	1.250	0.100	0.120	0.010	0.375	2.50	BC3601250	BC3601250A	216849	216912
0.490	1.000	0.110	0.130	0.010	0.500	3.00	BC4901000	BC4901000A	216855	216918
0.490	1.250	0.110	0.130	0.010	0.500	3.00	BC4901250	BC4901250A	216858	216921
0.490	1.500	0.110	0.130	0.010	0.500	3.00	BC4901500	BC4901500A	216861	216924

[Go to Single Point Tools Overview](#)

PROFILE BORING BARS - SOLID CARBIDE

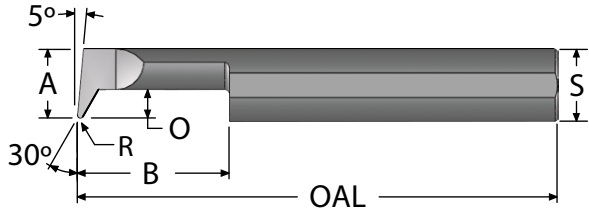

- Machines complex internal shapes with ease
- ALTiN+ coating allows higher Surface Feet per Minute
- Elliptically ground neck provides maximum strength
- Made with premium submicron grade carbide

"A" MIN BORE	"B" MAX DEPTH	"O" OFF SET	"R" TOOL RADIUS	"S" SHANK DIA.	OAL	ORDER #		EDP #	
						UNCOATED	ALTiN+	UNCOATED	ALTiN+
0.090	0.200	0.040	0.005	0.125	1.50	PB090200	PB090200A	217001	217070
0.090	0.300	0.040	0.005	0.125	1.50	PB090300	PB090300A	217004	217073
0.090	0.400	0.040	0.005	0.125	1.50	PB090400	PB090400A	217007	217076
0.120	0.250	0.050	0.007	0.125	1.50	PB120250	PB120250A	217010	217079
0.120	0.500	0.050	0.007	0.125	1.50	PB120500	PB120500A	217013	217082
0.120	0.750	0.050	0.007	0.125	1.50	PB120750	PB120750A	217016	217085
0.180	0.500	0.080	0.010	0.1875	2.00	PB180500	PB180500A	217022	217091
0.180	0.750	0.080	0.010	0.1875	2.00	PB180750	PB180750A	217025	217094
0.180	1.000	0.080	0.010	0.1875	2.00	PB1801000	PB1801000A	217019	217088
0.230	0.500	0.090	0.010	0.250	2.50	PB230500	PB230500A	217031	217100
0.230	0.750	0.090	0.010	0.250	2.50	PB230750	PB230750A	217034	217103
0.230	1.000	0.090	0.010	0.250	2.50	PB2301000	PB2301000A	217028	217097
0.290	0.500	0.110	0.015	0.3125	2.50	PB290500	PB290500A	217040	217109
0.290	0.750	0.110	0.015	0.3125	2.50	PB290750	PB290750A	217043	217112
0.290	1.000	0.110	0.015	0.3125	2.50	PB2901000	PB2901000A	217037	217106
0.360	0.500	0.140	0.015	0.375	2.50	PB360500	PB360500A	217052	217121
0.360	0.750	0.140	0.015	0.375	2.50	PB360750	PB360750A	217055	217124
0.360	1.000	0.140	0.015	0.375	2.50	PB3601000	PB3601000A	217046	217115
0.360	1.250	0.140	0.015	0.375	2.50	PB3601250	PB3601250A	217049	217118
0.490	0.500	0.180	0.015	0.500	3.00	PB490500	PB490500A	217064	217133
0.490	0.750	0.180	0.015	0.500	3.00	PB490750	PB490750A	217067	217136
0.490	1.000	0.180	0.015	0.500	3.00	PB4901000	PB4901000A	217058	217127
0.490	1.250	0.180	0.015	0.500	3.00	PB4901250	PB4901250A	217061	217130

[Go to Single Point Tools Overview](#)

FACE GROOVE TOOLS - SOLID CARBIDE

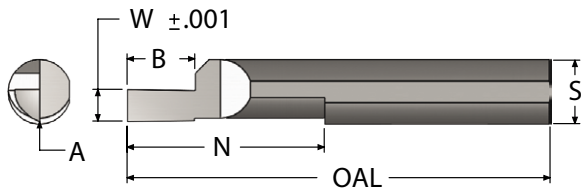

- ALTiN+ coating extends tool life
- Polished flute face for maximum performance
- Precision ground flat for guaranteed tool orientation
- Made with premium submicron grade carbide

"A" MIN. DIA.	"W" GROOVE WIDTH	"B" GROOVE DEPTH	"N" NECK RELIEF	"S" SHANK DIA.	OAL	ORDER #		EDP #	
						UNCOATED	ALTiN+	UNCOATED	ALTiN+
0.135	0.015	0.040	0.400	0.125	1.50	FG125-015	FG125-015A	220001	220013
0.135	0.020	0.050	0.400	0.125	1.50	FG125-020	FG125-020A	220004	220016
0.135	0.025	0.050	0.400	0.125	1.50	FG125-025	FG125-025A	220007	220019
0.135	0.030	0.060	0.400	0.125	1.50	FG125-030	FG125-030A	220010	220022
0.195	0.035	0.070	0.500	0.1875	2.00	FG187-035	FG187-035A	220025	220037
0.195	0.040	0.080	0.500	0.1875	2.00	FG187-040	FG187-040A	220028	220040
0.195	0.045	0.090	0.500	0.1875	2.00	FG187-045	FG187-045A	220031	220043
0.195	0.050	0.100	0.500	0.1875	2.00	FG187-050	FG187-050A	220034	220046
0.260	0.021	0.050	0.750	0.250	2.50	FG250-020	FG250-020A	220049	220061
0.260	0.031	0.060	0.750	0.250	2.50	FG250-030	FG250-030A	220052	220064
0.260	0.041	0.080	0.750	0.250	2.50	FG250-040	FG250-040A	220055	220067
0.260	0.051	0.100	0.750	0.250	2.50	FG250-050	FG250-050A	220058	220070
0.320	0.031	0.060	1.000	0.3125	2.50	FG312-030	FG312-030A	220073	220085
0.320	0.041	0.080	1.000	0.3125	2.50	FG312-040	FG312-040A	220076	220088
0.320	0.051	0.100	1.000	0.3125	2.50	FG312-050	FG312-050A	220079	220091
0.320	0.063	0.130	1.000	0.3125	2.50	FG312-062	FG312-062A	220082	220094
0.385	0.031	0.060	1.125	0.375	2.50	FG375-030	FG375-030A	220097	220109
0.385	0.063	0.130	1.125	0.375	2.50	FG375-062	FG375-062A	220100	220112
0.385	0.094	0.190	1.125	0.375	2.50	FG375-093	FG375-093A	220103	220115
0.385	0.126	0.250	1.125	0.375	2.50	FG375-125	FG375-125A	220106	220118
0.510	0.063	0.130	1.250	0.500	3.00	FG500-062	FG500-062A	220121	220133
0.510	0.094	0.190	1.250	0.500	3.00	FG500-093	FG500-093A	220124	220136
0.510	0.125	0.250	1.250	0.500	3.00	FG500-125	FG500-125A	220127	220139
0.510	0.157	0.310	1.250	0.500	3.00	FG500-156	FG500-156A	220130	220142
0.635	0.063	0.130	1.500	0.625	3.50	FG625-062	FG625-062A	220145	220160
0.635	0.094	0.190	1.500	0.625	3.50	FG625-093	FG625-093A	220148	220163
0.635	0.126	0.250	1.500	0.625	3.50	FG625-125	FG625-125A	220151	220166
0.635	0.157	0.310	1.500	0.625	3.50	FG625-156	FG625-156A	220154	220169
0.635	0.188	0.375	1.500	0.625	3.50	FG625-187	FG625-187A	220157	220172
0.760	0.063	0.130	1.750	0.750	4.00	FG750-062	FG750-062A	220175	220193
0.760	0.094	0.190	1.750	0.750	4.00	FG750-093	FG750-093A	220178	220196
0.760	0.126	0.250	1.750	0.750	4.00	FG750-125	FG750-125A	220181	220199
0.760	0.157	0.310	1.750	0.750	4.00	FG750-156	FG750-156A	220184	220202
0.760	0.188	0.375	1.750	0.750	4.00	FG750-187	FG750-187A	220187	220205
0.760	0.251	0.500	1.750	0.750	4.00	FG750-250	FG750-250A	220190	220208

[Go to Single Point Tools Overview](#)

GROOVE TOOLS - O-RING - SOLID CARBIDE

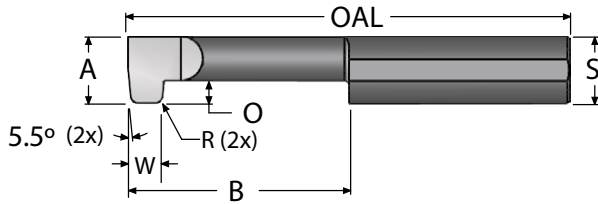

- ALTiN+ coating for higher Surface Feet per Minute
- Elliptically ground for maximum strength
- Made with premium submicron grade carbide

"A" MIN BORE	"W" GROOVE WIDTH	"B" MAX DEPTH	"R" CORNER RADIUS	"O" OFF SET	"S" SHANK DIA.	OAL	ORDER #		EDP #	
							UNCOATED	ALTiN+	UNCOATED	ALTiN+
0.250	0.097	0.500	0.015	0.110	0.250	2.50	GOR096-8	GOR096-8A	224801	224819
0.250	0.142	0.562	0.040	0.110	0.250	2.50	GOR141-9	GOR141-9A	224804	224822
0.250	0.145	0.625	0.040	0.110	0.250	2.50	GOR144-10	GOR144-10A	224807	224825
0.375	0.175	0.750	0.015	0.125	0.375	2.50	GOR174-12	GOR174-12A	224828	224846
0.375	0.209	0.812	0.040	0.125	0.375	2.50	GOR208-13	GOR208-13A	224831	224849
0.375	0.242	0.937	0.040	0.125	0.375	2.50	GOR241-15	GOR241-15A	224834	224852

UNDERCUT GROOVE TOOLS - SOLID CARBIDE

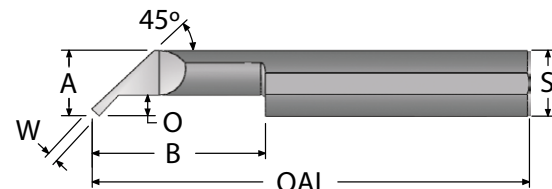
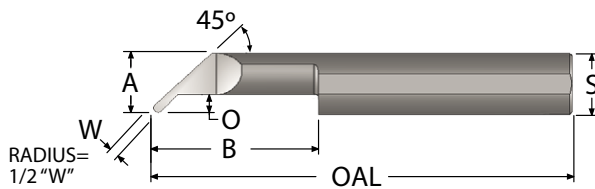

- Features a radius for undercut and profile
- Elliptically ground for maximum strength

- Tool does not have a cutting radius
- Polished flute face for best performance

UNDERCUT & PROFILE GROOVE TOOLS

"A" MIN BORE	"W" TOOL WIDTH	"B" MAX DEPTH	"O" OFF SET	"S" SHANK DIA.	OAL	ORDER #		EDP #	
						NOT COATED	ALTiN+	NOT COATED	ALTiN+
0.250	0.031	0.500	0.060	0.250	2.50	UP25030-8	UP25030-8A	220254	220260
0.250	0.031	1.000	0.060	0.250	2.50	UP25030-16	UP25030-16A	220251	220257
0.310	0.051	0.500	0.110	0.3125	2.50	UP31050-8	UP31050-8A	220266	220278
0.310	0.051	1.000	0.110	0.3125	2.50	UP31050-16	UP31050-16A	220263	220275
0.310	0.063	1.000	0.110	0.3125	2.50	UP31062-16	UP31062-16A	220269	220281
0.310	0.063	1.250	0.110	0.3125	2.50	UP31062-20	UP31062-20A	220272	220284
0.375	0.063	1.000	0.110	0.375	2.50	UP37062-16	UP37062-16A	220287	220305
0.375	0.063	1.250	0.110	0.375	2.50	UP37062-20	UP37062-20A	220290	220308
0.375	0.094	1.000	0.110	0.375	2.50	UP37093-16	UP37093-16A	220293	220311
0.375	0.094	1.250	0.110	0.375	2.50	UP37093-20	UP37093-20A	220296	220314
0.375	0.126	1.000	0.110	0.375	2.50	UP37125-16	UP37125-16A	220299	220317
0.375	0.126	1.250	0.110	0.375	2.50	UP37125-20	UP37125-20A	220302	220320
0.500	0.063	1.000	0.160	0.500	3.00	UP50062-16	UP50062-16A	220323	220341
0.500	0.063	1.500	0.160	0.500	3.00	UP50062-24	UP50062-24A	220326	220344
0.500	0.094	1.000	0.160	0.500	3.00	UP50093-16	UP50093-16A	220329	220347
0.500	0.094	1.500	0.160	0.500	3.00	UP50093-24	UP50093-24A	220332	220350
0.500	0.126	1.000	0.160	0.500	3.00	UP50125-16	UP50125-16A	220335	220353
0.500	0.126	1.500	0.160	0.500	3.00	UP50125-24	UP50125-24A	220338	220356

UNDERCUT GROOVE TOOLS

"A" MIN BORE	"W" TOOL WIDTH	"B" MAX DEPTH	"O" OFF SET	"S" SHANK DIA.	OAL	ORDER #		EDP #	
						NOT COATED	ALTiN+	NOT COATED	ALTiN+
0.250	0.031	0.500	0.060	0.250	2.50	UC25030-8	UC25030-8A	220404	220410
0.250	0.031	1.000	0.060	0.250	2.50	UC25030-16	UC25030-16A	220401	220407
0.310	0.051	0.500	0.110	0.3125	2.50	UC31050-8	UC31050-8A	220416	220428
0.310	0.051	1.000	0.110	0.3125	2.50	UC31050-16	UC31050-16A	220413	220425
0.310	0.063	1.000	0.110	0.3125	2.50	UC31062-16	UC31062-16A	220419	220431
0.310	0.063	1.250	0.110	0.3125	2.50	UC31062-20	UC31062-20A	220422	220434
0.375	0.063	1.000	0.110	0.375	2.50	UC37062-16	UC37062-16A	220437	220455
0.375	0.063	1.250	0.110	0.375	2.50	UC37062-20	UC37062-20A	220440	220458
0.375	0.094	1.000	0.110	0.375	2.50	UC37093-16	UC37093-16A	220443	220461
0.375	0.094	1.250	0.110	0.375	2.50	UC37093-20	UC37093-20A	220446	220464
0.375	0.126	1.000	0.110	0.375	2.50	UC37125-16	UC37125-16A	220449	220467
0.375	0.126	1.250	0.110	0.375	2.50	UC37125-20	UC37125-20A	220452	220470
0.500	0.063	1.000	0.160	0.500	3.00	UC50062-16	UC50062-16A	220473	220491
0.500	0.063	1.500	0.160	0.500	3.00	UC50062-24	UC50062-24A	220476	220494
0.500	0.094	1.000	0.160	0.500	3.00	UC50093-16	UC50093-16A	220479	220497
0.500	0.094	1.500	0.160	0.500	3.00	UC50093-24	UC50093-24A	220482	220500
0.500	0.126	1.000	0.160	0.500	3.00	UC50125-16	UC50125-16A	220485	220503
0.500	0.126	1.500	0.160	0.500	3.00	UC50125-24	UC50125-24A	220488	220506

GROOVE TOOLS - RETAINING RING - SOLID CARBIDE

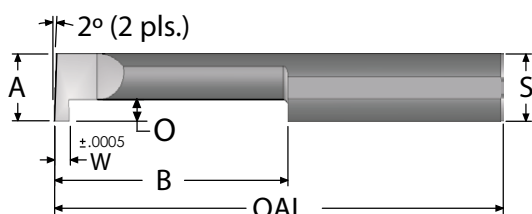

- ALTiN+ coating for higher Surface Feet per Minute
- Shank diameter is precision ground
- Made with premium submicron grade carbide

"A" MIN BORE	"W" TOOL WIDTH	"B" MAX DEPTH	"O" OFF SET	"S" SHANK DIA.	OAL	ORDER #		EDP #	
						UNCOATED	ALTiN+	UNCOATED	ALTiN+
0.060	0.0320	0.187	0.020	0.125	1.50	GT031-3	GT031-3A	220551	220611
0.060	0.0320	0.250	0.020	0.125	1.50	GT031-4	GT031-4A	220554	220614
0.060	0.0320	0.375	0.020	0.125	1.50	GT031-6	GT031-6A	220557	220617
0.090	0.0460	0.250	0.030	0.125	1.50	GT045-4	GT045-4A	220560	220620
0.090	0.0460	0.375	0.030	0.125	1.50	GT045-6	GT045-6A	220563	220623
0.090	0.0460	0.500	0.030	0.125	1.50	GT045-8	GT045-8A	220566	220626
0.120	0.0620	0.250	0.040	0.125	1.50	GT061-4	GT061-4A	220572	220632
0.120	0.0620	0.375	0.040	0.125	1.50	GT061-6	GT061-6A	220575	220635
0.120	0.0620	0.500	0.040	0.125	1.50	GT061-8	GT061-8A	220578	220638
0.120	0.0620	0.625	0.040	0.125	1.50	GT061-10	GT061-10A	220569	220629
0.187	0.0175	0.250	0.050	0.1875	2.00	GT017K-4	GT017K-4A	220644	220740
0.187	0.0175	0.375	0.050	0.1875	2.00	GT017K-6	GT017K-6A	220647	220743
0.187	0.0175	0.500	0.050	0.1875	2.00	GT017K-8	GT017K-8A	220650	220746
0.187	0.0175	0.625	0.050	0.1875	2.00	GT017K-10	GT017K-10A	220641	220737
0.187	0.0255	0.250	0.050	0.1875	2.00	GT025K-4	GT025K-4A	220656	220752
0.187	0.0255	0.375	0.050	0.1875	2.00	GT025K-6	GT025K-6A	220659	220755
0.187	0.0255	0.500	0.050	0.1875	2.00	GT025K-8	GT025K-8A	220662	220758
0.187	0.0255	0.625	0.050	0.1875	2.00	GT025K-10	GT025K-10A	220653	220749
0.187	0.0305	0.250	0.050	0.1875	2.00	GT030K-4	GT030K-4A	220668	220764
0.187	0.0305	0.375	0.050	0.1875	2.00	GT030K-6	GT030K-6A	220671	220767
0.187	0.0305	0.500	0.050	0.1875	2.00	GT030K-8	GT030K-8A	220674	220770
0.187	0.0305	0.625	0.050	0.1875	2.00	GT030K-10	GT030K-10A	220665	220761
0.187	0.0630	0.250	0.050	0.1875	2.00	GT062K-4	GT062K-4A	220680	220776
0.187	0.0630	0.375	0.050	0.1875	2.00	GT062K-6	GT062K-6A	220683	220779
0.187	0.0630	0.500	0.050	0.1875	2.00	GT062K-8	GT062K-8A	220686	220782
0.187	0.0630	0.625	0.050	0.1875	2.00	GT062K-10	GT062K-10A	220677	220773
0.250	0.0175	0.250	0.060	0.250	2.50	GT017Q-4	GT017Q-4A	220788	220908
0.250	0.0175	0.375	0.060	0.250	2.50	GT017Q-6	GT017Q-6A	220791	220911
0.250	0.0175	0.500	0.060	0.250	2.50	GT017Q-8	GT017Q-8A	220794	220914
0.250	0.0175	0.625	0.060	0.250	2.50	GT017Q-10	GT017Q-10A	220785	220905
0.250	0.0255	0.250	0.060	0.250	2.50	GT025Q-4	GT025Q-4A	220800	220920
0.250	0.0255	0.375	0.060	0.250	2.50	GT025Q-6	GT025Q-6A	220803	220923
0.250	0.0255	0.500	0.060	0.250	2.50	GT025Q-8	GT025Q-8A	220806	220926
0.250	0.0255	0.625	0.060	0.250	2.50	GT025Q-10	GT025Q-10A	220797	220917
0.250	0.0305	0.250	0.060	0.250	2.50	GT030Q-4	GT030Q-4A	220812	220932
0.250	0.0305	0.375	0.060	0.250	2.50	GT030Q-6	GT030Q-6A	220815	220935
0.250	0.0305	0.500	0.060	0.250	2.50	GT030Q-8	GT030Q-8A	220818	220938
0.250	0.0305	0.625	0.060	0.250	2.50	GT030Q-10	GT030Q-10A	220809	220929
0.250	0.0630	0.250	0.060	0.250	2.50	GT062Q-4	GT062Q-4A	220824	220944
0.250	0.0630	0.375	0.060	0.250	2.50	GT062Q-6	GT062Q-6A	220827	220947
0.250	0.0630	0.500	0.060	0.250	2.50	GT062Q-8	GT062Q-8A	220830	220950
0.250	0.0630	0.625	0.060	0.250	2.50	GT062Q-10	GT062Q-10A	220821	220941
0.250	0.0930	0.250	0.060	0.250	2.50	GT092Q-4	GT092Q-4A	220836	220956
0.250	0.0930	0.375	0.060	0.250	2.50	GT092Q-6	GT092Q-6A	220839	220959
0.250	0.0930	0.500	0.060	0.250	2.50	GT092Q-8	GT092Q-8A	220842	220962
0.250	0.0930	0.625	0.060	0.250	2.50	GT092Q-10	GT092Q-10A	220833	220953

Left-hand style available in all sizes. To order left-hand style, start order number with "LH."

THREAD MILLS
 SINGLE POINT TOOLS
 GROOVING
 INDEXABLE TOOLS
 PORT - CAVITY
 SPECIALTY

GROOVE TOOLS - RETAINING RING - SOLID CARBIDE

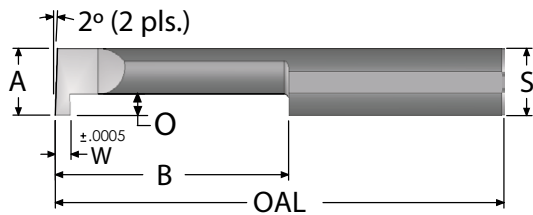

- ALTiN+ coating extends tool life
- Polished flute face for optimum performance
- Precision ground shank flat for guaranteed tool orientation

"A" MIN BORE	"W" TOOL WIDTH	"B" MAX DEPTH	"O" OFF SET	"S" SHANK DIA.	OAL	ORDER #		EDP #	
						UNCOATED	ALTiN+	UNCOATED	ALTiN+
0.312	0.0335	0.250	0.110	0.3125	2.50	GT033-4	GT033-4A	220968	221064
0.312	0.0335	0.375	0.110	0.3125	2.50	GT033-6	GT033-6A	220971	221067
0.312	0.0335	0.500	0.110	0.3125	2.50	GT033-8	GT033-8A	220974	221070
0.312	0.0335	0.750	0.110	0.3125	2.50	GT033-12	GT033-12A	220965	221061
0.312	0.0385	0.250	0.110	0.3125	2.50	GT038-4	GT038-4A	220980	221076
0.312	0.0385	0.375	0.110	0.3125	2.50	GT038-6	GT038-6A	220983	221079
0.312	0.0385	0.500	0.110	0.3125	2.50	GT038-8	GT038-8A	220986	221082
0.312	0.0385	0.750	0.110	0.3125	2.50	GT038-12	GT038-12A	220977	221073
0.312	0.0630	0.375	0.110	0.3125	2.50	GT063-6	GT063-6A	220995	221091
0.312	0.0630	0.500	0.110	0.3125	2.50	GT063-8	GT063-8A	220998	221094
0.312	0.0630	0.750	0.110	0.3125	2.50	GT063-12	GT063-12A	220989	221085
0.312	0.0630	1.000	0.110	0.3125	2.50	GT063-16	GT063-16A	220992	221088
0.312	0.1250	0.375	0.110	0.3125	2.50	GT124-6	GT124-6A	221007	221103
0.312	0.1250	0.500	0.110	0.3125	2.50	GT124-8	GT124-8A	221010	221106
0.312	0.1250	0.750	0.110	0.3125	2.50	GT124-12	GT124-12A	221001	221097
0.312	0.1250	0.500	0.110	0.3125	2.50	GT124-16	GT124-16A	221004	221100
0.375	0.040	0.250	0.110	0.375	2.50	GT039-4	GT039-4A	221118	221394
0.375	0.040	0.375	0.110	0.375	2.50	GT039-6	GT039-6A	221121	221397
0.375	0.040	0.500	0.110	0.375	2.50	GT039-8	GT039-8A	221124	221400
0.375	0.040	0.750	0.110	0.375	2.50	GT039-12	GT039-12A	221109	221385
0.375	0.040	1.000	0.110	0.375	2.50	GT039-16	GT039-16A	221112	221388
0.375	0.040	1.250	0.110	0.375	2.50	GT039-20	GT039-20A	221115	221391
0.375	0.047	0.250	0.110	0.375	2.50	GT046-4	GT046-4A	221136	221412
0.375	0.047	0.375	0.110	0.375	2.50	GT046-6	GT046-6A	221139	221415
0.375	0.047	0.500	0.110	0.375	2.50	GT046-8	GT046-8A	221142	221418
0.375	0.047	0.750	0.110	0.375	2.50	GT046-12	GT046-12A	221127	221403
0.375	0.047	1.000	0.110	0.375	2.50	GT046-16	GT046-16A	221130	221406
0.375	0.047	1.250	0.110	0.375	2.50	GT046-20	GT046-20A	221133	221409
0.375	0.056	0.250	0.110	0.375	2.50	GT055-4	GT055-4A	221154	221430
0.375	0.056	0.375	0.110	0.375	2.50	GT055-6	GT055-6A	221157	221433
0.375	0.056	0.500	0.110	0.375	2.50	GT055-8	GT055-8A	221160	221436
0.375	0.056	0.750	0.110	0.375	2.50	GT055-12	GT055-12A	221145	221421
0.375	0.056	1.000	0.110	0.375	2.50	GT055-16	GT055-16A	221148	221424
0.375	0.056	1.250	0.110	0.375	2.50	GT055-20	GT055-20A	221151	221427
0.375	0.063	0.250	0.110	0.375	2.50	GT062-4	GT062-4A	221172	221448
0.375	0.063	0.375	0.110	0.375	2.50	GT062-6	GT062-6A	221175	221451
0.375	0.063	0.500	0.110	0.375	2.50	GT062-8	GT062-8A	221178	221454
0.375	0.063	0.750	0.110	0.375	2.50	GT062-12	GT062-12A	221163	221439
0.375	0.063	1.000	0.110	0.375	2.50	GT062-16	GT062-16A	221166	221442
0.375	0.063	1.250	0.110	0.375	2.50	GT062-20	GT062-20A	221169	221445
0.375	0.070	0.250	0.110	0.375	2.50	GT069-4	GT069-4A	221190	221466
0.375	0.070	0.375	0.110	0.375	2.50	GT069-6	GT069-6A	221193	221469
0.375	0.070	0.500	0.110	0.375	2.50	GT069-8	GT069-8A	221196	221472
0.375	0.070	0.750	0.110	0.375	2.50	GT069-12	GT069-12A	221181	221457
0.375	0.070	1.000	0.110	0.375	2.50	GT069-16	GT069-16A	221184	221460
0.375	0.070	1.250	0.110	0.375	2.50	GT069-20	GT069-20A	221187	221463

Left-hand style available in all sizes. To order left-hand style, start order number with "LH."

[Go to Single Point Tools Overview](#)

GROOVE TOOLS - RETAINING RING - SOLID CARBIDE

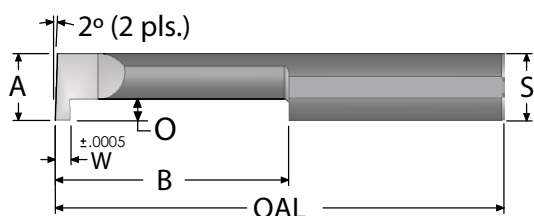

- ALTiN+ coating for higher Surface Feet per Minute
- Shank diameter is precision ground
- Polished flute face for optimum performance
- Made with premium submicron grade carbide

"A" MIN BORE	"W" TOOL WIDTH	"B" MAX DEPTH	"O" OFF SET	"S" SHANK DIA.	OAL	ORDER #		EDP #	
						UNCOATED	AITiN	UNCOATED	ALTiN+
0.375	0.088	0.250	0.110	0.375	2.50	GT087-4	GT087-4A	221208	221484
0.375	0.088	0.375	0.110	0.375	2.50	GT087-6	GT087-6A	221211	221487
0.375	0.088	0.500	0.110	0.375	2.50	GT087-8	GT087-8A	221214	221490
0.375	0.088	0.750	0.110	0.375	2.50	GT087-12	GT087-12A	221199	221475
0.375	0.088	1.000	0.110	0.375	2.50	GT087-16	GT087-16A	221202	221478
0.375	0.088	1.250	0.110	0.375	2.50	GT087-20	GT087-20A	221205	221481
0.375	0.127	0.375	0.110	0.375	2.50	GT126-6	GT126-6A	221226	221502
0.375	0.127	0.500	0.110	0.375	2.50	GT126-8	GT126-8A	221229	221505
0.375	0.127	0.750	0.110	0.375	2.50	GT126-12	GT126-12A	221217	221493
0.375	0.127	1.000	0.110	0.375	2.50	GT126-16	GT126-16A	221220	221496
0.375	0.127	1.250	0.110	0.375	2.50	GT126-20	GT126-20A	221223	221499
0.375	0.158	0.375	0.110	0.375	2.50	GT157-6	GT157-6A	221241	221517
0.375	0.158	0.500	0.110	0.375	2.50	GT157-8	GT157-8A	221244	221520
0.375	0.158	0.750	0.110	0.375	2.50	GT157-12	GT157-12A	221232	221508
0.375	0.158	1.000	0.110	0.375	2.50	GT157-16	GT157-16A	221235	221511
0.375	0.158	1.250	0.110	0.375	2.50	GT157-20	GT157-20A	221238	221514
0.500	0.094	0.500	0.160	0.500	3.00	GT093-8	GT093-8A	221535	221685
0.500	0.094	0.750	0.160	0.500	3.00	GT093-12	GT093-12A	221523	221673
0.500	0.094	1.000	0.160	0.500	3.00	GT093-16	GT093-16A	221526	221676
0.500	0.094	1.250	0.160	0.500	3.00	GT093-20	GT093-20A	221529	221679
0.500	0.094	1.500	0.160	0.500	3.00	GT093-24	GT093-24A	221532	221682
0.500	0.126	0.500	0.160	0.500	3.00	GT125-8	GT125-8A	221550	221700
0.500	0.126	0.750	0.160	0.500	3.00	GT125-12	GT125-12A	221538	221688
0.500	0.126	1.000	0.160	0.500	3.00	GT125-16	GT125-16A	221541	221691
0.500	0.126	1.250	0.160	0.500	3.00	GT125-20	GT125-20A	221544	221694
0.500	0.126	1.500	0.160	0.500	3.00	GT125-24	GT125-24A	221547	221697
0.500	0.157	0.500	0.160	0.500	3.00	GT156-8	GT156-8A	221565	221715
0.500	0.157	0.750	0.160	0.500	3.00	GT156-12	GT156-12A	221553	221703
0.500	0.157	1.000	0.160	0.500	3.00	GT156-16	GT156-16A	221556	221706
0.500	0.157	1.250	0.160	0.500	3.00	GT156-20	GT156-20A	221559	221709
0.500	0.157	1.500	0.160	0.500	3.00	GT156-24	GT156-24A	221562	221712
0.500	0.188	0.500	0.160	0.500	3.00	GT187-8	GT187-8A	221580	221730
0.500	0.188	0.750	0.160	0.500	3.00	GT187-12	GT187-12A	221568	221718
0.500	0.188	1.000	0.160	0.500	3.00	GT187-16	GT187-16A	221571	221721
0.500	0.188	1.250	0.160	0.500	3.00	GT187-20	GT187-20A	221574	221724
0.500	0.188	1.500	0.160	0.500	3.00	GT187-24	GT187-24A	221577	221727
0.500	0.251	0.500	0.160	0.500	3.00	GT250-8	GT250-8A	221595	221745
0.500	0.251	0.750	0.160	0.500	3.00	GT250-12	GT250-12A	221583	221733
0.500	0.251	1.000	0.160	0.500	3.00	GT250-16	GT250-16A	221586	221736
0.500	0.251	1.250	0.160	0.500	3.00	GT250-20	GT250-20A	221589	221739
0.500	0.251	1.500	0.160	0.500	3.00	GT250-24	GT250-24A	221592	221742

Left-hand style available in all sizes. To order left-hand style, start order number with "LH."

[Go to Single Point Tools Overview](#)

GROOVE TOOLS - FULL RADIUS - SOLID CARBIDE

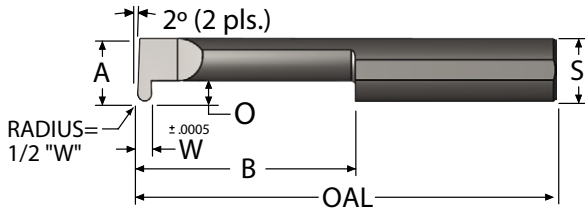

- ALTiN+ coating for higher Surface Feet per Minute
- Elliptically ground for maximum strength
- Polished flute face for optimum performance

THREAD MILLS

SINGLE POINT TOOLS
GROOVING

INDEXABLE TOOLS

PORT - CAVITY

SPECIALTY

"A" MIN BORE	"W" TOOL WIDTH	"B" MAX DEPTH	"O" OFF SET	"S" SHANK DIA.	OAL	ORDER #		EDP #	
						UNCOATED	ALTiN+	UNCOATED	ALTiN+
0.187	0.0175	0.250	0.050	0.1875	2.00	GFR017K-4	GFR017K-4A	221804	221876
0.187	0.0175	0.375	0.050	0.1875	2.00	GFR017K-6	GFR017K-6A	221807	221879
0.187	0.0175	0.500	0.050	0.1875	2.00	GFR017K-8	GFR017K-8A	221810	221882
0.187	0.0175	0.625	0.050	0.1875	2.00	GFR017K-10	GFR017K-10A	221801	221873
0.187	0.0255	0.250	0.050	0.1875	2.00	GFR025K-4	GFR025K-4A	221816	221888
0.187	0.0255	0.375	0.050	0.1875	2.00	GFR025K-6	GFR025K-6A	221819	221891
0.187	0.0255	0.500	0.050	0.1875	2.00	GFR025K-8	GFR025K-8A	221822	221894
0.187	0.0255	0.625	0.050	0.1875	2.00	GFR025K-10	GFR025K-10A	221813	221885
0.187	0.0305	0.250	0.050	0.1875	2.00	GFR030K-4	GFR030K-4A	221828	221900
0.187	0.0305	0.375	0.050	0.1875	2.00	GFR030K-6	GFR030K-6A	221831	221903
0.187	0.0305	0.500	0.050	0.1875	2.00	GFR030K-8	GFR030K-8A	221834	221906
0.187	0.0305	0.625	0.050	0.1875	2.00	GFR030K-10	GFR030K-10A	221825	221897
0.250	0.0175	0.250	0.060	0.250	2.50	GFR017Q-4	GFR017Q-4A	221912	221984
0.250	0.0175	0.375	0.060	0.250	2.50	GFR017Q-6	GFR017Q-6A	221915	221987
0.250	0.0175	0.500	0.060	0.250	2.50	GFR017Q-8	GFR017Q-8A	221918	221990
0.250	0.0175	0.625	0.060	0.250	2.50	GFR017Q-10	GFR017Q-10A	221909	221981
0.250	0.0255	0.250	0.060	0.250	2.50	GFR025Q-4	GFR025Q-4A	221924	221996
0.250	0.0255	0.375	0.060	0.250	2.50	GFR025Q-6	GFR025Q-6A	221927	221999
0.250	0.0255	0.500	0.060	0.250	2.50	GFR025Q-8	GFR025Q-8A	221930	222002
0.250	0.0255	0.625	0.060	0.250	2.50	GFR025Q-10	GFR025Q-10A	221921	221993
0.250	0.0305	0.250	0.060	0.250	2.50	GFR030Q-4	GFR030Q-4A	221936	222008
0.250	0.0305	0.375	0.060	0.250	2.50	GFR030Q-6	GFR030Q-6A	221939	222011
0.250	0.0305	0.500	0.060	0.250	2.50	GFR030Q-8	GFR030Q-8A	221942	222014
0.250	0.0305	0.625	0.060	0.250	2.50	GFR030Q-10	GFR030Q-10A	221933	222005
0.312	0.0335	0.250	0.110	0.3125	2.50	GFR033-4	GFR033-4A	222020	222068
0.312	0.0335	0.375	0.110	0.3125	2.50	GFR033-6	GFR033-6A	222023	222071
0.312	0.0335	0.500	0.110	0.3125	2.50	GFR033-8	GFR033-8A	222026	222074
0.312	0.0335	0.750	0.110	0.3125	2.50	GFR033-12	GFR033-12A	222017	222065
0.312	0.0385	0.250	0.110	0.3125	2.50	GFR038-4	GFR038-4A	222032	222080
0.312	0.0385	0.375	0.110	0.3125	2.50	GFR038-6	GFR038-6A	222035	222083
0.312	0.0385	0.500	0.110	0.3125	2.50	GFR038-8	GFR038-8A	222038	222086
0.312	0.0385	0.750	0.110	0.3125	2.50	GFR038-12	GFR038-12A	222029	222077
0.375	0.040	0.250	0.110	0.375	2.50	GFR039-4	GFR039-4A	222098	222344
0.375	0.040	0.375	0.110	0.375	2.50	GFR039-6	GFR039-6A	222101	222347
0.375	0.040	0.500	0.110	0.375	2.50	GFR039-8	GFR039-8A	222104	222350
0.375	0.040	0.750	0.110	0.375	2.50	GFR039-12	GFR039-12A	222089	222335
0.375	0.040	1.000	0.110	0.375	2.50	GFR039-16	GFR039-16A	222092	222338
0.375	0.040	1.250	0.110	0.375	2.50	GFR039-20	GFR039-20A	222095	222341
0.375	0.047	0.250	0.110	0.375	2.50	GFR046-4	GFR046-4A	222116	222362
0.375	0.047	0.375	0.110	0.375	2.50	GFR046-6	GFR046-6A	222119	222365
0.375	0.047	0.500	0.110	0.375	2.50	GFR046-8	GFR046-8A	222122	222368
0.375	0.047	0.750	0.110	0.375	2.50	GFR046-12	GFR046-12A	222107	222353
0.375	0.047	1.000	0.110	0.375	2.50	GFR046-16	GFR046-16A	222110	222356
0.375	0.047	1.250	0.110	0.375	2.50	GFR046-20	GFR046-20A	222113	222359
0.375	0.056	0.250	0.110	0.375	2.50	GFR055-4	GFR055-4A	222134	222380
0.375	0.056	0.375	0.110	0.375	2.50	GFR055-6	GFR055-6A	222137	222383
0.375	0.056	0.500	0.110	0.375	2.50	GFR055-8	GFR055-8A	222140	222386
0.375	0.056	0.750	0.110	0.375	2.50	GFR055-12	GFR055-12A	222125	222371
0.375	0.056	1.000	0.110	0.375	2.50	GFR055-16	GFR055-16A	222128	222374
0.375	0.056	1.250	0.110	0.375	2.50	GFR055-20	GFR055-20A	222131	222377

GROOVE TOOLS - FULL RADIUS - SOLID CARBIDE

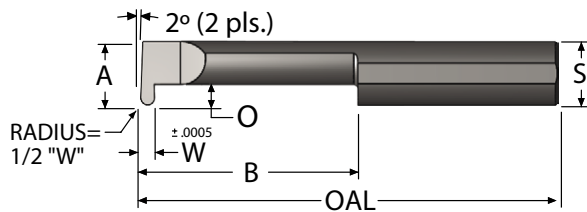

- ALTiN+ coating extends tool life
- Made with premium submicron grade carbide
- Precision ground shank flat for guaranteed tool orientation

"A" MIN BORE	"W" TOOL WIDTH	"B" MAX DEPTH	"O" OFF SET	"S" SHANK DIA.	OAL	ORDER #		EDP #	
						UNCOATED	ALTiN+	UNCOATED	ALTiN+
0.375	0.063	0.250	0.110	0.375	2.50	GFR062-4	GFR062-4A	222152	222398
0.375	0.063	0.375	0.110	0.375	2.50	GFR062-6	GFR062-6A	222155	222401
0.375	0.063	0.500	0.110	0.375	2.50	GFR062-8	GFR062-8A	222158	222404
0.375	0.063	0.750	0.110	0.375	2.50	GFR062-12	GFR062-12A	222143	222389
0.375	0.063	1.000	0.110	0.375	2.50	GFR062-16	GFR062-16A	222146	222392
0.375	0.063	1.250	0.110	0.375	2.50	GFR062-20	GFR062-20A	222149	222395
0.375	0.070	0.250	0.110	0.375	2.50	GFR069-4	GFR069-4A	222170	222416
0.375	0.070	0.375	0.110	0.375	2.50	GFR069-6	GFR069-6A	222173	222419
0.375	0.070	0.500	0.110	0.375	2.50	GFR069-8	GFR069-8A	222176	222422
0.375	0.070	0.750	0.110	0.375	2.50	GFR069-12	GFR069-12A	222161	222407
0.375	0.070	1.000	0.110	0.375	2.50	GFR069-16	GFR069-16A	222164	222410
0.375	0.070	1.250	0.110	0.375	2.50	GFR069-20	GFR069-20A	222167	222413
0.375	0.088	0.250	0.110	0.375	2.50	GFR087-4	GFR087-4A	222188	222434
0.375	0.088	0.375	0.110	0.375	2.50	GFR087-6	GFR087-6A	222191	222437
0.375	0.088	0.500	0.110	0.375	2.50	GFR087-8	GFR087-8A	222194	222440
0.375	0.088	0.750	0.110	0.375	2.50	GFR087-12	GFR087-12A	222179	222425
0.375	0.088	1.000	0.110	0.375	2.50	GFR087-16	GFR087-16A	222182	222428
0.375	0.088	1.250	0.110	0.375	2.50	GFR087-20	GFR087-20A	222185	222431
0.375	0.125	0.500	0.110	0.375	2.50	GFR124-8	GFR124-8A	222209	222455
0.375	0.125	0.750	0.110	0.375	2.50	GFR124-12	GFR124-12A	222197	222443
0.375	0.125	1.000	0.110	0.375	2.50	GFR124-16	GFR124-16A	222200	222446
0.375	0.125	1.250	0.110	0.375	2.50	GFR124-20	GFR124-20A	222203	222449
0.500	0.094	0.500	0.160	0.500	3.00	GFR093-8	GFR093-8A	222470	222620
0.500	0.094	0.750	0.160	0.500	3.00	GFR093-12	GFR093-12A	222458	222608
0.500	0.094	1.000	0.160	0.500	3.00	GFR093-16	GFR093-16A	222461	222611
0.500	0.094	1.250	0.160	0.500	3.00	GFR093-20	GFR093-20A	222464	222614
0.500	0.094	1.500	0.160	0.500	3.00	GFR093-24	GFR093-24A	222467	222617
0.500	0.126	0.500	0.160	0.500	3.00	GFR125-8	GFR125-8A	222485	222635
0.500	0.126	0.750	0.160	0.500	3.00	GFR125-12	GFR125-12A	222473	222623
0.500	0.126	1.000	0.160	0.500	3.00	GFR125-16	GFR125-16A	222476	222626
0.500	0.126	1.250	0.160	0.500	3.00	GFR125-20	GFR125-20A	222479	222629
0.500	0.126	1.500	0.160	0.500	3.00	GFR125-24	GFR125-24A	222482	222632
0.500	0.157	0.500	0.160	0.500	3.00	GFR156-8	GFR156-8A	222500	222650
0.500	0.157	0.750	0.160	0.500	3.00	GFR156-12	GFR156-12A	222488	222638
0.500	0.157	1.000	0.160	0.500	3.00	GFR156-16	GFR156-16A	222491	222641
0.500	0.157	1.250	0.160	0.500	3.00	GFR156-20	GFR156-20A	222494	222644
0.500	0.157	1.500	0.160	0.500	3.00	GFR156-24	GFR156-24A	222497	222647
0.500	0.188	0.500	0.160	0.500	3.00	GFR187-8	GFR187-8A	222515	222665
0.500	0.188	0.750	0.160	0.500	3.00	GFR187-12	GFR187-12A	222503	222653
0.500	0.188	1.000	0.160	0.500	3.00	GFR187-16	GFR187-16A	222506	222656
0.500	0.188	1.250	0.160	0.500	3.00	GFR187-20	GFR187-20A	222509	222659
0.500	0.188	1.500	0.160	0.500	3.00	GFR187-24	GFR187-24A	222512	222662
0.500	0.251	0.500	0.160	0.500	3.00	GFR250-8	GFR250-8A	222530	222680
0.500	0.251	0.750	0.160	0.500	3.00	GFR250-12	GFR250-12A	222518	222668
0.500	0.251	1.000	0.160	0.500	3.00	GFR250-16	GFR250-16A	222521	222671
0.500	0.251	1.250	0.160	0.500	3.00	GFR250-20	GFR250-20A	222524	222674
0.500	0.251	1.500	0.160	0.500	3.00	GFR250-24	GFR250-24A	222527	222677

Left-hand style available in all sizes. To order left-hand style, start order number with "LH."

THREADING TOOLS - SOLID CARBIDE

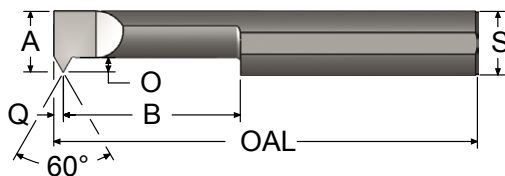

- 60° thread form for cutting UN, ISO, and NPT threads
- ALTiN+ coating extends tool life
- Precision ground shank flat guarantees tool orientation

THREAD MILLS

SINGLE POINT TOOLS
THREADING

INDEXABLE TOOLS

PORT - CAVITY

SPECIALTY

"A" MIN BORE	"B" MAX DEPTH	"O" MIN OFFSET	RECOM- MENDED TPI*	"Q" LENGTH	"S" SHANK DIA.	OAL	ORDER #		EDP #	
							UNCOATED	ALTiN+	UNCOATED	ALTiN+
0.040	0.080	0.013	56 to 80	0.009	0.125	1.50	TT040080	TT040080A	230001	230103
0.040	0.100	0.013	56 to 80	0.009	0.125	1.50	TT040100	TT040100A	230004	230106
0.040	0.130	0.013	56 to 80	0.009	0.125	1.50	TT040130	TT040130A	230007	230109
0.050	0.100	0.017	48 to 80	0.012	0.125	1.50	TT050100	TT050100A	230010	230112
0.050	0.150	0.017	48 to 80	0.012	0.125	1.50	TT050150	TT050150A	230013	230115
0.050	0.200	0.017	48 to 80	0.012	0.125	1.50	TT050200	TT050200A	230016	230118
0.060	0.150	0.020	40 to 80	0.014	0.125	1.50	TT060150	TT060150A	230019	230121
0.060	0.200	0.020	40 to 80	0.014	0.125	1.50	TT060200	TT060200A	230022	230124
0.060	0.250	0.020	40 to 80	0.014	0.125	1.50	TT060250	TT060250A	230025	230127
0.060	0.300	0.020	40 to 80	0.014	0.125	1.50	TT060300	TT060300A	230028	230130
0.075	0.200	0.020	36 to 72	0.014	0.125	1.50	TT075200	TT075200A	230031	230133
0.075	0.300	0.020	36 to 72	0.014	0.125	1.50	TT075300	TT075300A	230034	230136
0.075	0.400	0.020	36 to 72	0.014	0.125	1.50	TT075400	TT075400A	230037	230139
0.090	0.200	0.025	32 to 64	0.017	0.125	1.50	TT090200	TT090200A	230040	230142
0.090	0.300	0.025	32 to 64	0.017	0.125	1.50	TT090300	TT090300A	230043	230145
0.090	0.400	0.025	32 to 64	0.017	0.125	1.50	TT090400	TT090400A	230046	230148
0.090	0.500	0.025	32 to 64	0.017	0.125	1.50	TT090500	TT090500A	230049	230151
0.120	0.250	0.030	24 to 56	0.022	0.1875	2.00	TT120250	TT120250A	230154	230196
0.120	0.400	0.030	24 to 56	0.022	0.1875	2.00	TT120400	TT120400A	230157	230199
0.120	0.600	0.030	24 to 56	0.022	0.1875	2.00	TT120600	TT120600A	230160	230202
0.120	0.750	0.030	24 to 56	0.022	0.1875	2.00	TT120750	TT120750A	230163	230205
0.150	0.350	0.035	20 to 56	0.023	0.1875	2.00	TT150350	TT150350A	230166	230208
0.150	0.500	0.035	20 to 56	0.023	0.1875	2.00	TT150500	TT150500A	230169	230211
0.150	0.750	0.035	20 to 56	0.023	0.1875	2.00	TT150750	TT150750A	230172	230214
0.180	0.350	0.040	18 to 56	0.027	0.250	2.50	TT180350	TT180350A	230220	230271
0.180	0.500	0.040	18 to 56	0.027	0.250	2.50	TT180500	TT180500A	230223	230274
0.180	0.750	0.040	18 to 56	0.027	0.250	2.50	TT180750	TT180750A	230226	230277
0.180	1.000	0.040	18 to 56	0.027	0.250	2.50	TT1801000	TT1801000A	230217	230268
0.200	0.400	0.045	16 to 40	0.029	0.250	2.50	TT200400	TT200400A	230232	230283
0.200	0.600	0.045	16 to 40	0.029	0.250	2.50	TT200600	TT200600A	230235	230286
0.200	0.800	0.045	16 to 40	0.029	0.250	2.50	TT200800	TT200800A	230241	230292
0.200	1.000	0.045	16 to 40	0.029	0.250	2.50	TT2001000	TT2001000A	230229	230280
0.230	0.400	0.055	14 to 40	0.038	0.3125	2.50	TT230400	TT230400A	230304	230370
0.230	0.600	0.055	14 to 40	0.038	0.3125	2.50	TT230600	TT230600A	230307	230373
0.230	0.750	0.055	14 to 40	0.038	0.3125	2.50	TT230750	TT230750A	230310	230376
0.230	1.000	0.055	14 to 40	0.038	0.3125	2.50	TT2301000	TT2301000A	230295	230361
0.230	1.250	0.055	14 to 40	0.038	0.3125	2.50	TT2301250	TT2301250A	230298	230364
0.290	0.500	0.070	12 to 40	0.047	0.3125	2.50	TT290500	TT290500A	230325	230391
0.290	0.750	0.070	12 to 40	0.047	0.3125	2.50	TT290750	TT290750A	230328	230394
0.290	1.000	0.070	12 to 40	0.047	0.3125	2.50	TT2901000	TT2901000A	230313	230379
0.290	1.250	0.070	12 to 40	0.047	0.3125	2.50	TT2901250	TT2901250A	230316	230382
0.290	1.500	0.070	12 to 40	0.047	0.3125	2.50	TT2901500	TT2901500A	230319	230385
0.320	0.500	0.075	10 to 32	0.049	0.375	2.50	TT320500	TT320500A	230409	230469
0.320	0.750	0.075	10 to 32	0.049	0.375	2.50	TT320750	TT320750A	230412	230472
0.320	1.000	0.075	10 to 32	0.049	0.375	2.50	TT3201000	TT3201000A	230397	230457
0.320	1.250	0.075	10 to 32	0.049	0.375	2.50	TT3201250	TT3201250A	230400	230460
0.320	1.500	0.075	10 to 32	0.049	0.375	2.50	TT3201500	TT3201500A	230403	230463
0.360	0.500	0.080	8 to 32	0.057	0.375	2.50	TT360500	TT360500A	230424	230484
0.360	0.750	0.080	8 to 32	0.057	0.375	2.50	TT360750	TT360750A	230427	230487
0.360	1.000	0.080	8 to 32	0.057	0.375	2.50	TT3601000	TT3601000A	230415	230475
0.360	1.250	0.080	8 to 32	0.057	0.375	2.50	TT3601250	TT3601250A	230418	230478
0.360	1.500	0.080	8 to 32	0.057	0.375	2.50	TT3601500	TT3601500A	230421	230481
0.360	1.800	0.080	8 to 32	0.057	0.375	3.00	TT3601800	TT3601800A	230490	230496
0.490	0.750	0.120	8 to 32	0.077	0.500	3.00	TT490750	TT490750A	230505	230523
0.490	1.500	0.120	8 to 32	0.077	0.500	3.00	TT4901500	TT4901500A	230499	230517
0.490	2.000	0.120	8 to 32	0.077	0.500	3.00	TT4902000	TT4902000A	230502	230520

*TPI = Threads Per Inch

LEFT HAND THREADING TOOLS - SOLID CARBIDE

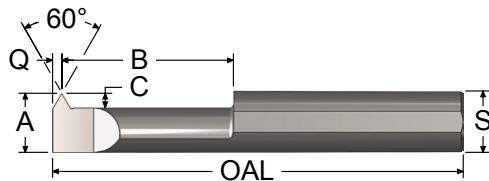

- 60° thread form for cutting UN, ISO, and NPT threads
- ALTiN+ coating extends tool life
- Precision ground shank flat guarantees tool orientation

"A" MIN BORE	"B" MAX DEPTH	"C" MIN OFFSET	RECOM- MENDED TPI*	"Q" LENGTH	"S" SHANK DIA.	OAL	ORDER #		EDP #	
							UNCOATED	ALTiN+	UNCOATED	ALTiN+
0.040	0.080	0.013	56 to 80	0.009	0.125	1.50	LHTT040080	LHTT040080A	231501	231603
0.040	0.100	0.013	56 to 80	0.009	0.125	1.50	LHTT040100	LHTT040100A	231504	231606
0.040	0.130	0.013	56 to 80	0.009	0.125	1.50	LHTT040130	LHTT040130A	231507	231609
0.050	0.100	0.017	48 to 80	0.012	0.125	1.50	LHTT050100	LHTT050100A	231510	231612
0.050	0.150	0.017	48 to 80	0.012	0.125	1.50	LHTT050150	LHTT050150A	231513	231615
0.050	0.200	0.017	48 to 80	0.012	0.125	1.50	LHTT050200	LHTT050200A	231516	231618
0.060	0.150	0.020	40 to 80	0.014	0.125	1.50	LHTT060150	LHTT060150A	231519	231621
0.060	0.200	0.020	40 to 80	0.014	0.125	1.50	LHTT060200	LHTT060200A	231522	231624
0.060	0.250	0.020	40 to 80	0.014	0.125	1.50	LHTT060250	LHTT060250A	231525	231627
0.060	0.300	0.020	40 to 80	0.014	0.125	1.50	LHTT060300	LHTT060300A	231528	231630
0.075	0.200	0.020	36 to 72	0.014	0.125	1.50	LHTT075200	LHTT075200A	231531	231633
0.075	0.300	0.020	36 to 72	0.014	0.125	1.50	LHTT075300	LHTT075300A	231534	231636
0.075	0.400	0.020	36 to 72	0.014	0.125	1.50	LHTT075400	LHTT075400A	231537	231639
0.090	0.200	0.025	32 to 64	0.017	0.125	1.50	LHTT090200	LHTT090200A	231540	231642
0.090	0.300	0.025	32 to 64	0.017	0.125	1.50	LHTT090300	LHTT090300A	231543	231645
0.090	0.400	0.025	32 to 64	0.017	0.125	1.50	LHTT090400	LHTT090400A	231546	231648
0.090	0.500	0.025	32 to 64	0.017	0.125	1.50	LHTT090500	LHTT090500A	231549	231651
0.120	0.250	0.030	24 to 56	0.021	0.1875	2.00	LHTT120250	LHTT120250A	231654	231696
0.120	0.400	0.030	24 to 56	0.021	0.1875	2.00	LHTT120400	LHTT120400A	231657	231699
0.120	0.600	0.030	24 to 56	0.021	0.1875	2.00	LHTT120600	LHTT120600A	231660	231702
0.120	0.750	0.030	24 to 56	0.021	0.1875	2.00	LHTT120750	LHTT120750A	231663	231705
0.150	0.350	0.035	20 to 56	0.023	0.1875	2.00	LHTT150350	LHTT150350A	231666	231708
0.150	0.500	0.035	20 to 56	0.023	0.1875	2.00	LHTT150500	LHTT150500A	231669	231711
0.150	0.750	0.035	20 to 56	0.023	0.1875	2.00	LHTT150750	LHTT150750A	231672	231714
0.180	0.350	0.040	18 to 56	0.027	0.250	2.50	LHTT180350	LHTT180350A	231720	231768
0.180	0.500	0.040	18 to 56	0.027	0.250	2.50	LHTT180500	LHTT180500A	231723	231771
0.180	0.750	0.040	18 to 56	0.027	0.250	2.50	LHTT180750	LHTT180750A	231726	231774
0.180	1.000	0.040	18 to 56	0.027	0.250	2.50	LHTT1801000	LHTT1801000A	231717	231765
0.200	0.400	0.045	16 to 40	0.029	0.250	2.50	LHTT200400	LHTT200400A	231732	231780
0.200	0.600	0.045	16 to 40	0.029	0.250	2.50	LHTT200600	LHTT200600A	231735	231783
0.200	0.800	0.045	16 to 40	0.029	0.250	2.50	LHTT200800	LHTT200800A	231738	231786
0.200	1.000	0.045	16 to 40	0.029	0.250	2.50	LHTT2001000	LHTT2001000A	231729	231777
0.230	0.400	0.055	14 to 40	0.038	0.3125	2.50	LHTT230400	LHTT230400A	231795	231855
0.230	0.600	0.055	14 to 40	0.038	0.3125	2.50	LHTT230600	LHTT230600A	231798	231858
0.230	0.750	0.055	14 to 40	0.038	0.3125	2.50	LHTT230750	LHTT230750A	231801	231861
0.230	1.000	0.055	14 to 40	0.038	0.3125	2.50	LHTT2301000	LHTT2301000A	231789	231849
0.230	1.250	0.055	14 to 40	0.038	0.3125	2.50	LHTT2301250	LHTT2301250A	231792	231852
0.290	0.500	0.070	12 to 40	0.047	0.3125	2.50	LHTT290500	LHTT290500A	231813	231873
0.290	0.750	0.070	12 to 40	0.047	0.3125	2.50	LHTT290750	LHTT290750A	231816	231876
0.290	1.000	0.070	12 to 40	0.047	0.3125	2.50	LHTT2901000	LHTT2901000A	231804	231864
0.290	1.250	0.070	12 to 40	0.047	0.3125	2.50	LHTT2901250	LHTT2901250A	231807	231867
0.290	1.500	0.070	12 to 40	0.047	0.3125	2.50	LHTT2901500	LHTT2901500A	231810	231870
0.320	0.500	0.075	10 to 32	0.049	0.375	2.50	LHTT320500	LHTT320500A	231888	231942
0.320	0.750	0.075	10 to 32	0.049	0.375	2.50	LHTT320750	LHTT320750A	231891	231945
0.320	1.000	0.075	10 to 32	0.049	0.375	2.50	LHTT3201000	LHTT3201000A	231879	231933
0.320	1.250	0.075	10 to 32	0.049	0.375	2.50	LHTT3201250	LHTT3201250A	231882	231936
0.320	1.500	0.075	10 to 32	0.049	0.375	2.50	LHTT3201500	LHTT3201500A	231885	231939
0.360	0.500	0.080	8 to 32	0.057	0.375	2.50	LHTT360500	LHTT360500A	231900	231954
0.360	0.750	0.080	8 to 32	0.057	0.375	2.50	LHTT360750	LHTT360750A	231903	231957
0.360	1.000	0.080	8 to 32	0.057	0.375	2.50	LHTT3601000	LHTT3601000A	231894	231948
0.360	1.250	0.080	8 to 32	0.057	0.375	2.50	LHTT3601250	LHTT3601250A	231897	231951
0.360	1.500	0.080	8 to 32	0.057	0.375	2.50	LHTT3601500	LHTT3601500A	231899	231953
0.360	1.800	0.080	8 to 32	0.057	0.375	2.50	LHTT3601800	LHTT3601800A	231960	231966
0.490	0.750	0.120	8 to 32	0.077	0.500	3.00	LHTT490750	LHTT490750A	231975	231993
0.490	1.500	0.120	8 to 32	0.077	0.500	3.00	LHTT4901500	LHTT4901500A	231969	231987
0.490	2.000	0.120	8 to 32	0.077	0.500	3.00	LHTT4902000	LHTT4902000A	231972	231990

*TPI = Threads Per Inch

THREADING TOOLS QUALIFIED - SOLID CARBIDE

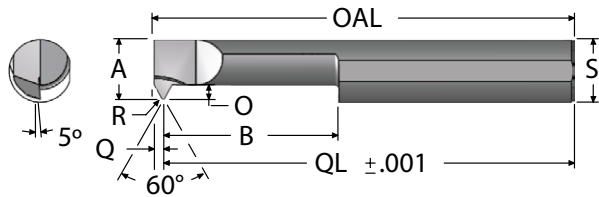

- 60° thread form for cutting UN, ISO, and NPT threads
- Positive rake improves surface finish and reduces burrs
- ALTiN+ coating provides better surface finish

"A" MIN BORE	"B" MAX DEPTH	"O" MIN OFFSET	"Q" LENGTH ±.001	"R" TOOL RADIUS	"QL" LENGTH ±.001	RECOM- MENDED TPI*	"S" SHANK DIA.	OAL	ORDER #		EDP #	
									UNCOATED	ALTiN+	UNCOATED	ALTiN+
0.060	0.150	0.020	0.014	0.0012	1.486	40 to 80	0.125	1.50	TTQ060150	TTQ060150A	230601	230634
0.060	0.200	0.020	0.014	0.0012	1.486	40 to 80	0.125	1.50	TTQ060200	TTQ060200A	230604	230637
0.060	0.250	0.020	0.014	0.0012	1.486	40 to 80	0.125	1.50	TTQ060250	TTQ060250A	230607	230640
0.060	0.300	0.020	0.014	0.0012	1.486	40 to 80	0.125	1.50	TTQ060300	TTQ060300A	230610	230643
0.075	0.200	0.020	0.014	0.0013	1.486	36 to 72	0.125	1.50	TTQ075200	TTQ075200A	230613	230646
0.075	0.300	0.020	0.014	0.0013	1.486	36 to 72	0.125	1.50	TTQ075300	TTQ075300A	230616	230649
0.075	0.400	0.020	0.014	0.0013	1.486	36 to 72	0.125	1.50	TTQ075400	TTQ075400A	230619	230652
0.090	0.200	0.025	0.017	0.0015	1.483	32 to 64	0.125	1.50	TTQ090200	TTQ090200A	230622	230655
0.090	0.300	0.025	0.017	0.0015	1.483	32 to 64	0.125	1.50	TTQ090300	TTQ090300A	230625	230658
0.090	0.400	0.025	0.017	0.0015	1.483	32 to 64	0.125	1.50	TTQ090400	TTQ090400A	230628	230661
0.090	0.500	0.025	0.017	0.0015	1.483	32 to 64	0.125	1.50	TTQ090500	TTQ090500A	230631	230664
0.120	0.250	0.030	0.021	0.0017	1.979	24 to 56	0.1875	2.00	TTQ120250	TTQ120250A	230667	230688
0.120	0.400	0.030	0.021	0.0017	1.979	24 to 56	0.1875	2.00	TTQ120400	TTQ120400A	230670	230691
0.120	0.600	0.030	0.021	0.0017	1.979	24 to 56	0.1875	2.00	TTQ120600	TTQ120600A	230673	230694
0.120	0.750	0.030	0.021	0.0017	1.979	24 to 56	0.1875	2.00	TTQ120750	TTQ120750A	230676	230697
0.150	0.350	0.035	0.023	0.0017	1.977	20 to 56	0.1875	2.00	TTQ150350	TTQ150350A	230679	230700
0.150	0.500	0.035	0.023	0.0017	1.977	20 to 56	0.1875	2.00	TTQ150500	TTQ150500A	230682	230703
0.150	0.750	0.035	0.023	0.0017	1.977	20 to 56	0.1875	2.00	TTQ150750	TTQ150750A	230685	230706
0.180	0.350	0.040	0.027	0.0017	2.473	18 to 56	0.250	2.50	TTQ180350	TTQ180350A	230712	230736
0.180	0.500	0.040	0.027	0.0017	2.473	18 to 56	0.250	2.50	TTQ180500	TTQ180500A	230715	230739
0.180	0.750	0.040	0.027	0.0017	2.473	18 to 56	0.250	2.50	TTQ180750	TTQ180750A	230718	230742
0.180	1.000	0.040	0.027	0.0017	2.473	18 to 56	0.250	2.50	TTQ1801000	TTQ1801000A	230709	230733
0.200	0.400	0.045	0.029	0.0024	2.471	16 to 40	0.250	2.50	TTQ200400	TTQ200400A	230724	230748
0.200	0.600	0.045	0.029	0.0024	2.471	16 to 40	0.250	2.50	TTQ200600	TTQ200600A	230727	230751
0.200	0.800	0.045	0.029	0.0024	2.471	16 to 40	0.250	2.50	TTQ200800	TTQ200800A	230730	230754
0.200	1.000	0.045	0.029	0.0024	2.471	16 to 40	0.250	2.50	TTQ2001000	TTQ2001000A	230721	230745
0.230	0.600	0.055	0.038	0.0024	2.462	14 to 40	0.3125	2.50	TTQ230600	TTQ230600A	230766	230796
0.230	0.750	0.055	0.038	0.0024	2.462	14 to 40	0.3125	2.50	TTQ230750	TTQ230750A	230769	230799
0.230	1.000	0.055	0.038	0.0024	2.462	14 to 40	0.3125	2.50	TTQ2301000	TTQ2301000A	230757	230787
0.230	1.250	0.055	0.038	0.0024	2.462	14 to 40	0.3125	2.50	TTQ2301250	TTQ2301250A	230760	230790
0.290	0.500	0.070	0.047	0.0024	2.453	12 to 40	0.3125	2.50	TTQ290500	TTQ290500A	230781	230811
0.290	0.750	0.070	0.047	0.0024	2.453	12 to 40	0.3125	2.50	TTQ290750	TTQ290750A	230784	230814
0.290	1.000	0.070	0.047	0.0024	2.453	12 to 40	0.3125	2.50	TTQ2901000	TTQ2901000A	230772	230802
0.290	1.250	0.070	0.047	0.0024	2.453	12 to 40	0.3125	2.50	TTQ2901250	TTQ2901250A	230775	230805
0.290	1.500	0.070	0.047	0.0024	2.453	12 to 40	0.3125	2.50	TTQ2901500	TTQ2901500A	230778	230808
0.320	0.500	0.075	0.049	0.0030	2.451	10 to 32	0.375	2.50	TTQ320500	TTQ320500A	230826	230856
0.320	0.750	0.075	0.049	0.0030	2.451	10 to 32	0.375	2.50	TTQ320750	TTQ320750A	230829	230859
0.320	1.000	0.075	0.049	0.0030	2.451	10 to 32	0.375	2.50	TTQ3201000	TTQ3201000A	230817	230847
0.320	1.250	0.075	0.049	0.0030	2.451	10 to 32	0.375	2.50	TTQ3201250	TTQ3201250A	230820	230850
0.320	1.500	0.075	0.049	0.0030	2.451	10 to 32	0.375	2.50	TTQ3201500	TTQ3201500A	230823	230853
0.360	0.500	0.080	0.057	0.0040	2.443	8 to 24	0.375	2.50	TTQ360500	TTQ360500A	230841	230871
0.360	0.750	0.080	0.057	0.0040	2.443	8 to 24	0.375	2.50	TTQ360750	TTQ360750A	230844	230874
0.360	1.000	0.080	0.057	0.0040	2.443	8 to 24	0.375	2.50	TTQ3601000	TTQ3601000A	230832	230862
0.360	1.250	0.080	0.057	0.0040	2.443	8 to 24	0.375	2.50	TTQ3601250	TTQ3601250A	230835	230865
0.360	1.500	0.080	0.057	0.0040	2.443	8 to 24	0.375	2.50	TTQ3601500	TTQ3601500A	230838	230868

*TPI = Threads Per Inch

Compatible holders with backstops: see pages 35 and 37.

[Go to Single Point Tools Overview](#)

ACME THREADING TOOLS - SOLID CARBIDE

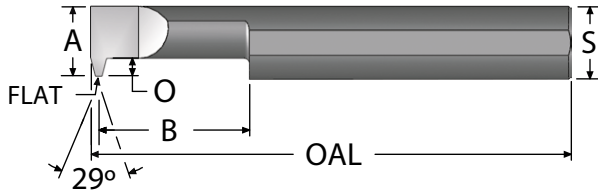

- ALTiN+ coating provides better surface finish
- Elliptically ground neck provides maximum strength
- Polished flute face for optimum performance

MIN THREAD SIZE*	"A" MIN HOLE	"B" MAX DEPTH	FLAT WIDTH	"O" OFF SET	"S" SHANK DIA.	OAL	ORDER #		EDP #	
							UNCOATED	ALTiN+	UNCOATED	ALTiN+
1/4-16	0.180	0.350	0.021	0.045	0.250	2.50	FAT180350-16	FAT180350-16A	230904	230928
1/4-16	0.180	0.500	0.021	0.045	0.250	2.50	FAT180500-16	FAT180500-16A	230907	230931
1/4-16	0.180	0.750	0.021	0.045	0.250	2.50	FAT180750-16	FAT180750-16A	230910	230934
1/4-16	0.180	1.000	0.021	0.045	0.250	2.50	FAT1801000-16	FAT1801000-16A	230901	230925
5/16-14	0.230	0.400	0.024	0.055	0.3125	2.50	FAT230400-14	FAT230400-14A	230943	231003
5/16-14	0.230	0.600	0.024	0.055	0.3125	2.50	FAT230600-14	FAT230600-14A	230946	231006
5/16-14	0.230	0.750	0.024	0.055	0.3125	2.50	FAT230750-14	FAT230750-14A	230949	231009
5/16-14	0.230	1.000	0.024	0.055	0.3125	2.50	FAT2301000-14	FAT2301000-14A	230937	230997
5/16-14	0.230	1.250	0.024	0.055	0.3125	2.50	FAT2301250-14	FAT2301250-14A	230940	231000
3/8-12	0.290	0.400	0.028	0.070	0.3125	2.50	FAT290400-12	FAT290400-12A	230958	231018
3/8-12	0.290	0.600	0.028	0.070	0.3125	2.50	FAT290600-12	FAT290600-12A	230961	231021
3/8-12	0.290	0.750	0.028	0.070	0.3125	2.50	FAT290750-12	FAT290750-12A	230964	231024
3/8-12	0.290	1.000	0.028	0.070	0.3125	2.50	FAT2901000-12	FAT2901000-12A	230952	231012
3/8-12	0.290	1.250	0.028	0.070	0.3125	2.50	FAT2901250-12	FAT2901250-12A	230955	231015
1/2-10	0.360	0.500	0.032	0.085	0.375	2.50	FAT360500-10	FAT360500-10A	231036	231066
1/2-10	0.360	0.750	0.032	0.085	0.375	2.50	FAT360750-10	FAT360750-10A	231039	231069
1/2-10	0.360	1.000	0.032	0.085	0.375	2.50	FAT3601000-10	FAT3601000-10A	231027	231057
1/2-10	0.360	1.250	0.032	0.085	0.375	2.50	FAT3601250-10	FAT3601250-10A	231030	231060
1/2-10	0.360	1.500	0.032	0.085	0.375	2.50	FAT3601500-10	FAT3601500-10A	231033	231063
5/8-8	0.490	0.750	0.041	0.120	0.500	3.00	FAT490750-8	FAT490750-8A	231096	231150
5/8-8	0.490	1.000	0.041	0.120	0.500	3.00	FAT4901000-8	FAT4901000-8A	231078	231132
5/8-8	0.490	2.000	0.041	0.120	0.500	3.00	FAT4902000-8	FAT4902000-8A	231087	231141
3/4-6	0.490	0.750	0.057	0.120	0.500	3.00	FAT490750-6	FAT490750-6A	231093	231147
3/4-6	0.490	1.000	0.057	0.120	0.500	3.00	FAT4901000-6	FAT4901000-6A	231075	231129
3/4-6	0.490	2.000	0.057	0.120	0.500	3.00	FAT4902000-6	FAT4902000-6A	231084	231138
1.0-5	0.490	0.750	0.069	0.130	0.500	3.00	FAT490750-5	FAT490750-5A	231090	231144
1.0-5	0.490	1.000	0.069	0.130	0.500	3.00	FAT4901000-5	FAT4901000-5A	231072	231126
1.0-5	0.490	2.000	0.069	0.130	0.500	3.00	FAT4902000-5	FAT4902000-5A	231081	231135

[Go to Single Point Tools Overview](#)

STUB ACME THREADING TOOLS - SOLID CARBIDE

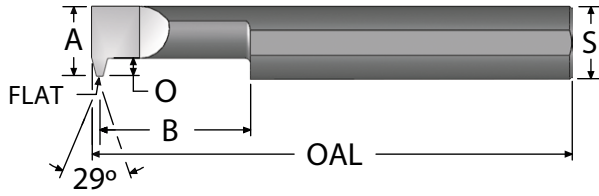

- ALTiN+ coating extends tool life
- Polished flute face for optimum performance
- Made with premium submicron grade carbide

MIN THREAD SIZE*	"A" MIN HOLE	"B" MAX DEPTH	FLAT WIDTH	"O" OFF SET	"S" SHANK DIA.	OAL	ORDER #		EDP #	
							UNCOATED	ALTiN+	UNCOATED	ALTiN+
1/4-16	0.180	0.350	0.024	0.045	0.250	2.50	SAT180350-16	SAT180350-16A	231204	231228
1/4-16	0.180	0.500	0.024	0.045	0.250	2.50	SAT180500-16	SAT180500-16A	231207	231231
1/4-16	0.180	0.750	0.024	0.045	0.250	2.50	SAT180750-16	SAT180750-16A	231210	231234
1/4-16	0.180	1.000	0.024	0.045	0.250	2.50	SAT1801000-16	SAT1801000-16A	231201	231225
5/16-14	0.230	0.400	0.028	0.055	0.3125	2.50	SAT230400-14	SAT230400-14A	231243	231303
5/16-14	0.230	0.600	0.028	0.055	0.3125	2.50	SAT230600-14	SAT230600-14A	231246	231306
5/16-14	0.230	0.750	0.028	0.055	0.3125	2.50	SAT230750-14	SAT230750-14A	231249	231309
5/16-14	0.230	1.000	0.028	0.055	0.3125	2.50	SAT2301000-14	SAT2301000-14A	231237	231297
5/16-14	0.230	1.250	0.028	0.055	0.3125	2.50	SAT2301250-14	SAT2301250-14A	231240	231300
3/8-12	0.290	0.400	0.033	0.070	0.3125	2.50	SAT290400-12	SAT290400-12A	231258	231318
3/8-12	0.290	0.600	0.033	0.070	0.3125	2.50	SAT290600-12	SAT290600-12A	231261	231321
3/8-12	0.290	0.750	0.033	0.070	0.3125	2.50	SAT290750-12	SAT290750-12A	231264	231324
3/8-12	0.290	1.000	0.033	0.070	0.3125	2.50	SAT2901000-12	SAT2901000-12A	231252	231312
3/8-12	0.290	1.250	0.033	0.070	0.3125	2.50	SAT2901250-12	SAT2901250-12A	231255	231315
1/2-10	0.360	0.500	0.037	0.085	0.375	2.50	SAT360500-10	SAT360500-10A	231336	231366
1/2-10	0.360	0.750	0.037	0.085	0.375	2.50	SAT360750-10	SAT360750-10A	231339	231369
1/2-10	0.360	1.000	0.037	0.085	0.375	2.50	SAT3601000-10	SAT3601000-10A	231327	231357
1/2-10	0.360	1.250	0.037	0.085	0.375	2.50	SAT3601250-10	SAT3601250-10A	231330	231360
1/2-10	0.360	1.500	0.037	0.085	0.375	2.50	SAT3601500-10	SAT3601500-10A	231333	231363
5/8-8	0.490	0.750	0.048	0.120	0.500	3.00	SAT490750-8	SAT490750-8A	231396	231450
5/8-8	0.490	1.000	0.048	0.120	0.500	3.00	SAT4901000-8	SAT4901000-8A	231378	231432
5/8-8	0.490	2.000	0.048	0.120	0.500	3.00	SAT4902000-8	SAT4902000-8A	231387	231441
3/4-6	0.490	0.750	0.065	0.120	0.500	3.00	SAT490750-6	SAT490750-6A	231393	231447
3/4-6	0.490	1.000	0.065	0.120	0.500	3.00	SAT4901000-6	SAT4901000-6A	231375	231429
3/4-6	0.490	2.000	0.065	0.120	0.500	3.00	SAT4902000-6	SAT4902000-6A	231384	231438
1.0-5	0.490	0.750	0.079	0.130	0.500	3.00	SAT490750-5	SAT490750-5A	231390	231444
1.0-5	0.490	1.000	0.079	0.130	0.500	3.00	SAT4901000-5	SAT4901000-5A	231372	231426
1.0-5	0.490	2.000	0.079	0.130	0.500	3.00	SAT4902000-5	SAT4902000-5A	231381	231435

[Go to Single Point Tools Overview](#)

SOLID CARBIDE BORING BAR FEED AND SPEED CHART

MATERIAL	HB/Rc	SPEED (SFM)		FEED IPR	CUTTING CONDITIONS					
		UNCOATED	ALTiN+		TOOL DIAMETER					
					.015-.045	.050-.100	.110-.160	.180-.230	.290-.320	.360+
					MAX DOC	MAX DOC	MAX DOC	MAX DOC	MAX DOC	MAX DOC
CAST IRON	160 HB	75-200	200-550	.0005-.010	0.006	0.008	0.010	0.014	0.020	0.031
CARBON STEEL	18 Rc	75-200	200-450	.0005-.007	0.003	0.005	0.006	0.008	0.012	0.017
ALLOY STEEL	20 Rc	75-200	200-425	.0005-.007	0.003	0.004	0.005	0.007	0.010	0.015
TOOL STEEL	25 Rc	75-175	175-300	.0005-.005	0.002	0.003	0.004	0.006	0.008	0.012
300 STAINLESS STEEL	150 HB	75-175	175-350	.0005-.005	0.003	0.003	0.004	0.006	0.008	0.013
400 STAINLESS STEEL	195 HB	75-210	130-420	.0005-.005	0.002	0.003	0.004	0.006	0.008	0.012
HIGH TEMP ALLOY (Ni & Co BASE)	20 Rc	50-130	130-300	.0005-.004	0.002	0.003	0.003	0.005	0.007	0.010
TITANIUM	25 Rc	50-120	120-275	.0005-.005	0.003	0.004	0.005	0.006	0.009	0.014
HEAT TREATED ALLOYS (38-45Rc)	40 Rc	50-100	100-200	.0005-.005	0.002	0.002	0.003	0.004	0.006	0.009
ALUMINUM	100 HB	75-250	250-750	.0005-.015	0.011	0.015	0.019	0.026	0.038	0.056
BRASS, ZINC	80 HB	75-300	250-650	.001-.010	0.009	0.012	0.015	0.021	0.030	0.045

SFM = Surface Feet Per Minute DOC = Depth of Cut IPR = Inches Per Revolution

Starting parameters only. Length-to-diameter ratios, setup, and machine rigidity may affect performance.

$$\text{SFM} = .262 \times \text{DIAMETER} \times \text{RPM}$$

$$\text{RPM} = 3.82 \times \text{SFM} \div \text{DIAMETER}$$

$$\text{IPM} = \text{FPT} \times \text{Number of Teeth} \times \text{RPM}$$

$$\text{Meters/Min} = \text{SFM} \times .3048$$

$$\text{Millimeters/Rev} = \text{IPR} \times 25.40$$

SOLID CARBIDE BORING TROUBLESHOOTING

PROBLEM	CAUSE	SOLUTION
RAPID FLANK WEAR	CUTTING CONDITIONS	Check for excessive speed and feed - See chart.
	TOOL	Select a coated tool.
	PART	Make sure prior operation did not work harden the metal.
BUILT-UP EDGE	TOOL	Select a coated tool.
	CUTTING FORCE	Check for excessive feed rate (IPR) - See chart.
	HEAT	Use the SCT coolant holder. If coolant is not available, use shop air and a coated tool.
CORNER BREAKAGE	CUTTING CONDITIONS	Check for excessive feed and speed and depth of cut - see chart.
	TOOL	Select a tool with a radius. A radius is stronger than a sharp corner.
	PART	Check the drilled hole.
SURFACE TOO ROUGH	CUTTING CONDITIONS	Check for excessive feed rate (IPR) - See chart.
	BUILT-UP EDGE	See above (Built-Up Edge).
CHATTER	SET UP	Set tool above center. Reduce the overhang ratio. Clamping length should be at least 3x the boring bar diameter. Change the speed of the machine. Speed change may break up harmonics and reduce chatter.
	BORING BAR	Select the largest diameter boring bar that will bore the required diameter.
TAPER SMALLER IN BACK	CHIP PACKING	If the boring bar is too large to allow chips to evacuate, then the chips may pack on the tool and cause the bar to deflect away from the bore.
	PROGRAM	If the taper is consistent, then the program can be altered to bore a taper in opposite direction resulting in a straight hole.
TAPER BIGGER IN BACK	CUTTING FORCES	Reduce forces. Deflecting bar below center causes hole to become larger.
	BUILT-UP EDGE	Built-up edge will cause the hole to become larger until the built edge breaks off, then the hole becomes smaller.
	PROGRAM	If taper is consistent, then the program can be altered to bore a taper in the opposite direction resulting in a straight hole.

GROOVING TOOL FEED AND SPEED CHART

MATERIAL	HB/Rc	SPEED (SFM)		CUTTING CONDITIONS				
				TOOL DIAMETER				
		UNCOATED	ALTiN+	.060 -0.080	.090 -.120	.187	.250-.312	.375+
				MAX FPR	MAX FPR	MAX FPR	MAX FPR	MAX FPR
CAST IRON	160 HB	75-200	200-550	0.0010	0.0012	0.0017	0.0031	0.0044
CARBON STEEL	18 Rc	75-200	200-450	0.0007	0.0008	0.0011	0.0022	0.0030
ALLOY STEEL	20 Rc	75-200	200-425	0.0006	0.0007	0.0010	0.0019	0.0026
TOOL STEEL	25 Rc	75-175	175-300	0.0005	0.0006	0.0008	0.0015	0.0022
300 STAINLESS STEEL	150 HB	75-175	75-350	0.0006	0.0007	0.0010	0.0019	0.0026
400 STAINLESS STEEL	195 HB	75-210	130-420	0.0005	0.0006	0.0008	0.0016	0.0023
HIGH TEMP ALLOY (NICKEL & COBALT BASE)	20 Rc	50-130	130-300	0.0004	0.0005	0.0007	0.0013	0.0017
TITANIUM	25 Rc	50-120	120-275	0.0005	0.0006	0.0008	0.0016	0.0022
HEAT TREATED ALLOYS (38-45Rc)	40 Rc	50-100	100-200	0.0004	0.0004	0.0006	0.0011	0.0016
ALUMINUM	100 HB	75-250	250-750	0.0022	0.0026	0.0037	0.0065	0.0085
BRASS, ZINC	80 HB	250-300	250-650	0.0018	0.0021	0.0030	0.0053	0.0079

SFM = Surface Feet Per Minute

FPR = Feed Per Revolution

Starting parameters only. Length-to-diameter ratios, setup, and machine rigidity may affect performance.

GROOVING TOOL TROUBLESHOOTING

PROBLEM	CAUSE	SOLUTION
RAPID FLANK WEAR	CUTTING CONDITIONS	Check for excessive speed - see chart.
	TOOL	Select a coated tool.
	PART	Make sure prior operation did not work harden the material.
BUILT-UP EDGE	TOOL	Select a coated tool.
	CUTTING FORCE	Check for excessive speed rate (IPR) - see chart.
	HEAT	Use the SCT coolant holder. If coolant is not available, use shop air and a coated tool.
CHATTER	CUTTING CONDITIONS	Reduce RPM and increase feed rate within the feed and speed chart parameters.
	CLAMPING	Clamping length should be a minimum of 3x the shank diameter in the tool holder. Check tool holding rigidity.
	TOOL	Hone cutting edge. A light hone (0.0001-0.0003 inch) will help keep force constant.
TOOL BREAKAGE	CUTTING CONDITIONS	Check for excessive feed rate (IPR) - see chart.
	CHIP PACKING	Stagger - Peck grooving.

SINGLE POINT THREADING TECHNICAL CHART

MATERIAL	HB/Rc	SPEED (SFM)		FIRST PASS DEPTH					
		UNCOATED	ALTiN+	TOOL DIAMETER					
				.040-.050	.060-.092	.120-.152	.180-.232	.290-.362	.373+
CAST IRON	160 HB	75-200	200-550	0.003	0.004	0.005	0.007	0.008	0.009
CARBON STEEL	18 Rc	75-200	200-450	0.003	0.005	0.006	0.007	0.008	0.009
ALLOY STEEL	20 Rc	75-200	200-425	0.003	0.004	0.005	0.006	0.007	0.008
TOOL STEEL	25 Rc	75-175	175-300	0.002	0.003	0.004	0.005	0.006	0.007
300 STAINLESS STEEL	150 HB	75-175	175-350	0.003	0.003	0.004	0.005	0.006	0.007
400 STAINLESS STEEL	195 HB	75-210	130-420	0.003	0.004	0.005	0.006	0.006	0.007
HIGH TEMP ALLOY (NICKEL & COBALT BASE)	20 Rc	50-130	130-300	0.002	0.003	0.003	0.004	0.005	0.005
TITANIUM	25 Rc	50-100	120-275	0.003	0.003	0.004	0.005	0.006	0.007
HEAT TREATED ALLOYS (38-45Rc)	40 Rc	50-100	100-200	0.002	0.002	0.003	0.004	0.004	0.005
ALUMINUM	100 HB	75-250	200-750	0.004	0.005	0.007	0.008	0.010	0.011
BRASS, ZINC	80 HB	75-300	250-650	0.003	0.005	0.006	0.007	0.008	0.009

Parameters are a starting point based on machinability rating at hardness listed.
Check machinability rating of the material to be machined and adjust First Pass Depth.

Helpful Formulas and Information

$$\text{PITCH} = \frac{1}{\text{TPI}}$$

TPI = Threads Per Inch

ACME Thread Depth = Pitch × 0.5

Stub ACME Thread Depth = Pitch × 0.3

NPT Pipe Thread Depth = Pitch × 0.76

Internal 60° Thread Depth = Pitch × 0.54

Feed Rate = Pitch × Number of Thread Starts

Minimum Depth per Pass should not be less than 0.0003

Threads not ending in a relief need at least one thread pitch length of pullout

Make sure feed rate calculation does not exceed the maximum feed rate of the machine

SINGLE POINT THREADING TROUBLESHOOTING

PROBLEM	CAUSE	SOLUTION
RAPID FLANK WEAR	CUTTING CONDITIONS	Check for excessive speed - see chart.
	PART	Make sure prior operation did not work harden the material.
	TOOL	Select a coated tool.
BUILT-UP EDGE	TOOL	Select a coated tool.
	CUTTING FORCE	Increase the number of passes.
	HEAT	Use the SCT coolant holder. If coolant is not available, use shop air and a coated tool.
CORNER BREAKAGE	CUTTING CONDITIONS	Reduce the depth-of-cut on the first pass.
	PROGRAM	If there is no thread relief, withdraw the tool on an angle.
	PART	End in thread relief.
CHIPS WRAPPING AROUND TOOL	TOOL	Use a tool that is at least 30% smaller than the hole diameter.

RADIAL INFEEED

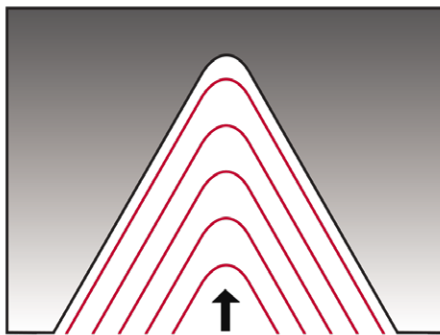

NOT RECOMMENDED

MODIFIED FLANK

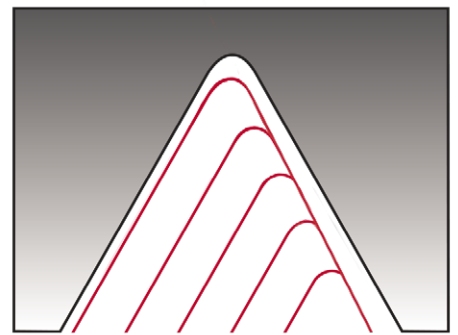

PREFERRED METHOD

Radial Infeed is not recommended. Modified flank at 1° is recommended.

For unfavorable length-to-diameter ratios or difficult-to-machine materials, the number of passes will need to be increased up to 40% more.

Depth of cut per pass should not be less than 0.0003 inch.

SINGLE POINT CBN & PCD TECHNICAL & APPLICATION

PCD TIPPED TOOL INFORMATION

SCT PCD tools and inserts are excellent for continuous cutting of a wide range of non-ferrous and non-metal materials. The products are precision ground for machining to sub-micron finishes with maximum tool life. PCD allows for higher cutting speeds with longer tool life.

SINGLE POINT TOOLS
TECH INFO

MATERIAL	BHN/Rc	SPEED RANGE (SFM)	FEED IPR	SINGLE POINT PCD TIPPED BARS			
				TOOL DIAMETER			
				.120-160 MAX DOC	.180-.230 MAX DOC	.290-.320 MAX DOC	.360+ MAX DOC
LOW SILICON ALUMINUM	225-350 BHN	1000-5000	.001-.007	0.015	0.021	0.03	0.045
HIGH SILICON ALUMINUM	270-425 BHN	600-3000	.001-.007	0.015	0.021	0.03	0.045
METAL MATRIX COMPOSITIES	N/A	500-2000	.001-.007	0.008	0.012	0.02	0.03
COPPER ALLOYS, BRASS, BRONZE	80-120 BHN	750-3500	.001-.007	0.015	0.021	0.03	0.045
PRESINTERED TUNGSTEN CARBIDE	140-300 BHN	100-350	.001-.005	0.003	0.005	0.007	0.012
ACRYLICS	N/A	700-1500	.001-.007	0.015	0.021	0.03	0.045
FIBERGLASS	N/A	600-1000	.001-.007	0.012	0.02	0.03	0.045
GRAPHITES	N/A	600-1000	.001-.007	0.015	0.021	0.03	0.045
NYLON, PLASTIC	N/A	700-1500	.001-.007	0.015	0.021	0.03	0.045
HARD RUBBER	N/A	500-2500	.001-.007	0.015	0.021	0.03	0.045

APPLICATION GUIDELINES
Make sure the machine and setup is rigid and solid. Chatter will cause chipping.
Tool height when boring should be slightly above center. Tool deflection will put the tool on center.
Do not stop the machine with the tool in cut. This will result in tool breakage.
Use of coolant will reduce heat and improve surface finish.
Do not contact the tool to a hard surface prior to the machining process- this will cause chipping.
Higher speeds minimize tool buildup.
Depth of cut should not exceed 70% of PCD tip length.

As the DOC decreases the feed rate can increase DOC = Depth of Cut SFM = Surface Feet per Minute

CBN TIPPED TOOL INFORMATION

SCT CBN tools and inserts are excellent for continuous cutting of a wide range of hardened steels, powdered metals, cast irons and super alloys. The products are precision ground with hones for machining to sub-micron finishes with maximum tool life. CBN tipped tools and inserts can take the place of grinding.

MATERIAL	BHN/Rc	SPEED RANGE (SFM)	FEED IPR	SINGLE POINT CBN TIPPED BARS			
				TOOL DIAMETER			
				.120-160 MAX DOC	.180-.230 MAX DOC	.290-.320 MAX DOC	.360+ MAX DOC
HEAT TREATED ALLOY	45-60Rc	200-600	.001-.005	0.003	0.004	0.006	0.009
TOOL STEEL	45-60Rc	200-600	.001-.005	0.003	0.004	0.006	0.009
NODULAR IRON	N/A	600-1500	.001-.005	0.006	0.01	0.02	0.03
PEARLITIC IRON	220-240BHN	600-2500	.001-.007	0.006	0.01	0.02	0.03
WHITE/CHILLED IRON	54-60Rc	200-500	.001-.005	0.005	0.008	0.012	0.015
SUPER ALLOY Ni BASE	240-475 BHN	200-800	.001-.005	0.003	0.004	0.006	0.025
COBOLT BASED ALLOY, STELLITE	45-55Rc	200-500	.001-.005	0.003	0.004	0.006	0.009
INCONELS	45-55Rc	200-500	.001-.005	0.003	0.004	0.006	0.009

APPLICATION GUIDELINES
Make sure the machine and setup is rigid and solid. Chatter will cause chipping
Tool height when boring should be slightly above center. Tool deflection will put the tool on center.
Do not stop the machine with the tool in cut. This will result in tool breakage.
Coolant use is not advised as it could cause thermal cracking.
Do not contact the tool to a hard surface prior to the machining process. This will cause chipping.
Depth of cut should not exceed 30% of CBN tip length.

As the DOC decreases the feed rate can increase DOC = Depth of Cut SFM = Surface Feet per Minute



INDEXABLE TOOLING

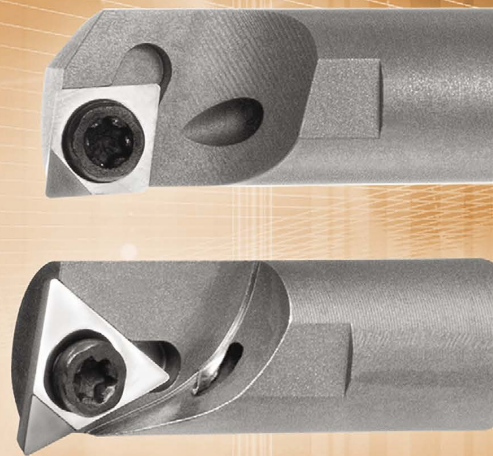

Right Hand Indexable Bars
Left Hand Indexable Bars
Diamond Shaped Inserts
Triangle Shaped Inserts
Chip Control Inserts
CBN/PCD Inserts
Coolant Through Bars

INDEXABLE BORING PRODUCT OVERVIEW

SCT indexable boring bars consist of micro grain carbide shanks with heat-treated steel heads. Select tools are crafted with a unique top cut which strengthens the pocket by 40% and directs chips away from the cut zone. Bars are stocked with or without flats and are available with or without coolant holes. Inserts are available uncoated or in ALTiN+ coating and are available as diamond-shaped or triangle-shaped. Other insert options include PCD-tipped or CBN-tipped inserts. Right-handed bars are compatible with chip control inserts. Technical information is available on pages 86-88.

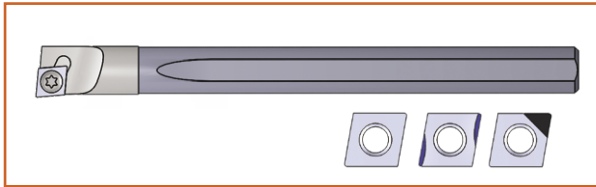

DIAMOND INSERT INDEXABLE BARS

- 3/16" Right or Left-Hand Bars.... p.75
- 1/4" Right or Left-Hand Bars..... p.76
- 5/16" Right or Left-Hand Bars.... p.78
- 3/8" Right or Left-Hand Bars..... p.80
- 1/2" Right or Left-Hand Bars..... p.82

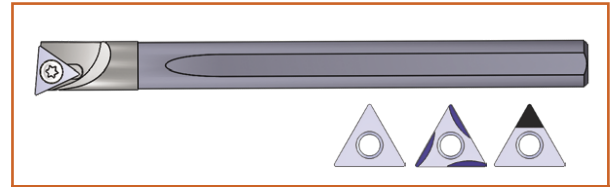

TRIANGLE INSERT INDEXABLE BARS

- 1/4" Right or Left-Hand Bars..... p.77
- 5/16" Right or Left-Hand Bars.... p.79
- 3/8" Right or Left-Hand Bars..... p.81
- 1/2" Right or Left-Hand Bars..... p.83

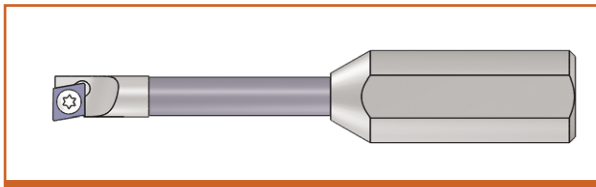

DIAMOND INSERT STEP BARS

- Diamond Right-Hand Step Bars.... p.84

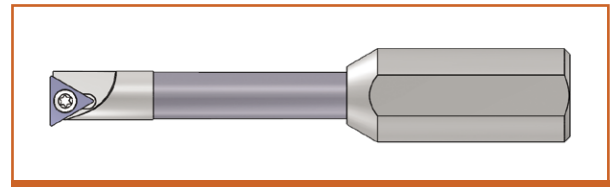

TRIANGLE INSERT STEP BARS

- Triangle Right-Hand Step Bars.... p.85

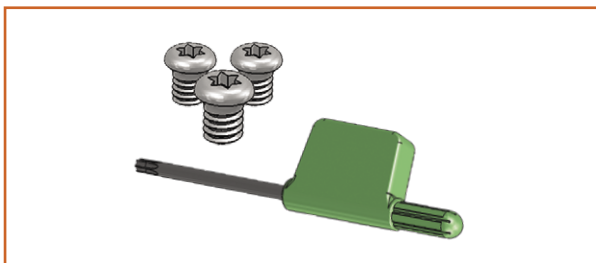

INDEXABLE BAR ACCESORIES

- Screws and Keys..... p.84

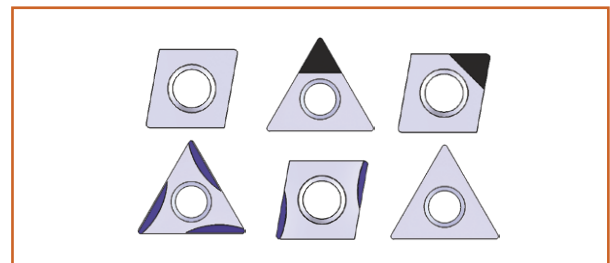

CARBIDE INSERTS

Inserts and compatible bars are listed on the same page for your convenience. Flat top or chip control inserts are sold in packs of five. PCD or CBN inserts are sold individually.

INDEXABLE BORING TECHNICAL INFORMATION PAGES 86-88

INDEXABLE BORING BAR AND INSERTS

3/16" CARBIDE SHANK - DIAMOND SHAPED INSERTS

EACH BAR COMES WITH ONE SCREW AND ONE KEY. INSERTS SOLD SEPARATELY.

BAR WITH COOLANT HOLE

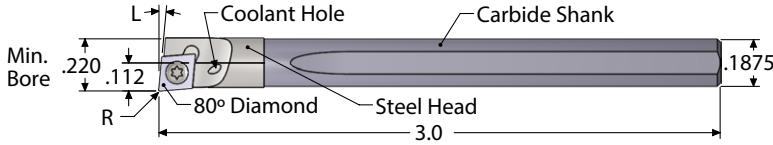

"L" ANGLE	BAR FLAT	INSERT TYPE	RH/LH	ORDER #		EDP #	
				COOLANT THROUGH	COOLANT THROUGH		
5°	NONE	ACD5	RIGHT	ADBC187R5R		300422	
5°	FLAT	ACD5	RIGHT	ADBC187F5R		300410	
0°	NONE	ACD5	RIGHT	ADBC187R0R		300416	
0°	FLAT	ACD5	RIGHT	ADBC187F0R		300404	
5°	NONE	ACD5	LEFT	ADBC187R5L		300419	
5°	FLAT	ACD5	LEFT	ADBC187F5L		300407	
0°	NONE	ACD5	LEFT	ADBC187R0L		300413	
0°	FLAT	ACD5	LEFT	ADBC187F0L		300401	

CARBIDE INSERTS

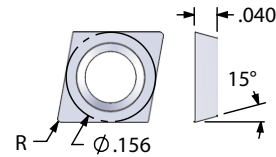

80° DIAMOND FLAT TOP

FIVE SCREWS	"R" CORNER RADIUS	ORDER #		EDP #	
		FIVE UNCOATED	FIVE ALTiN+	FIVE UNCOATED	FIVE ALTiN+
AT6+	0.003	ACD5031	ACD5031E	301001	301008
AT6+	0.007	ACD5071	ACD5071E	301015	301029
AT6+	0.015	ACD5151	ACD5151E	301057	301071

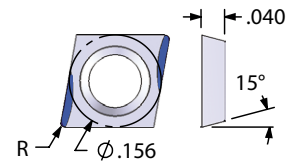

80° DIAMOND CHIP CONTROL
RIGHT HAND ONLY

FIVE SCREWS	"R" CORNER RADIUS	ORDER #		EDP #	
		FIVE UNCOATED	FIVE ALTiN+	FIVE UNCOATED	FIVE ALTiN+
AT6+	0.007	ACD507L3	ACD507L3E	301044	301051
AT6+	0.015	ACD515L3	ACD515L3E	301086	301093

BAR WITHOUT COOLANT HOLE

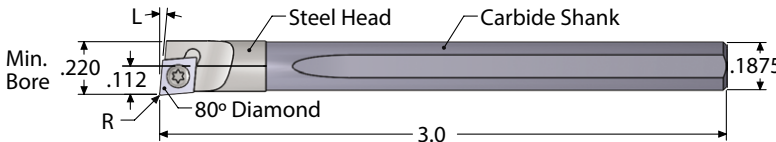

"L" ANGLE	BAR FLAT	INSERT TYPE	RH/LH	ORDER #		EDP #	
				NO COOLANT HOLE	NO COOLANT HOLE		
5°	NONE	ACD5	RIGHT	ACBC187R5R		300022	
5°	FLAT	ACD5	RIGHT	ACBC187F5R		300010	
0°	NONE	ACD5	RIGHT	ACBC187R0R		300016	
0°	FLAT	ACD5	RIGHT	ACBC187F0R		300004	
5°	NONE	ACD5	LEFT	ACBC187R5L		300019	
5°	FLAT	ACD5	LEFT	ACBC187F5L		300007	
0°	NONE	ACD5	LEFT	ACBC187R0L		300013	
0°	FLAT	ACD5	LEFT	ACBC187F0L		300001	

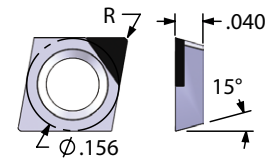

80° DIAMOND CBN/PCD TIPPED

ONE SCREW	"R" CORNER RADIUS	ORDER #		EDP #	
		ONE CBN	ONE PCD	ONE CBN	ONE PCD
AT6+	0.007	ACD5071CBN2	ACD5071PCD	301022	301036
AT6+	0.015	ACD5151CBN2	ACD5151PCD	301064	301078

Inserts and compatible bars are listed together.

[Go to Indexable Boring Overview](#)

INDEXABLE BORING BAR AND INSERTS

1/4" CARBIDE SHANK - DIAMOND SHAPED INSERTS

EACH BAR COMES WITH ONE SCREW AND ONE KEY. INSERTS SOLD SEPARATELY.

BAR WITH COOLANT HOLE

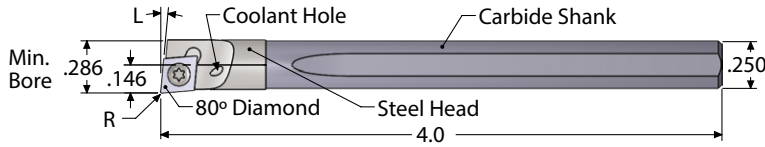

"L" ANGLE	BAR FLAT	INSERT TYPE	RH/LH	ORDER #	EDP #
				COOLANT THROUGH	COOLANT THROUGH
5°	NONE	ACD5	RIGHT	ADBC250R5R	300446
5°	FLAT	ACD5	RIGHT	ADBC250F5R	300434
0°	NONE	ACD5	RIGHT	ADBC250R0R	300440
0°	FLAT	ACD5	RIGHT	ADBC250F0R	300428
5°	NONE	ACD5	LEFT	ADBC250R5L	300443
5°	FLAT	ACD5	LEFT	ADBC250F5L	300431
0°	NONE	ACD5	LEFT	ADBC250R0L	300437
0°	FLAT	ACD5	LEFT	ADBC250F0L	300425

CARBIDE INSERTS

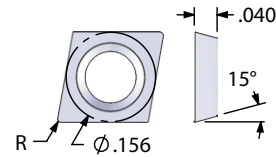

80° DIAMOND FLAT TOP

FIVE SCREWS	"R" CORNER RADIUS	ORDER #		EDP #	
		FIVE UNCOATED	FIVE ALTiN+	FIVE UNCOATED	FIVE ALTiN+
AT6+	0.003	ACD5031	ACD5031E	301001	301008
AT6+	0.007	ACD5071	ACD5071E	301015	301029
AT6+	0.015	ACD5151	ACD5151E	301057	301071

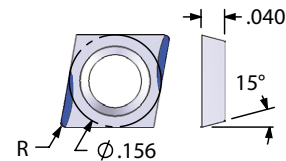

80° DIAMOND CHIP CONTROL
RIGHT HAND ONLY

FIVE SCREWS	"R" CORNER RADIUS	ORDER #		EDP #	
		FIVE UNCOATED	FIVE ALTiN+	FIVE UNCOATED	FIVE ALTiN+
AT6+	0.007	ACD507L3	ACD507L3E	301044	301051
AT6+	0.015	ACD515L3	ACD515L3E	301086	301093

BAR WITHOUT COOLANT HOLE

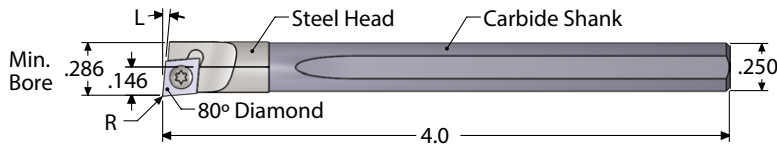

"L" ANGLE	BAR FLAT	INSERT TYPE	RH/LH	ORDER #	EDP #
				NO COOLANT HOLE	NO COOLANT HOLE
5°	NONE	ACD5	RIGHT	ACBC250R5R	300070
5°	FLAT	ACD5	RIGHT	ACBC250F5R	300058
0°	NONE	ACD5	RIGHT	ACBC250R0R	300064
0°	FLAT	ACD5	RIGHT	ACBC250F0R	300052
5°	NONE	ACD5	LEFT	ACBC250R5L	300067
5°	FLAT	ACD5	LEFT	ACBC250F5L	300055
0°	NONE	ACD5	LEFT	ACBC250R0L	300061
0°	FLAT	ACD5	LEFT	ACBC250F0L	300049

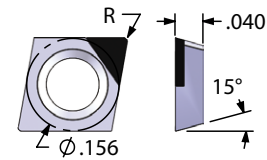

80° DIAMOND CBN/PCD TIPPED

ONE SCREW	"R" CORNER RADIUS	ORDER #		EDP #	
		ONE CBN	ONE PCD	ONE CBN	ONE PCD
AT6+	0.007	ACD5071CBN2	ACD5071PCD	301022	301036
AT6+	0.015	ACD5151CBN2	ACD5151PCD	301064	301078

Inserts and compatible bars are listed together.

[Go to Indexable Boring Overview](#)

INDEXABLE BORING BAR AND INSERTS

1/4" CARBIDE SHANK - TRIANGLE SHAPED INSERTS

EACH BAR COMES WITH ONE SCREW AND ONE KEY. INSERTS SOLD SEPARATELY.

BAR WITH COOLANT HOLE

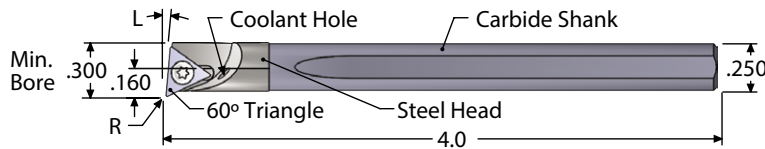

"L" ANGLE	BAR FLAT	INSERT TYPE	RH/LH	ORDER #		EDP #	
				COOLANT THROUGH	COOLANT THROUGH	COOLANT THROUGH	COOLANT THROUGH
5°	NONE	ATD5	RIGHT	ABDT250R5R		300470	
5°	FLAT	ATD5	RIGHT	ABDT250F5R		300458	
0°	NONE	ATD5	RIGHT	ABDT250R0R		300464	
0°	FLAT	ATD5	RIGHT	ABDT250F0R		300452	
5°	NONE	ATD5	LEFT	ABDT250R5L		300467	
5°	FLAT	ATD5	LEFT	ABDT250F5L		300455	
0°	NONE	ATD5	LEFT	ABDT250R0L		300461	
0°	FLAT	ATD5	LEFT	ABDT250F0L		300449	

BAR WITHOUT COOLANT HOLE

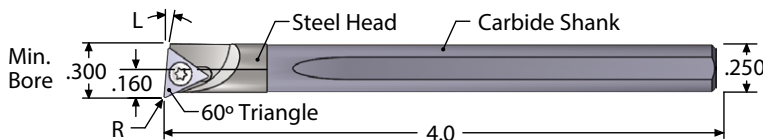

"L" ANGLE	BAR FLAT	INSERT TYPE	RH/LH	ORDER #		EDP #	
				NO COOLANT HOLE	NO COOLANT HOLE	NO COOLANT HOLE	NO COOLANT HOLE
5°	NONE	ATD5	RIGHT	ACBT250R5R		300046	
5°	FLAT	ATD5	RIGHT	ACBT250F5R		300034	
0°	NONE	ATD5	RIGHT	ACBT250R0R		300040	
0°	FLAT	ATD5	RIGHT	ACBT250F0R		300028	
5°	NONE	ATD5	LEFT	ACBT250R5L		300043	
5°	FLAT	ATD5	LEFT	ACBT250F5L		300031	
0°	NONE	ATD5	LEFT	ACBT250R0L		300037	
0°	FLAT	ATD5	LEFT	ACBT250F0L		300025	

CARBIDE INSERTS

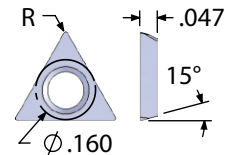

60° TRIANGLE FLAT TOP

FIVE SCREWS	"R" CORNER RADIUS	ORDER #		EDP #	
		FIVE UNCOATED	FIVE ALTiN+	FIVE UNCOATED	FIVE ALTiN+
AT6+	0.003	ATD5031	ATD5031E	301099	301106
AT6+	0.007	ATD5071	ATD5071E	301113	301127
AT6+	0.015	ATD5151	ATD5151E	301155	301169

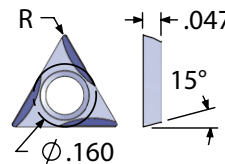

60° TRIANGLE CHIP CONTROL
RIGHT HAND ONLY

FIVE SCREWS	"R" CORNER RADIUS	ORDER #		EDP #	
		FIVE UNCOATED	FIVE ALTiN+	FIVE UNCOATED	FIVE ALTiN+
AT6+	0.007	ATD507L3	ATD507L3E	301142	301149
AT6+	0.015	ATD515L3	ATD515L3E	301184	301191

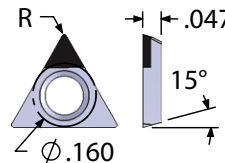

60° TRIANGLE CBN/PCD TIPPED

ONE SCREW	"R" CORNER RADIUS	ORDER #		EDP #	
		ONE CBN	ONE PCD	ONE CBN	ONE PCD
AT6+	0.007	ATD5071CBN2	ATD5071PCD	301120	301134
AT6+	0.015	ATD5151CBN2	ATD5151PCD	301162	301176

Inserts and compatible bars are listed together.

[Go to Indexable Boring Overview](#)

INDEXABLE BORING BAR AND INSERTS

5/16" CARBIDE SHANK - DIAMOND SHAPED INSERTS

EACH BAR COMES WITH ONE SCREW AND ONE KEY. INSERTS SOLD SEPARATELY.

BAR WITH COOLANT HOLE

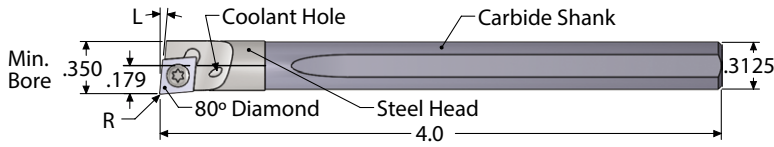

"L" ANGLE	BAR FLAT	INSERT TYPE	RH/LH	ORDER #	EDP #
				COOLANT THROUGH	COOLANT THROUGH
5°	NONE	ACD5	RIGHT	ADBC312R5R	300518
5°	FLAT	ACD5	RIGHT	ADBC312F5R	300506
0°	NONE	ACD5	RIGHT	ADBC312R0R	300512
0°	FLAT	ACD5	RIGHT	ADBC312F0R	300500
5°	NONE	ACD5	LEFT	ADBC312R5L	300515
5°	FLAT	ACD5	LEFT	ADBC312F5L	300503
0°	NONE	ACD5	LEFT	ADBC312R0L	300509
0°	FLAT	ACD5	LEFT	ADBC312F0L	300497

CARBIDE INSERTS

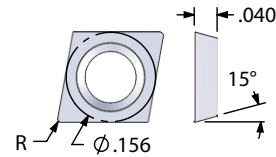

80° DIAMOND FLAT TOP

FIVE SCREWS	"R" CORNER RADIUS	ORDER #		EDP #	
		FIVE UNCOATED	FIVE ALTiN+	FIVE UNCOATED	FIVE ALTiN+
AT6+	0.003	ACD5031	ACD5031E	301001	301008
AT6+	0.007	ACD5071	ACD5071E	301015	301029
AT6+	0.015	ACD5151	ACD5151E	301057	301071

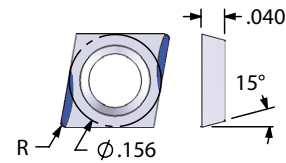

80° DIAMOND CHIP CONTROL
RIGHT HAND ONLY

FIVE SCREWS	"R" CORNER RADIUS	ORDER #		EDP #	
		FIVE UNCOATED	FIVE ALTiN+	FIVE UNCOATED	FIVE ALTiN+
AT6+	0.007	ACD507L3	ACD507L3E	301044	301051
AT6+	0.015	ACD515L3	ACD515L3E	301086	301093

BAR WITHOUT COOLANT HOLE

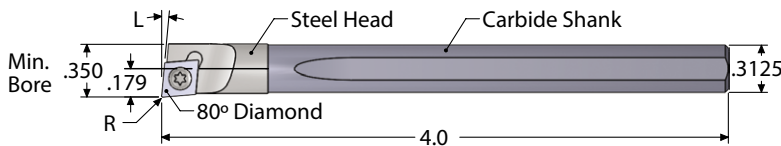

"L" ANGLE	BAR FLAT	INSERT TYPE	RH/LH	ORDER #	EDP #
				NO COOLANT HOLE	NO COOLANT HOLE
5°	NONE	ACD5	RIGHT	ACBC312R5R	300094
5°	FLAT	ACD5	RIGHT	ACBC312F5R	300082
0°	NONE	ACD5	RIGHT	ACBC312R0R	300088
0°	FLAT	ACD5	RIGHT	ACBC312F0R	300076
5°	NONE	ACD5	LEFT	ACBC312R5L	300091
5°	FLAT	ACD5	LEFT	ACBC312F5L	300079
0°	NONE	ACD5	LEFT	ACBC312R0L	300085
0°	FLAT	ACD5	LEFT	ACBC312F0L	300073

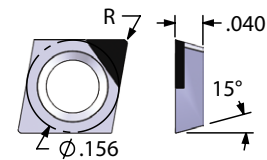

80° DIAMOND CBN/PCD TIPPED

ONE SCREW	"R" CORNER RADIUS	ORDER #		EDP #	
		ONE CBN	ONE PCD	ONE CBN	ONE PCD
AT6+	0.007	ACD5071CBN2	ACD5071PCD	301022	301036
AT6+	0.015	ACD5151CBN2	ACD5151PCD	301064	301078

Inserts and compatible bars are listed together.

[Go to Indexable Boring Overview](#)

INDEXABLE BORING BAR AND INSERTS

5/16" CARBIDE SHANK - TRIANGLE SHAPED INSERTS

EACH BAR COMES WITH ONE SCREW AND ONE KEY. INSERTS SOLD SEPARATELY.

BAR WITH COOLANT HOLE

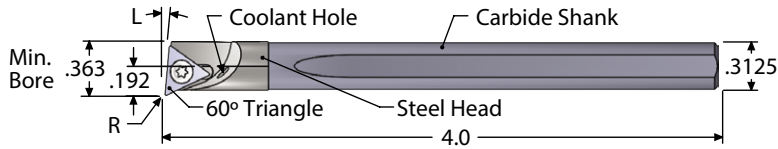

"L" ANGLE	BAR FLAT	INSERT TYPE	RH/LH	ORDER #		EDP #	
				COOLANT THROUGH	COOLANT THROUGH		
5°	NONE	ATD5	RIGHT	ADBT312R5R		300494	
5°	FLAT	ATD5	RIGHT	ADBT312F5R		300482	
0°	NONE	ATD5	RIGHT	ADBT312R0R		300488	
0°	FLAT	ATD5	RIGHT	ADBT312F0R		300476	
5°	NONE	ATD5	LEFT	ADBT312R5L		300491	
5°	FLAT	ATD5	LEFT	ADBT312F5L		300479	
0°	NONE	ATD5	LEFT	ADBT312R0L		300485	
0°	FLAT	ATD5	LEFT	ADBT312F0L		300473	

CARBIDE INSERTS

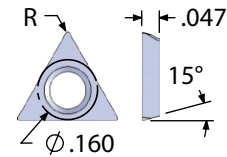

60° TRIANGLE FLAT TOP

FIVE SCREWS	"R" CORNER RADIUS	ORDER #		EDP #	
		FIVE UNCOATED	FIVE ALTiN+	FIVE UNCOATED	FIVE ALTiN+
AT6+	0.003	ATD5031	ATD5031E	301099	301106
AT6+	0.007	ATD5071	ATD5071E	301113	301127
AT6+	0.015	ATD5151	ATD5151E	301155	301169

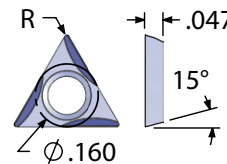

60° TRIANGLE CHIP CONTROL
RIGHT HAND ONLY

FIVE SCREWS	"R" CORNER RADIUS	ORDER #		EDP #	
		FIVE UNCOATED	FIVE ALTiN+	FIVE UNCOATED	FIVE ALTiN+
AT6+	0.007	ATD507L3	ATD507L3E	301142	301149
AT6+	0.015	ATD515L3	ATD515L3E	301184	301191

BAR WITHOUT COOLANT HOLE

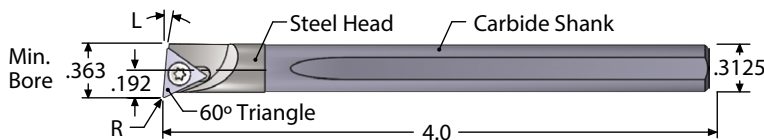

"L" ANGLE	BAR FLAT	INSERT TYPE	RH/LH	ORDER #		EDP #	
				NO COOLANT HOLE	NO COOLANT HOLE		
5°	NONE	ATD5	RIGHT	ACBT312R5R		300115	
5°	FLAT	ATD5	RIGHT	ACBT312F5R		300103	
0°	NONE	ATD5	RIGHT	ACBT312R0R		300109	
0°	FLAT	ATD5	RIGHT	ACBT312F0R		300097	
5°	NONE	ATD5	LEFT	ACBT312R5L		300112	
5°	FLAT	ATD5	LEFT	ACBT312F5L		300100	
0°	NONE	ATD5	LEFT	ACBT312R0L		300106	
0°	FLAT	ATD5	LEFT	ACBT312F0L		300118	

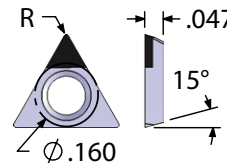

60° TRIANGLE CBN/PCD TIPPED

ONE SCREW	"R" CORNER RADIUS	ORDER #		EDP #	
		ONE CBN	ONE PCD	ONE CBN	ONE PCD
AT6+	0.007	ATD5071CBN2	ATD5071PCD	301120	301134
AT6+	0.015	ATD5151CBN2	ATD5151PCD	301162	301176

Inserts and compatible bars are listed together.

[Go to Indexable Boring Overview](#)

INDEXABLE BORING BAR AND INSERTS

3/8" CARBIDE SHANK - DIAMOND SHAPED INSERTS

EACH BAR COMES WITH ONE SCREW AND ONE KEY. INSERTS SOLD SEPARATELY.

BAR WITH COOLANT HOLE

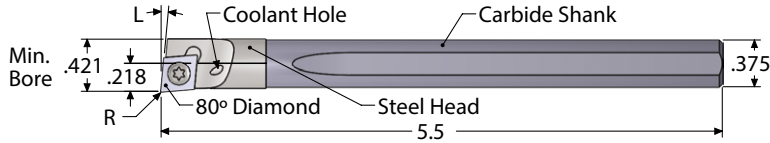

"L" ANGLE	BAR FLAT	INSERT TYPE	RH/LH	ORDER #		EDP #	
				COOLANT THROUGH	COOLANT THROUGH		
5°	NONE	ACP2	RIGHT	ADBC375R5R		300542	
5°	FLAT	ACP2	RIGHT	ADBC375F5R		300530	
0°	NONE	ACP2	RIGHT	ADBC375R0R		300536	
0°	FLAT	ACP2	RIGHT	ADBC375F0R		300524	
5°	NONE	ACP2	LEFT	ADBC375R5L		300539	
5°	FLAT	ACP2	LEFT	ADBC375F5L		300527	
0°	NONE	ACP2	LEFT	ADBC375R0L		300533	
0°	FLAT	ACP2	LEFT	ADBC375F0L		300521	

CARBIDE INSERTS

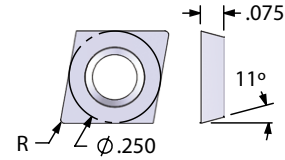

80° DIAMOND FLAT TOP

FIVE SCREWS	"R" CORNER RADIUS	ORDER #		EDP #	
		FIVE UNCOATED	FIVE ALTiN+	FIVE UNCOATED	FIVE ALTiN+
AT8+	0.003	ACP2031	ACP2031E	301197	301204
AT8+	0.007	ACP2071	ACP2071E	301211	301225
AT8+	0.015	ACP2151	ACP2151E	301253	301267

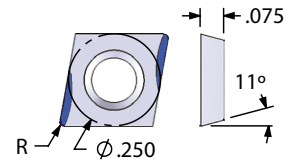

80° DIAMOND CHIP CONTROL RIGHT HAND ONLY

FIVE SCREWS	"R" CORNER RADIUS	ORDER #		EDP #	
		FIVE UNCOATED	FIVE ALTiN+	FIVE UNCOATED	FIVE ALTiN+
AT8+	0.007	ACP207L3	ACP207L3E	301240	301247
AT8+	0.015	ACP215L3	ACP215L3E	301282	301289

BAR WITHOUT COOLANT HOLE

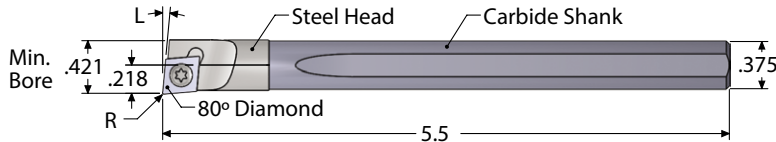

"L" ANGLE	BAR FLAT	INSERT TYPE	RH/LH	ORDER #		EDP #	
				NO COOLANT HOLE	NO COOLANT HOLE		
5°	NONE	ACP2	RIGHT	ACBC375R5R		300142	
5°	FLAT	ACP2	RIGHT	ACBC375F5R		300130	
0°	NONE	ACP2	RIGHT	ACBC375R0R		300136	
0°	FLAT	ACP2	RIGHT	ACBC375F0R		300124	
5°	NONE	ACP2	LEFT	ACBC375R5L		300139	
5°	FLAT	ACP2	LEFT	ACBC375F5L		300127	
0°	NONE	ACP2	LEFT	ACBC375R0L		300133	
0°	FLAT	ACP2	LEFT	ACBC375F0L		300121	

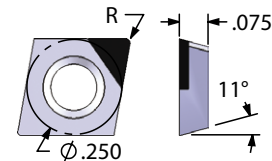

80° DIAMOND CBN/PCD TIPPED

ONE SCREW	"R" CORNER RADIUS	ORDER #		EDP #	
		ONE CBN	ONE PCD	ONE CBN	ONE PCD
AT8+	0.007	ACP2071CBN2	ACP2071PCD	301218	301232
AT8+	0.015	ACP2151CBN2	ACP2151PCD	301260	301274

Inserts and compatible bars are listed together.

[Go to Indexable Boring Overview](#)

INDEXABLE BORING BAR AND INSERTS

3/8" CARBIDE SHANK - TRIANGLE SHAPED INSERTS

EACH BAR COMES WITH ONE SCREW AND ONE KEY. INSERTS SOLD SEPARATELY.

BAR WITH COOLANT HOLE

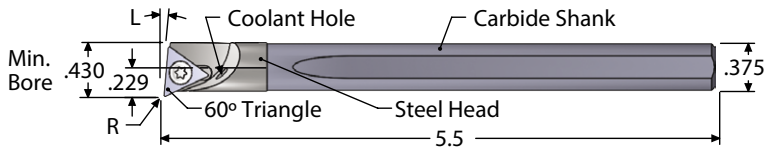

"L" ANGLE	BAR FLAT	INSERT TYPE	RH/LH	ORDER #		EDP #	
				COOLANT THROUGH	COOLANT THROUGH		
5°	NONE	ATP2	RIGHT	ADBT375R5R		300566	
5°	FLAT	ATP2	RIGHT	ADBT375F5R		300554	
0°	NONE	ATP2	RIGHT	ADBT375R0R		300560	
0°	FLAT	ATP2	RIGHT	ADBT375F0R		300548	
5°	NONE	ATP2	LEFT	ADBT375R5L		300563	
5°	FLAT	ATP2	LEFT	ADBT375F5L		300551	
0°	NONE	ATP2	LEFT	ADBT375R0L		300557	
0°	FLAT	ATP2	LEFT	ADBT375F0L		300545	

CARBIDE INSERTS

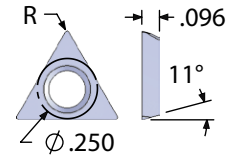

60° TRIANGLE FLAT TOP

FIVE SCREWS	"R" CORNER RADIUS	ORDER #		EDP #	
		FIVE UNCOATED	FIVE ALTiN+	FIVE UNCOATED	FIVE ALTiN+
AT8+	0.007	ATP2071	ATP2071E	301309	301323
AT8+	0.015	ATP2151	ATP2151E	301351	301365

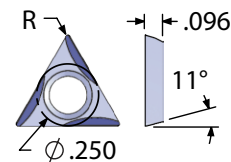

60° TRIANGLE CHIP CONTROL
RIGHT HAND ONLY

FIVE SCREWS	"R" CORNER RADIUS	ORDER #		EDP #	
		FIVE UNCOATED	FIVE ALTiN+	FIVE UNCOATED	FIVE ALTiN+
AT8+	0.007	ATP207L3	ATP207L3E	301338	301345
AT8+	0.015	ATP215L3	ATP215L3E	301380	301387

BAR WITHOUT COOLANT HOLE

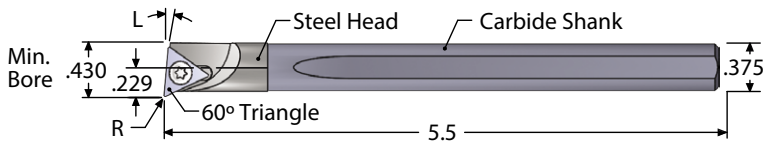

"L" ANGLE	BAR FLAT	INSERT TYPE	RH/LH	ORDER #		EDP #	
				NO COOLANT HOLE	NO COOLANT HOLE		
5°	NONE	ATP2	RIGHT	ACBT375R5R		300166	
5°	FLAT	ATP2	RIGHT	ACBT375F5R		300154	
0°	NONE	ATP2	RIGHT	ACBT375R0R		300160	
0°	FLAT	ATP2	RIGHT	ACBT375F0R		300148	
5°	NONE	ATP2	LEFT	ACBT375R5L		300163	
5°	FLAT	ATP2	LEFT	ACBT375F5L		300151	
0°	NONE	ATP2	LEFT	ACBT375R0L		300157	
0°	FLAT	ATP2	LEFT	ACBT375F0L		300145	

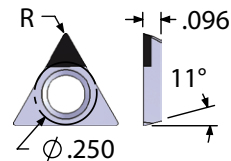

60° TRIANGLE CBN/PCD TIPPED

ONE SCREW	"R" CORNER RADIUS	ORDER #		EDP #	
		ONE CBN	ONE PCD	ONE CBN	ONE PCD
AT8+	0.007	ATP2071CBN2	ATP2071PCD	301316	301330
AT8+	0.015	ATP2151CBN2	ATP2151PCD	301358	301372

Inserts and compatible bars are listed together.

[Go to Indexable Boring Overview](#)

INDEXABLE BORING BAR AND INSERTS

1/2" CARBIDE SHANK - DIAMOND SHAPED INSERTS

EACH BAR COMES WITH ONE SCREW AND ONE KEY. INSERTS SOLD SEPARATELY.

BAR WITH COOLANT HOLE

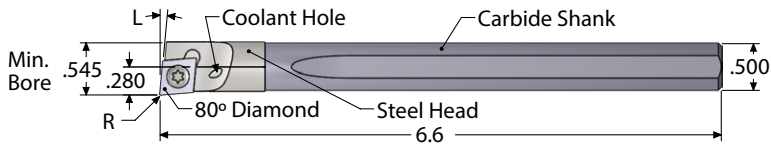

"L" ANGLE	BAR FLAT	INSERT TYPE	RH/LH	ORDER #		EDP #	
				COOLANT THROUGH	COOLANT THROUGH		
5°	NONE	ACP2	RIGHT	ADBC500R5R		300623	
5°	FLAT	ACP2	RIGHT	ADBC500F5R		300611	
0°	NONE	ACP2	RIGHT	ADBC500R0R		300617	
0°	FLAT	ACP2	RIGHT	ADBC500F0R		300605	
5°	NONE	ACP2	LEFT	ADBC500R5L		300620	
5°	FLAT	ACP2	LEFT	ADBC500F5L		300608	
0°	NONE	ACP2	LEFT	ADBC500R0L		300614	
0°	FLAT	ACP2	LEFT	ADBC500F0L		300602	

CARBIDE INSERTS

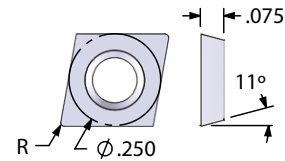

80° DIAMOND FLAT TOP

FIVE SCREWS	"R" CORNER RADIUS	ORDER #		EDP #	
		FIVE UNCOATED	FIVE ALTiN+	FIVE UNCOATED	FIVE ALTiN+
AT8+	0.003	ACP2031	ACP2031E	301197	301204
AT8+	0.007	ACP2071	ACP2071E	301211	301225
AT8+	0.015	ACP2151	ACP2151E	301253	301267

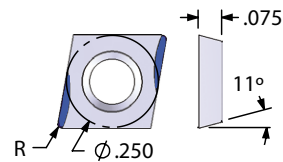

80° DIAMOND CHIP CONTROL RIGHT HAND ONLY

FIVE SCREWS	"R" CORNER RADIUS	ORDER #		EDP #	
		FIVE UNCOATED	FIVE ALTiN+	FIVE UNCOATED	FIVE ALTiN+
AT8+	0.007	ACP207L3	ACP207L3E	301240	301247
AT8+	0.015	ACP215L3	ACP215L3E	301282	301289

BAR WITHOUT COOLANT HOLE

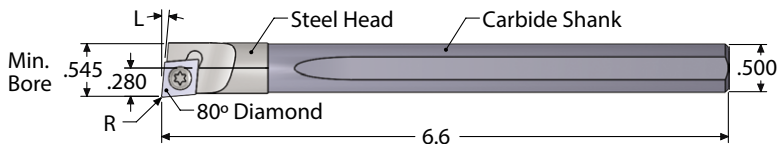

"L" ANGLE	BAR FLAT	INSERT TYPE	RH/LH	ORDER #		EDP #	
				NO COOLANT HOLE	NO COOLANT HOLE		
5°	NONE	ACP2	RIGHT	ACBC500R5R		300223	
5°	FLAT	ACP2	RIGHT	ACBC500F5R		300211	
0°	NONE	ACP2	RIGHT	ACBC500R0R		300217	
0°	FLAT	ACP2	RIGHT	ACBC500F0R		300205	
5°	NONE	ACP2	LEFT	ACBC500R5L		300220	
5°	FLAT	ACP2	LEFT	ACBC500F5L		300208	
0°	NONE	ACP2	LEFT	ACBC500R0L		300214	
0°	FLAT	ACP2	LEFT	ACBC500F0L		300202	

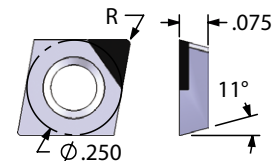

80° DIAMOND CBN/PCD TIPPED

ONE SCREW	"R" CORNER RADIUS	ORDER #		EDP #	
		ONE CBN	ONE PCD	ONE CBN	ONE PCD
AT8+	0.007	ACP2071CBN2	ACP2071PCD	301218	301232
AT8+	0.015	ACP2151CBN2	ACP2151PCD	301260	301274

Inserts and compatible bars are listed together.

[Go to Indexable Boring Overview](#)

INDEXABLE BORING BAR AND INSERTS

1/2" CARBIDE SHANK - TRIANGLE SHAPED INSERTS

EACH BAR COMES WITH ONE SCREW AND ONE KEY. INSERTS SOLD SEPARATELY.

BAR WITH COOLANT HOLE

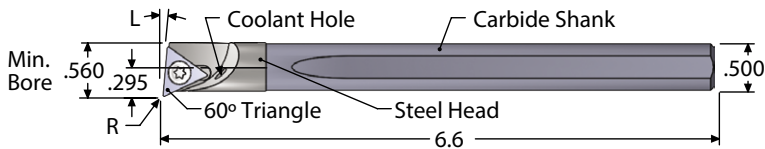

"L" ANGLE	BAR FLAT	INSERT TYPE	RH/LH	ORDER #		EDP #	
				COOLANT THROUGH	COOLANT THROUGH		
5°	NONE	ATP2	RIGHT	ABDT500R5R		300599	
5°	FLAT	ATP2	RIGHT	ABDT500F5R		300587	
0°	NONE	ATP2	RIGHT	ABDT500R0R		300593	
0°	FLAT	ATP2	RIGHT	ABDT500F0R		300581	
5°	NONE	ATP2	LEFT	ABDT500R5L		300596	
5°	FLAT	ATP2	LEFT	ABDT500F5L		300584	
0°	NONE	ATP2	LEFT	ABDT500R0L		300590	
0°	FLAT	ATP2	LEFT	ABDT500F0L		300578	

BAR WITHOUT COOLANT HOLE

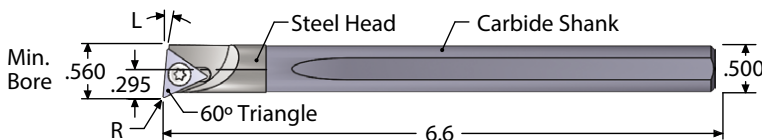

"L" ANGLE	BAR FLAT	INSERT TYPE	RH/LH	ORDER #		EDP #	
				NO COOLANT HOLE	NO COOLANT HOLE		
5°	NONE	ATP2	RIGHT	ACBT500R5R		300199	
5°	FLAT	ATP2	RIGHT	ACBT500F5R		300187	
0°	NONE	ATP2	RIGHT	ACBT500R0R		300193	
0°	FLAT	ATP2	RIGHT	ACBT500F0R		300181	
5°	NONE	ATP2	LEFT	ACBT500R5L		300196	
5°	FLAT	ATP2	LEFT	ACBT500F5L		300184	
0°	NONE	ATP2	LEFT	ACBT500R0L		300190	
0°	FLAT	ATP2	LEFT	ACBT500F0L		300178	

CARBIDE INSERTS

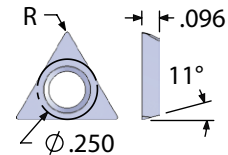

60° TRIANGLE FLAT TOP

FIVE SCREWS	"R" CORNER RADIUS	ORDER #		EDP #	
		FIVE UNCOATED	FIVE ALTiN+	FIVE UNCOATED	FIVE ALTiN+
AT8+	0.007	ATP2071	ATP2071E	301309	301323
AT8+	0.015	ATP2151	ATP2151E	301351	301365

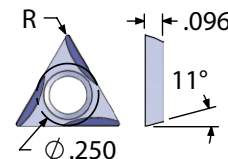

60° TRIANGLE CHIP CONTROL
RIGHT HAND ONLY

FIVE SCREWS	"R" CORNER RADIUS	ORDER #		EDP #	
		FIVE UNCOATED	FIVE ALTiN+	FIVE UNCOATED	FIVE ALTiN+
AT8+	0.007	ATP207L3	ATP207L3E	301338	301345
AT8+	0.015	ATP215L3	ATP215L3E	301380	301387

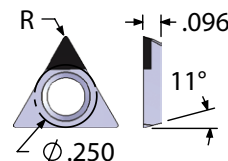

60° TRIANGLE CBN/PCD TIPPED

ONE SCREW	"R" CORNER RADIUS	ORDER #		EDP #	
		ONE CBN	ONE PCD	ONE CBN	ONE PCD
AT8+	0.007	ATP2071CBN2	ATP2071PCD	301316	301330
AT8+	0.015	ATP2151CBN2	ATP2151PCD	301358	301372

Inserts and compatible bars are listed together.

[Go to Indexable Boring Overview](#)

INDEXABLE STEP BORING BAR AND INSERTS

1/2" SHANK STEP BARS WITH DIAMOND SHAPED INSERTS

EACH BAR COMES WITH ONE SCREW AND ONE KEY. INSERTS SOLD SEPARATELY.

BAR WITH COOLANT HOLE

0.220 MINIMUM BORE

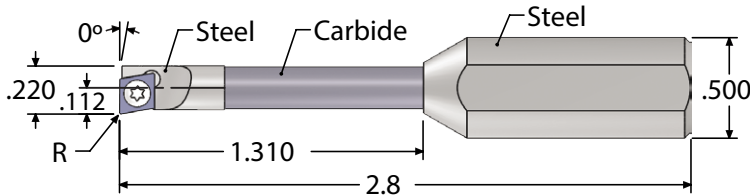

BAR FLAT	INSERT TYPE	RH/LH	ORDER #		EDP #	
			NO COOLANT HOLE	NO COOLANT HOLE	NO COOLANT HOLE	NO COOLANT HOLE
FLAT	ACD5	RIGHT	ACBC187S4FOR		300169	

CARBIDE INSERTS

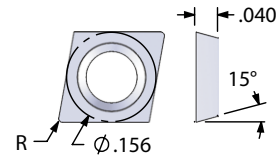

80° DIAMOND FLAT TOP

FIVE SCREWS	"R" CORNER RADIUS	ORDER #		EDP #	
		FIVE UNCOATED	FIVE ALTiN+	FIVE UNCOATED	FIVE ALTiN+
AT6+	0.003	ACD5031	ACD5031E	301001	301008
AT6+	0.007	ACD5071	ACD5071E	301015	301029
AT6+	0.015	ACD5151	ACD5151E	301057	301071

INDEXABLE BORING BAR ACCESSORIES

REPLACEMENT FLAG KEYS AND SCREWS

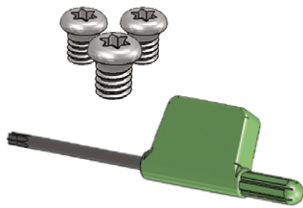

- All 3/16", 1/4", and 5/16" right and left-hand bars use AT6+ screws (for triangle or diamond-shaped inserts)
- All 3/8" and 1/2" bars use AT8+ screws
- AT6+ screws use AT6+ flag keys. AT8+ screws use AT8+ flag keys.

REPLACEMENT PACKS

ACCESSORY	SIZE	ORDER #	EDP #
FLAG KEY (2 PACK)	AT6+	A6KEY	302301
FLAG KEY (2 PACK)	AT8+	A8KEY	302304
SCREWS (10 PACK)	AT6+	A6SCREWS	302307
SCREWS (10 PACK)	AT8+	A8SCREWS	302310

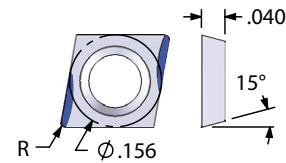

80° DIAMOND CHIP CONTROL
RIGHT HAND ONLY

FIVE SCREWS	"R" CORNER RADIUS	ORDER #		EDP #	
		FIVE UNCOATED	FIVE ALTiN+	FIVE UNCOATED	FIVE ALTiN+
AT6+	0.007	ACD507L3	ACD507L3E	301044	301051
AT6+	0.015	ACD515L3	ACD515L3E	301086	301093

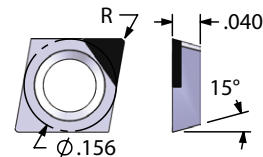

80° DIAMOND CBN/PCD TIPPED

ONE SCREW	"R" CORNER RADIUS	ORDER #		EDP #	
		ONE CBN	ONE PCD	ONE CBN	ONE PCD
AT6+	0.007	ACD5071CBN2	ACD5071PCD	301022	301036
AT6+	0.015	ACD5151CBN2	ACD5151PCD	301064	301078

Inserts and compatible bars are listed together.

[Go to Indexable Boring Overview](#)

INDEXABLE STEP BORING BAR AND INSERTS

1/2" SHANK STEP BARS WITH TRIANGLE SHAPED INSERTS

EACH BAR COMES WITH ONE SCREW AND ONE KEY. INSERTS SOLD SEPARATELY.

STEP BORING BAR

0.300 MINIMUM BORE

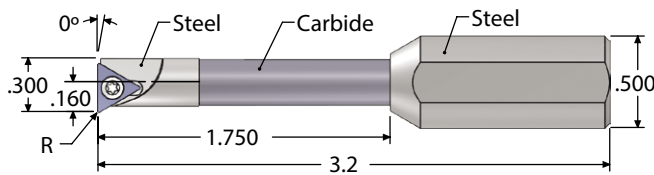

BAR FLAT	INSERT TYPE	RH/LH	ORDER #		EDP #	
			NO COOLANT HOLE	NO COOLANT HOLE	NO COOLANT HOLE	NO COOLANT HOLE
FLAT	ATD5	RIGHT	ACBT250S4FOR		300172	

CARBIDE INSERTS

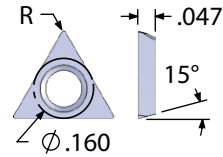

60° TRIANGLE FLAT TOP

FIVE SCREWS	"R" CORNER RADIUS	ORDER #		EDP #	
		FIVE UNCOATED	FIVE ALTiN+	FIVE UNCOATED	FIVE ALTiN+
AT6+	0.003	ATD5031	ATD5031E	301099	301106
AT6+	0.007	ATD5071	ATD5071E	301113	301127
AT6+	0.015	ATD5151	ATD5151E	301155	301169

STEP BORING BAR

0.300 MINIMUM BORE

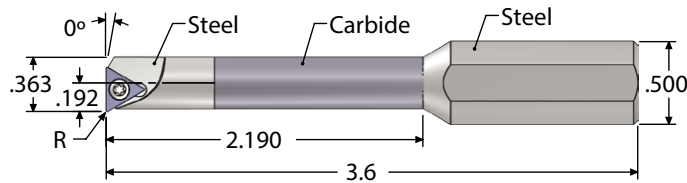

BAR FLAT	INSERT TYPE	RH/LH	ORDER #		EDP #	
			NO COOLANT HOLE	NO COOLANT HOLE	NO COOLANT HOLE	NO COOLANT HOLE
FLAT	ATD5	RIGHT	ACBT312S4FOR		300175	

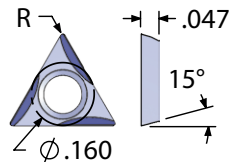

60° TRIANGLE CHIP CONTROL
RIGHT HAND ONLY

FIVE SCREWS	"R" CORNER RADIUS	ORDER #		EDP #	
		FIVE UNCOATED	FIVE ALTiN+	FIVE UNCOATED	FIVE ALTiN+
AT6+	0.007	ATD507L3	ATD507L3E	301142	301149
AT6+	0.015	ATD515L3	ATD515L3E	301184	301191

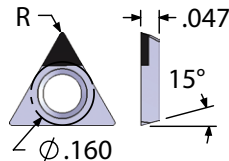

60° TRIANGLE CBN/PCD TIPPED

ONE SCREW	"R" CORNER RADIUS	ORDER #		EDP #	
		ONE CBN	ONE PCD	ONE CBN	ONE PCD
AT6+	0.007	ATD5071CBN2	ATD5071PCD	301120	301134
AT6+	0.015	ATD5151CBN2	ATD5151PCD	301162	301176

Inserts and compatible bars are listed together.

[Go to Indexable Boring Overview](#)

INDEXABLE BORING BAR FEED AND SPEED CHART

MATERIAL	HB/Rc	SPEED RANGE (SFM)		CUTTING CONDITIONS		
		UNCOATED	ALTIN+	MAX DOC ACD & ATD	MAX DOC ATP & ACP	FEED IPR
CAST IRON	160 HB	75-200	200-550	0.020	0.060	.0005-.010
CARBON STEEL	18 Rc	75-200	200-450	0.018	0.060	.0005-.010
ALLOY STEEL	20 Rc	75-200	200-425	0.015	0.060	.0005-.010
TOOL STEEL	25 Rc	75-175	175-300	0.010	0.030	.0005-.010
300 STAINLESS STEEL	150 HB	75-175	175-350	0.015	0.028	.0005-.010
400 STAINLESS STEEL	195 HB	75-210	130-420	0.012	0.028	.0005-.010
HIGH TEMP ALLOY (Ni & Co BASE)	20 Rc	50-130	130-300	0.008	0.020	.0005-.010
TITANIUM	25 Rc	50-120	120-275	0.009	0.022	.0005-.010
HEAT TREATED ALLOYS (38-45Rc)	40 Rc	50-100	100-200	0.005	0.010	.0005-.005
ALUMINUM	100 HB	75-250	250-750	0.025	0.095	.0005-.010
BRASS, ZINC	80 HB	75-300	250-650	0.023	0.090	.0005-.010

SFM = Surface Feet per Minute

Starting parameters only. Length to diameter ratios, setup, and machine rigidity may affect performance. The max Depth Of Cut (DOC) acceptable at the minimum Inches Per Revolution (IPR).

SELECTING AN INDEXABLE BORING BAR

1	From the part or print, verify the diameter of hole to be machined. Select the boring bar that has a minimum bore diameter smaller than the diameter to be machined.
2	Check machine for shank size needed. If the shank needs to be larger, consider a step bar.
3	Match the operation needed on the part with the necessary lead angle. Select 0° lead to bore to a shoulder. Select 5° lead to bore and face a shoulder.
4	Choose from flat top or chip control insert based on application and material being machined.
5	Choose from .003", .007", or .015" radius based on finish required and part specifications for corner radius.

SELECTING AN INDEXABLE INSERT GRADE

UNCOATED	is a submicron premium carbide grade for machining steel and non-ferrous materials.
ALTIN+	is a premium coated grade for steel, cast irons and high temperature alloys at highest SFM.
CBN	are ideal for hardened steel (45+ RC) and cast iron.
PCD	are ideal for non-ferrous materials.

INDEXABLE BORING BAR TROUBLESHOOTING

PROBLEM	CAUSE	SOLUTION
RAPID FLANK WEAR	CUTTING CONDITIONS	Reduce the cutting speed.
	INSERT	Select a coated grade.
	HEAT	Use the SCT coolant holder. If coolant is not available, use shop air and a coated tool. Use a coolant through boring bar.
BUILT-UP EDGE	INSERT	Select a coated grade.
	CUTTING FORCE	Use chip control insert to free up cut.
	HEAT	Use coolant through boring bar or holder. If coolant is not available, use shop air and a coated tool. Use coolant through boring bar.
INSERT BREAKAGE	CUTTING CONDITIONS	Reduce depth of cut. Reduce feed rate.
	INSERT	Select a larger corner radius
	PART	Check the drilled hole to make sure the full diameter of the drill is deeper than the programmed bore depth.
SURFACE TOO ROUGH	CUTTING CONDITIONS	Reduce feed rate. The rate is too great for the nose radius.
	INSERT	Select a larger corner radius. The feed rate (IPR) should not be greater than 1/2 the nose radius.
CHATTER	SETUP	Set insert above center. Change the speed of the machine. The overhang ratio should be less than 8x bar diameter for carbide. Clamping length should be at least 3x the boring bar diameter.
	BORING BAR	Select the largest diameter bar that will bore the required diameter.
TAPER BIGGER IN BACK	CUTTING FORCES	Forces may deflect bar below center causing the hole to become larger.
	BUILT-UP EDGE	A built-up edge will cause the hole to become large until the built-up edge breaks off, then hole will be smaller.
	PROGRAM	If the taper is consistent (not from chip packing) then the program can be altered to bore a taper in opposite direction resulting in a straight hole.
TAPER SMALLER IN BACK	CHIP PACKING	If the boring bar is too large to allow chips to evacuate then the chips may pack on the insert and cause the bar to deflect away from the bore.
	PROGRAM	If the taper is consistent (not from chip packing) then the program can be altered to bore a taper in opposite direction resulting in a straight hole.

CBN & PCD INSERTS TECHNICAL INFORMATION

PCD TIPPED INSERT FEED AND SPEED

MATERIAL	BHN/Rc	SPEED RANGE (SFM)	FEED IPR	PCD TIPPED INSERTS	
				TOOL DIA. .220-.363	TOOL DIA. .421-.560
				MAX DOC	MAX DOC
LOW SILICON ALUMINUM	225-350 BHN	1000-5000	.001-.007	0.025	0.08
HIGH SILICON ALUMINUM	270-425 BHN	600-3000	.001-.007	0.025	0.08
METAL MATRIX COMPOSITIES	N/A	500-2000	.001-.007	0.015	0.035
COPPER ALLOYS, BRASS, BRONZE	80-120 BHN	750-3500	.001-.007	0.025	0.08
PRESINTERED TUNGSTEN CARBIDE	140-300 BHN	100-350	.001-.005	0.007	0.012
ACRYLICS	N/A	700-1500	.001-.007	0.025	0.08
FIBERGLASS	N/A	600-1000	.001-.007	0.02	0.06
GRAPHITES	N/A	600-1000	.001-.007	0.025	0.08
NYLON, PLASTIC	N/A	700-1500	.001-.007	0.025	0.08
HARD RUBBER	N/A	500-2500	.001-.007	0.025	0.08

APPLICATION GUIDELINES
Make sure the machine and setup is rigid and solid. Chatter will cause chipping.
Tool height when boring should be slightly above center. Tool deflection will put the tool on center.
Do not stop the machine with the tool in cut. This will result in tool breakage.
Use of coolant will reduce heat and improve surface finish.
Do not contact the tool to a hard surface prior to the machining process- this will cause chipping.
Higher speeds minimize tool buildup.
Depth of cut should not exceed 70% of PCD tip length.

SFM = Surface Feet per Minute DOC= Depth of Cut

AS THE DOC DECREASES THE FEED RATE CAN INCREASE

SCT PCD tools and inserts are excellent for continuous cutting of a wide range of non-ferrous and non-metal materials. The products are precision ground for machining to sub-micron finishes with maximum tool life. PCD allows for higher cutting speeds with longer tool life.

CBN TIPPED INSERT FEED AND SPEED

MATERIAL	BHN/Rc	SPEED RANGE (SFM)	FEED IPR	CBN TIPPED INSERTS	
				TOOL DIA. .220-.363	TOOL DIA. .421-.560
				MAX DOC	MAX DOC
HEAT TREATED ALLOY	45-60Rc	200-600	.001-.005	0.01	0.04
TOOL STEEL	45-60Rc	200-600	.001-.005	0.01	0.04
NODULAR IRON	N/A	600-1500	.001-.005	0.009	0.035
PEARLITIC IRON	220-240 BHN	600-2500	.001-.007	0.009	0.035
WHITE/CHILLED IRON	54-60Rc	200-500	.001-.005	0.008	0.035
SUPER ALLOY Ni BASE	240-475 BHN	200-800	.001-.005	0.008	0.035
COBALT BASED ALLOY, STELLITE	45-55Rc	200-500	.001-.005	0.008	0.035
INCONELS	45-55Rc	200-500	.001-.005	0.008	0.035

APPLICATION GUIDELINES
Make sure the machine and setup is rigid and solid. Chatter will cause chipping
Tool height when boring should be slightly above center. Tool deflection will put the tool on center.
Do not stop the machine with the tool in cut. This will result in tool breakage.
Coolant use is not advised as it could cause thermal cracking.
Do not contact the tool to a hard surface prior to the machining process. This will cause chipping.
Depth of cut should not exceed 30% of CBN tip length.

SFM = Surface Feet per Minute DOC= Depth of Cut

AS THE DOC DECREASES THE FEED RATE CAN INCREASE

SCT CBN tools and inserts are excellent for continuous cutting of a wide range of hardened steels, powdered metals, cast irons and super alloys. The products are precision ground with hones for machining to sub-micron finishes with maximum tool life.

CBN tipped tools and inserts can take the place of grinding.

PORT TOOL PRODUCT OVERVIEW

All Port Tools are ground between centers to ensure absolute concentricity. They are made from heat-treated alloy steel with brazed carbide inserts. They are designed to enlarge a pre-drilled hole and easily produce a complex form. Port Tools can be used for both lathe and mill applications. Technical information available on page 108. **Modified Port Tools and Specials** quoted upon request.

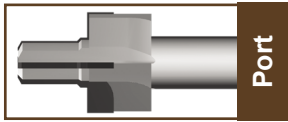

MS33651 (p.91)
This carbide tipped port tool also meets the requirements of the AND10071 port.

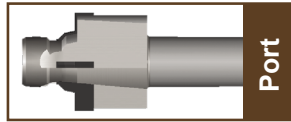

MS16142-S (p.91)
This port is also called the O-Ring Boss or ORB, SAEJ1926-1, SAEJ514 or just SAE (dash number). The solid pilot design does not cut the minor-thread diameter.

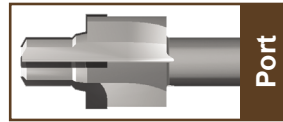

MS16142-R (p.92-93)
This port is also called the O-Ring Boss or ORB, SAEJ1926-1, SAEJ514 or just SAE (dash number). The reamer pilot design cuts the minor-thread diameter.

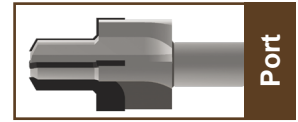

BSPP- Pipe Reamer (p.94)
British standard parallel pipe port tools (PT-BSPP) cut the minor-thread diameter, the 45° angle, and the spot face.

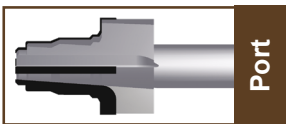

BACD2036 (p.94)
BACD2036 carbide tipped port tools are designed to cut this otherwise difficult-to-cut port.

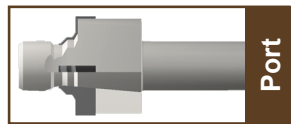

MS33649-S (p.95)
This port is also called the AS5202. The solid pilot design does not cut the minor-thread diameter.

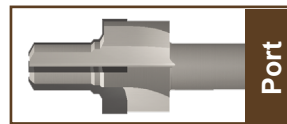

MS33649-R (p.96-97)
This port is also called the AS5202. The reamer pilot design cuts the minor-thread diameter.

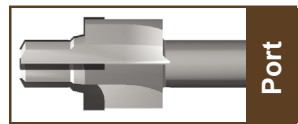

ISO 6149/1 (p.98)
This is also called the SAEJ2244-1. This port does not have the identification notch that identifies it as a metric port.

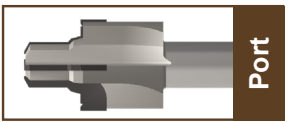

ISO 6149/1 (ID) (p.99)
This port is also called the SAEJ2244-1. This port has the identification notch that identifies it as a metric port.

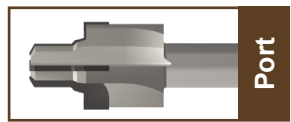

ISO 6149/1 (SF) (p.100)
This port is also called the SAEJ2244-1. This port has a larger spot face without the identification notch.



AND10050-S (p.101)
The solid pilot design does not cut the minor-thread diameter.

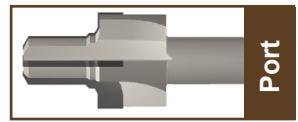

AND10050-R (p.102)
The reamer pilot design cuts the minor-thread diameter.

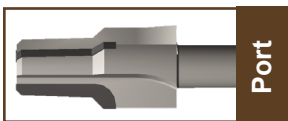

Tapered Pipe Reamer (p.103)
The (PRSS) tapered pipe reamers cut taper minor diameter of the NPT (1°47' angle) and the 45° countersink for the thread.

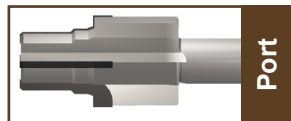

RPT/RFPT (p.104-105)
RPT/RFPT port tool will cut a Rosan cavity per AS1300 specification. Another name for this port is PS10035.

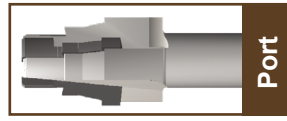

MS33514 (p.106)
This port will cut the AS33514, MS33514 and MS33515 in both style "E" and "G" configurations.

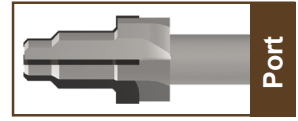

MS21921 (p.107)
MS21921 port tools are made with the same quality heat-treated steel and carbide as the rest of our port tools.

New Product
2021



ISO 1179
1179 port tools cut the minor thread (BSPP) diameter, 90 degree included angle, and the spot face per the requirements of ISO 1179.

New Product
2021

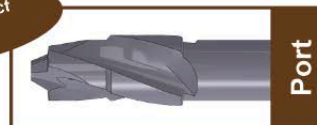

Autoclave (Med. Pressure)
Completes the port profile per the Parker Autoclave standard. These medium-pressure tools cut the opening chamfer, minor thread diameter, and the port seat.

PORT AND CAVITY TOOL TECHNICAL INFORMATION PAGE 108

MS33651 (AND10071) - PORT TOOL - CARBIDE TIPPED

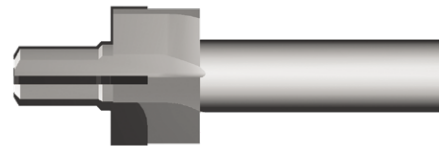
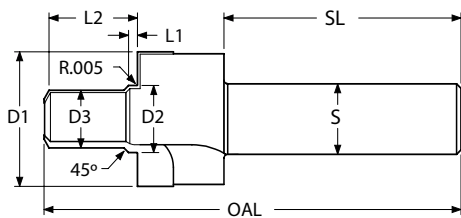

- Polished flute face for optimum performance
- ALTiN+ coating for improved surface finish

D1	D2	D3	L1	L2	S	SL	OAL	FLUTES	THREAD	ORDER #		EDP #	
										UNCOATED	ALTiN+	UNCOATED	ALTiN+
1.050	0.523	0.450	0.070	0.690	0.500	1.88	3.25	4	0.500-20 UNF-3B	MS33651	MS33651A	401001	401010

Thread mills are available. See pages 8-18

MS16142 (SAEJ1926/1) (SAEJ514) O-RING BOSS SOLID PILOT - CARBIDE TIPPED

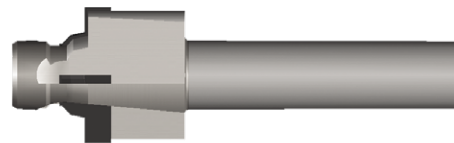
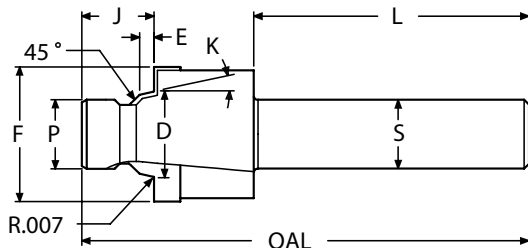

- Ideal for non-standard minor diameter lengths
- Often called ORB (followed by port size number)
- Meets the requirements of SAEJ1926/1
- Polished flute face for optimum performance
- ALTiN+ coating for improved surface finish
- Meets the requirements of SAEJ514

Click here to be directed to the new product pages.

SAE J1926 Replaces MS16142 Port Tools



SOLID PILOT

SAE J1926-S Replaces MS16142-S

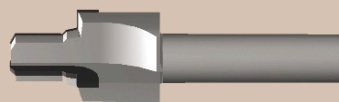

REAMER PILOT

SAE J1926-R Replaces MS16142-R

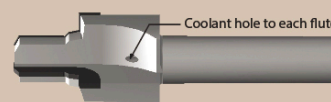

COOLANT THROUGH

SAE J1926-X Replaces MS16142-X

MS16142 (SAEJ1926/1) (SAEJ514) O-RING BOSS REAMER PILOT - CARBIDE TIPPED

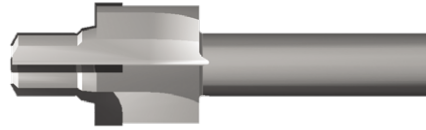
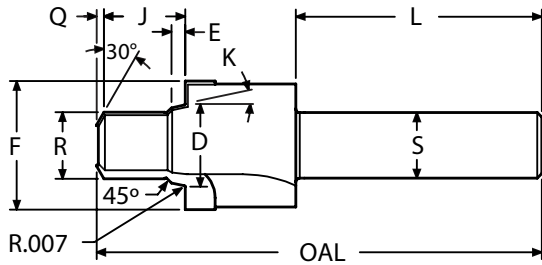

- Reams minor thread diameter to size
- Often called ORB (followed by port size number)
- Meets the requirements of SAEJ1926/1
- Precision ground for maximum concentricity
- ALTiN+ coating extends tool life
- Meets the requirements of SAEJ514

**Click here to be directed to the
new product pages.**

SAE J1926 Replaces MS16142 Port Tools

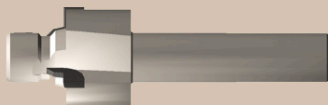

SOLID PILOT

SAE J1926-S Replaces MS16142-S



REAMER PILOT

SAE J1926-R Replaces MS16142-R

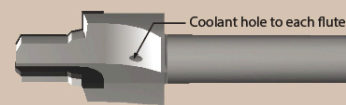

COOLANT THROUGH

SAE J1926-X Replaces MS16142-X

[Go to Port Tool Overview](#)

MS16142 (SAEJ1926/1) (SAEJ514) O-RING BOSS REAMER PILOT - CARBIDE TIPPED - COOLANT THROUGH

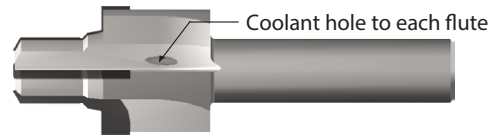
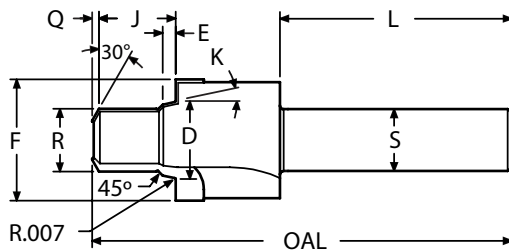

- Reams minor thread diameter to size
- Precision ground for maximum concentricity
- Often called ORB (followed by port size number)
- ALTiN+ coating extends tool life
- Meets the requirements of SAEJ1926/1
- Meets the requirements of SAEJ514

**Click here to be directed to the
new product pages.**

SAE J1926 Replaces MS16142 Port Tools

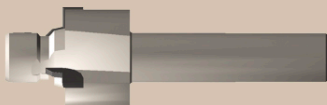

SOLID PILOT

SAE J1926-S Replaces MS16142-S

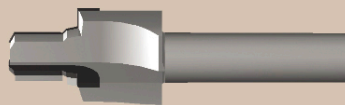

REAMER PILOT

SAE J1926-R Replaces MS16142-R

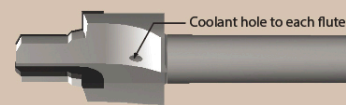

COOLANT THROUGH

SAE J1926-X Replaces MS16142-X

THREAD MILLS

SINGLE POINT

INDEXABLE TOOLS

Port Tools

SPECIALTY

[Go to Port Tool Overview](#)

BRITISH STANDARD PARALLEL PIPE - PORT TOOL CARBIDE TIPPED

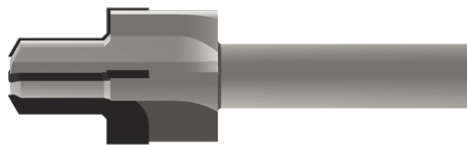
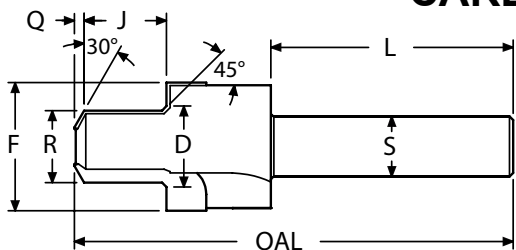

- Meets the requirements of the ISO/BS2779
- Precision ground for maximum concentricity
- Polished flute face for optimum performance
- Bodies made with head treated alloy steel

D	F	J	R	Q	L	S	OAL	FLUTES	THREAD	ORDER #		EDP #	
										UNCOATED	ALTIN+	UNCOATED	ALTIN+
0.398	0.719	0.565	0.345	0.045	2.00	0.500	3.62	3	1/8 BSPP	PT-BSPP-1/8	PT-BSPP-1/8A	402816	402866
0.533	0.938	0.683	0.459	0.065	2.00	0.500	3.62	3	1/4 BSPP	PT-BSPP-1/4	PT-BSPP-1/4A	402813	402863
0.671	1.063	0.683	0.597	0.080	2.00	0.500	3.62	4	3/8 BSPP	PT-BSPP-3/8	PT-BSPP-3/8A	402822	402872
0.840	1.250	0.801	0.741	0.090	2.00	0.750	3.62	4	1/2 BSPP	PT-BSPP-1/2	PT-BSPP-1/2A	402810	402860
1.055	1.500	0.880	0.958	0.120	2.50	0.750	4.37	4	3/4 BSPP	PT-BSPP-3/4	PT-BSPP-3/4A	402819	402869
1.325	1.875	0.998	1.201	0.120	2.50	1.000	4.62	4	1.0 BSPP	PT-BSPP-1.0	PT-BSPP-1.0A	402807	402857
1.665	2.313	1.078	1.541	0.125	2.50	1.000	4.62	4	1 1/4 BSPP	PT-BSPP-1-1/4	PT-BSPP-1-1/4A	402804	402854
1.897	2.563	1.078	1.774	0.125	2.50	1.000	4.88	4	1 1/2 BSPP	PT-BSPP-1-1/2	PT-BSPP-1-1/2A	402801	402851

Thread mills are available. See page 22.

BACD2036 - PORT TOOL - CARBIDE TIPPED

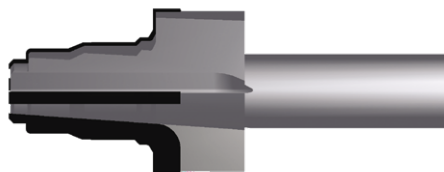
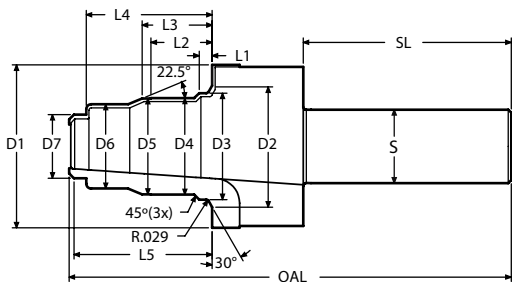

D1	D2	D3	D4	D5	D6	D7	L1	L2	L3	L4	L5	S	SL	OAL	FLUTES	THREAD	ORDER #		EDP #	
																	UNCOATED	ALTIN+	UNCOATED	ALTIN+
0.888	0.570	0.4565	0.392	0.387	0.2945	.170	.083	.425	.480	0.971	1.071	1/2	2.00	4.00	3	0.4375-20 UNJF-3B	Solid Carbide			
																	BACD2036-4	BACD2036-4A	403413	403443
1.012	0.696	0.5825	0.512	0.507	0.4195	.280	.091	.450	.505	1.004	1.104	1/2	2.00	4.00	3	0.5625-18 UNJF-3B	Carbide Tipped			
																	BACD2036-6	BACD2036-6A	403416	403446
1.290	0.883	0.7715	0.693	0.688	0.6110	.400	.104	.545	.605	1.144	1.244	3/4	2.13	4.25	4	0.7500-18 UNJF-3B	BACD2036-8	BACD2036-8A	403419	403449
1.415	1.008	0.8985	0.810	0.804	0.7330	.490	.115	.600	.665	1.215	1.340	3/4	2.13	4.50	4	0.8750-14 UNJF-3B	BACD2036-10	BACD2036-10A	403401	403431
1.665	1.242	1.0885	0.985	0.980	0.8610	.650	.133	.625	.715	1.287	1.412	3/4	2.13	4.50	4	1.0625-12 UNJF-3B	BACD2036-12	BACD2036-12A	403404	403434
1.965	1.495	1.3385	1.235	1.230	1.1140	.825	.133	.665	.755	1.392	1.517	1	2.13	4.50	4	1.3125-16 UNJF-3B	BACD2036-16	BACD2036-16A	403407	403437
2.310	1.808	1.6502	1.549	1.542	1.4260	1.130	0.133	0.650	0.755	1.396	1.616	1	2.25	5.00	4	1.6250-12 UNJF-3B	BACD2036-20	BACD2036-20A	403410	403440

Thread mills are available. See pages 8-18.

[Go to Port Tool Overview](#)

MS33649 (AS5202) - SOLID PILOT PORT TOOL CARBIDE TIPPED

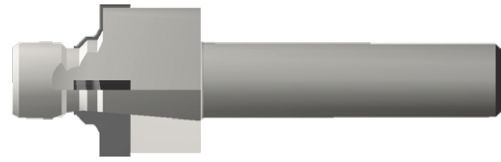
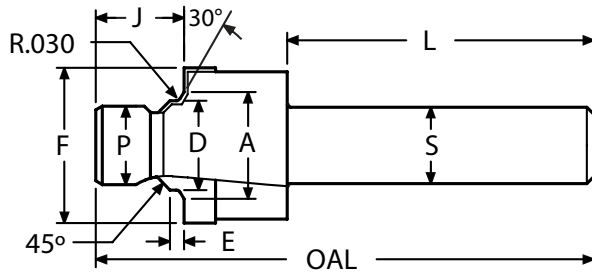

- Ideal for non-standard minor diameter lengths
- Polished flute face for optimum performance
- ALTiN+ coating for improved surface finish
- This port requires a UNJ thread which will specify a larger minor thread diameter

A	D	E	F	J	P	L	S	OAL	FLUTES	TUBE	THREAD	ORDER #		EDP #	
												UNCOATED	ALTiN+	UNCOATED	ALTiN+
0.367	0.2665	0.071	0.575	0.345	0.217	2.00	0.500	3.00	3	N/A	0.2500-28	MS33649-1S	MS33649-1SA	401616	401686

AS5202 Replaces MS33649 Port Tools

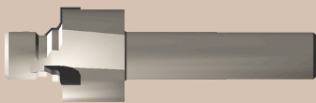

SOLID PILOT

AS5202-S Replaces MS33649-S



REAMER PILOT

AS5202-R Replaces MS33649-R

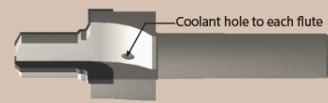

COOLANT THROUGH

AS5202-X Replaces MS33649-X

**Click here to be directed to the
new product pages.**

2.433	2.2733	0.133	3.030	0.800	2.172	2.25	1.250	4.50	4	1.750	UNJ-3B	MS33649-20S	MS33649-20SA	401620	401690
2.683	2.5265	0.133	3.520	0.800	2.422	2.50	1.250	4.60	4	2.000	2.5000-12 UNJ-3B	MS33649-32S	MS33649-32SA	401631	401701

Thread mills are available. See pages 8-18.

[Go to Port Tool Overview](#)

MS33649 (AS5202) - REAMER PILOT PORT TOOL CARBIDE TIPPED

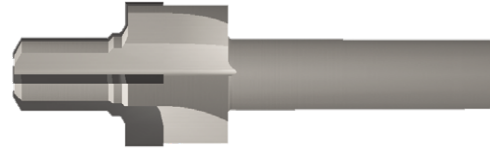
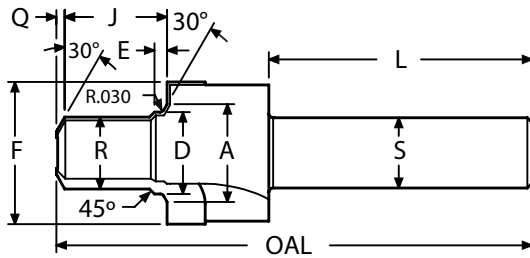

- Reams minor thread diameter to size
- Precision ground for maximum concentricity
- ALTiN+ coated tool for higher cutting speed
- This port requires a UNJ thread which specifies a larger minor-thread diameter

A	D	E	F	J	Q	R	L	S	OAL	FLUTES	TUBE	THREAD	ORDER #		EDP #	
													UNCOATED	ALTiN+	UNCOATED	ALTiN+
0.367	0.2665	0.071	0.575	0.425	0.025	0.219	2.00	0.500	3.00	3	N/A	0.2500-28 UNJ-3B	Solid Carbide			
													MS33649-1R	MS33649-1RA	401778	401878

AS5202 Replaces MS33649 Port Tools



SOLID PILOT

AS5202-S Replaces MS33649-S



REAMER PILOT

AS5202-R Replaces MS33649-R

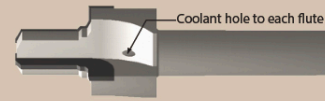

COOLANT THROUGH

AS5202-X Replaces MS33649-X

Click here to be directed to the new product pages.

2.433	2.2755	0.133	3.050	1.263	0.095	2.174	2.50	1.250	4.92	4	1.750	UNJ-3B	MS33649-28R	MS33649-28RA	401790	401890
2.683	2.5265	0.133	3.520	1.388	0.095	2.424	2.50	1.250	5.15	4	2.000	2.2500-12 UNJ-3B	MS33649-32R	MS33649-32RA	401799	401899

Thread mills are available. See pages 8-18.

[Go to Port Tool Overview](#)

MS33649 (AS5202) - REAMER PILOT PORT TOOL COOLANT THROUGH - CARBIDE TIPPED

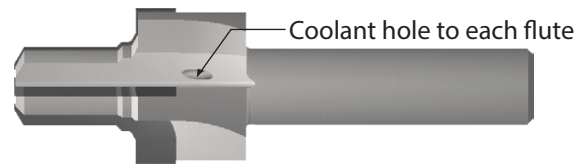
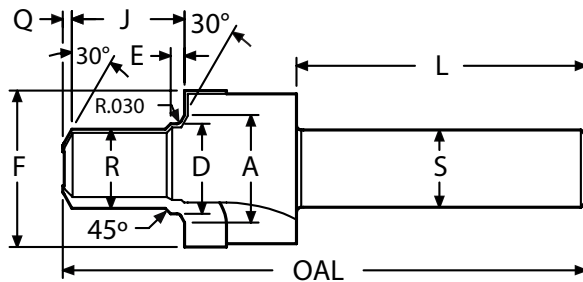

- Reams minor thread diameter to size
- Precision ground for maximum concentricity
- ALTiN+ coated tool for higher cutting speed
- This port requires a UNJ thread which specifies a larger minor thread diameter

AS5202 Replaces MS33649 Port Tools

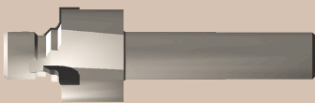

SOLID PILOT

AS5202-S Replaces MS33649-S



REAMER PILOT

AS5202-R Replaces MS33649-R

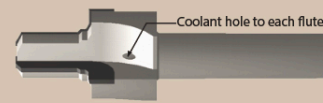

COOLANT THROUGH

AS5202-X Replaces MS33649-X

**Click here to be directed to the
new product pages.**

[Go to Port Tool Overview](#)

ISO 6149/1 (SAEJ2244/1) METRIC PORT TOOL CARBIDE TIPPED

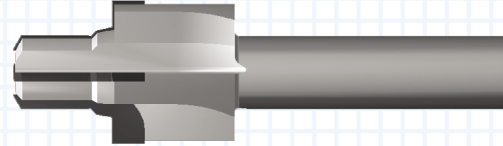
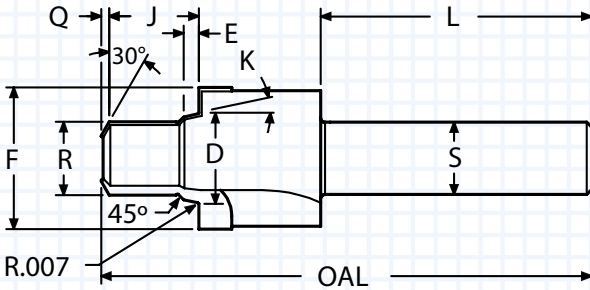

- Bodies are made with heat treated alloy steel
- Carbide inserts are made with premium submicron carbide
- Polished flute face for optimum performance
- ALTiN+ coated for improved surface finish

K (deg)	D (mm)	E (mm)	F (mm)	R (mm)	J (mm)	Q (inch)	L (inch)	S (inch)	OAL (inch)	FLUTES	THREAD	ORDER #		EDP #	
												UNCOATED	ALTiN+	UNCOATED	ALTiN+
12°	9.15	1.8	14.1	7.0	11.6	0.032	1.75	0.500	3.00	3	M8X1	6149-M8X1	6149-M8X1A	402137	402187
12°	11.15	1.8	16.1	9.0	11.6	0.045	1.75	0.500	3.00	3	M10X1	6149-M10X1	6149-M10X1A	402101	402151
15°	13.85	2.6	19.1	10.5	14.1	0.045	1.88	0.500	3.12	3	M12X1.5	6149-M12X1.5	6149-M12X1.5A	402104	402154
15°	15.85	2.6	21.1	12.5	14.1	0.055	1.88	0.500	3.38	4	M14X1.5	6149-M14X1.5	6149-M14X1.5A	402107	402157
15°	17.85	2.6	24.1	14.5	15.6	0.060	1.88	0.500	3.38	4	M16X1.5	6149-M16X1.5	6149-M16X1.5A	402110	402160
15°	19.85	2.6	26.1	16.5	17.1	0.070	2.12	0.750	3.70	4	M18X1.5	6149-M18X1.5	6149-M18X1.5A	402113	402163
15°	21.85	2.6	27.1	18.5	17.5	0.080	2.12	0.750	3.75	4	M20X1.5	6149-M20X1.5	6149-M20X1.5A	402116	402166
15°	23.85	2.6	29.1	20.5	18.1	0.080	2.12	0.750	3.80	4	M22X1.5	6149-M22X1.5	6149-M22X1.5A	402119	402169
15°	29.45	3.3	34.2	25.0	22.1	0.080	2.12	0.750	3.94	4	M27X2.0	6149-M27X2.0	6149-M27X2.0A	402122	402172
15°	35.45	3.3	43.1	31.0	22.1	0.090	2.25	1.000	4.25	4	M33X2.0	6149-M33X2.0	6149-M33X2.0A	402125	402175
15°	44.45	3.3	52.1	40.0	22.6	0.090	2.25	1.000	4.35	4	M42X2.0	6149-M42X2.0	6149-M42X2.0A	402128	402178
15°	50.45	3.3	57.1	46.0	25.1	0.095	2.25	1.000	4.35	4	M48X2.0	6149-M48X2.0	6149-M48X2.0A	402131	402181
15°	62.45	3.3	67.1	58.0	27.6	0.095	2.25	1.250	4.35	4	M60X2.0	6149-M60X2.0	6149-M60X2.0A	402134	402184

Thread mills are available. See pages 24-28.

[Go to Port Tool Overview](#)

ISO 6149/1 (SAEJ2244/1) METRIC PORT TOOL WITH ID NOTCH - CARBIDE TIPPED

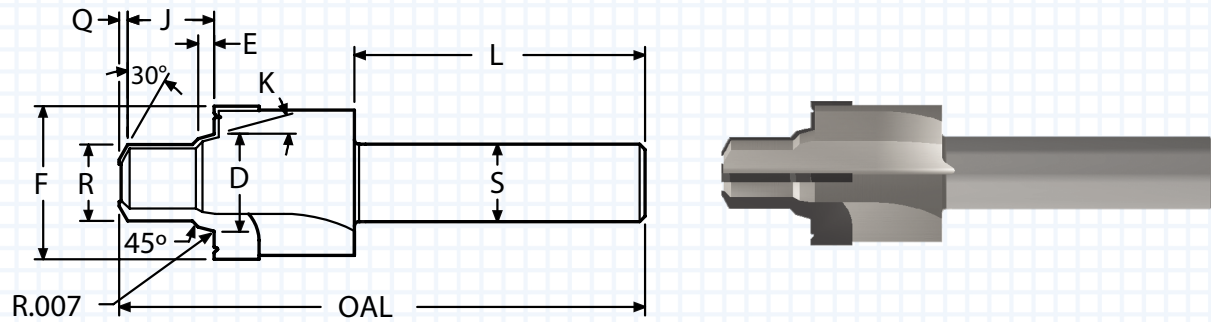

- Metric port with identification notch
- Polished flute face for optimum performance
- Precision ground for maximum concentricity
- ALTiN+ coating extends tool life

K (deg)	D (mm)	E (mm)	F (mm)	R (mm)	J (mm)	Q (inch)	L (inch)	S (inch)	OAL (inch)	FLUTES	THREAD	ORDER #		EDP #	
												UNCOATED	ALTiN+	UNCOATED	ALTiN+
12°	9.15	1.8	17.1	7.0	11.6	0.032	1.75	0.500	3.00	3	M8X1	6149-M8X1-ID	6149-M8X1-IDA	402337	402387
12°	11.15	1.8	20.1	9.0	11.6	0.045	1.75	0.500	3.00	3	M10X1	6149-M10X1-ID	6149-M10X1-IDA	402301	402351
15°	13.85	2.6	23.1	10.5	14.1	0.045	1.88	0.500	3.12	3	M12X1.5	6149-M12X1.5-ID	6149-M12X1.5-IDA	402304	402354
15°	15.85	2.6	25.1	12.5	14.1	0.055	1.88	0.500	3.38	4	M14X1.5	6149-M14X1.5-ID	6149-M14X1.5-IDA	402307	402357
15°	17.85	2.6	28.1	14.5	15.6	0.060	1.88	0.500	3.38	4	M16X1.5	6149-M16X1.5-ID	6149-M16X1.5-IDA	402310	402360
15°	19.85	2.6	30.1	16.5	17.1	0.070	2.12	0.750	3.70	4	M18X1.5	6149-M18X1.5-ID	6149-M18X1.5-IDA	402313	402363
15°	21.85	2.6	32.1	18.5	17.5	0.080	2.12	0.750	3.75	4	M20X1.5	6149-M20X1.5-ID	6149-M20X1.5-IDA	402316	402366
15°	23.85	2.6	34.1	20.5	18.1	0.080	2.12	0.750	3.80	4	M22X1.5	6149-M22X1.5-ID	6149-M22X1.5-IDA	402319	402369
15°	29.45	3.3	40.1	25.0	22.1	0.080	2.12	0.750	3.94	4	M27X2.0	6149-M27X2.0-ID	6149-M27X2.0-IDA	402322	402372
15°	35.45	3.3	49.1	31.0	22.1	0.090	2.25	1.000	4.25	4	M33X2.0	6149-M33X2.0-ID	6149-M33X2.0-IDA	402325	402375
15°	44.45	3.3	60.1	40.0	22.6	0.090	2.25	1.000	4.35	4	M42X2.0	6149-M42X2.0-ID	6149-M42X2.0-IDA	402328	402378
15°	50.45	3.3	66.1	46.0	25.1	0.095	2.25	1.000	4.35	4	M48X2.0	6149-M48X2.0-ID	6149-M48X2.0-IDA	402331	402381
15°	62.45	3.3	76.1	58.0	27.6	0.095	2.25	1.250	4.35	4	M60X2.0	6149-M60X2.0-ID	6149-M60X2.0-IDA	402334	402384

Thread mills are available. See pages 24-28.

[Go to Port Tool Overview](#)

ISO 6149/1 (SAEJ2244/1) METRIC PORT TOOL WITH LARGE SPOTFACE - CARBIDE TIPPED

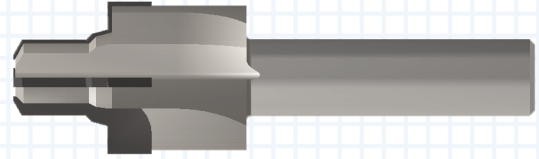
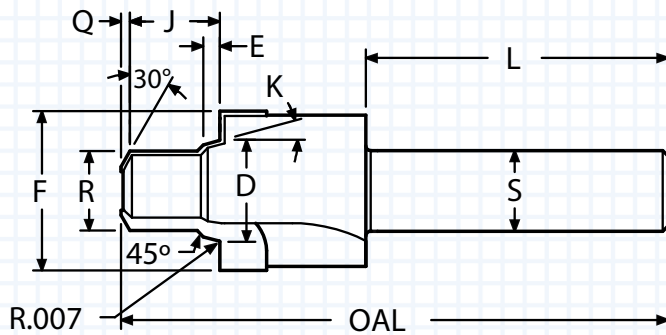

- Metric port without identification notch
- Polished flute face for optimum performance
- Precision ground for maximum concentricity
- ALTiN+ coating extends tool life

K (deg)	D (mm)	E (mm)	F (mm)	R (mm)	J (mm)	Q (inch)	L (inch)	S (inch)	OAL (inch)	FLUTES	THREAD	ORDER #		EDP #	
												UNCOATED	ALTiN+	UNCOATED	ALTiN+
12°	9.15	1.8	17.1	7.0	11.6	0.032	1.75	0.500	3.00	3	M8X1	6149-M8X1-F17	6149-M8X1-F17A	402228	402278
12°	11.15	1.8	20.1	9.0	11.6	0.045	1.75	0.500	3.00	3	M10X1	6149-M10X1-F20	6149-M10X1-F20A	402201	402251
15°	13.85	2.6	23.1	10.5	14.1	0.045	1.88	0.500	3.12	3	M12X1.5	6149-M12X1.5-F23	6149-M12X1.5-F23A	402204	402254
15°	15.85	2.6	25.1	12.5	14.1	0.055	1.88	0.500	3.38	4	M14X1.5	6149-M14X1.5-F25	6149-M14X1.5-F25A	402207	402257
15°	17.85	2.6	28.1	14.5	15.6	0.060	1.88	0.500	3.38	4	M16X1.5	6149-M16X1.5-F28	6149-M16X1.5-F28A	402210	402260
15°	19.85	2.6	30.1	16.5	17.1	0.070	2.12	0.750	3.70	4	M18X1.5	6149-M18X1.5-F30	6149-M18X1.5-F30A	402213	402263
15°	21.85	2.6	32.1	18.5	17.5	0.080	2.12	0.750	3.75	4	M20X1.5	6149-M20X1.5-F32	6149-M20X1.5-F32A	402216	402266
15°	23.85	2.6	34.1	20.5	18.1	0.080	2.12	0.750	3.80	4	M22X1.5	6149-M22X1.5-F34	6149-M22X1.5-F34A	402219	402269
15°	29.45	3.3	40.1	25.0	22.1	0.080	2.12	0.750	3.94	4	M27X2.0	6149-M27X2.0-F40	6149-M27X2.0-F40A	402222	402272
15°	35.45	3.3	49.1	31.0	22.1	0.090	2.25	1.000	4.25	4	M33X2.0	6149-M33X2.0-F49	6149-M33X2.0-F49A	402225	402275

Thread mills are available. See pages 24-28.

Larger sizes are available upon request. It will be quoted as a special order.

[Go to Port Tool Overview](#)

AND10050 - SOLID PILOT PORT TOOL CARBIDE TIPPED

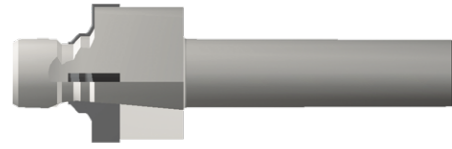
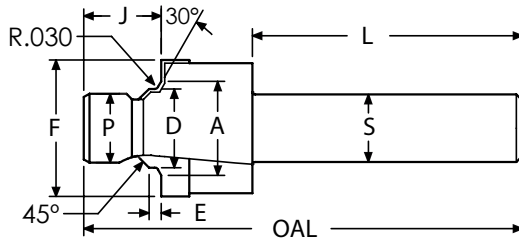

- Bodies made with heat treated alloy steel
- Ideal for non-standard minor thread diameter lengths
- ALTiN+ coating for improved surface finish
- Carbide inserts made with premium submicron carbide

A	D	E	F	J	P	L	S	OAL	FLUTES	TUBE	THREAD	ORDER #		EDP #	
												UNCOATED	ALTiN+	UNCOATED	ALTiN+
0.446	0.3305	0.071	0.742	0.365	0.270	2.00	0.500	3.00	3	0.125	0.3125-24 UNF-3B	AND10050-2S	AND10050-2SA	402419	402469
0.508	0.3925	0.071	0.805	0.415	0.331	2.00	0.500	3.00	3	0.188	0.3750-24 UNF-3B	AND10050-3S	AND10050-3SA	402425	402475
0.570	0.4565	0.083	0.888	0.445	0.385	2.00	0.500	3.12	4	0.250	0.4375-20 UNF-3B	AND10050-4S	AND10050-4SA	402428	402478
0.633	0.5195	0.083	0.950	0.465	0.448	2.00	0.500	3.12	4	0.312	0.5000-20 UNF-3B	AND10050-5S	AND10050-5SA	402431	402481
0.696	0.5825	0.091	1.012	0.495	0.504	2.00	0.500	3.25	4	0.375	0.5625-18 UNF-3B	AND10050-6S	AND10050-6SA	402434	402484
0.883	0.7715	0.102	1.240	0.560	0.685	2.12	0.750	3.57	4	0.500	0.7500-16 UNF-3B	AND10050-8S	AND10050-8SA	402437	402487
1.008	0.8985	0.115	1.415	0.590	0.801	2.12	0.750	3.66	4	0.625	0.8750-14 UNF-3B	AND10050-10S	AND10050-10SA	402401	402451
1.242	1.0885	0.133	1.665	0.640	0.975	2.12	0.750	3.75	4	0.750	1.0625-12 UN-3B	AND10050-12S	AND10050-12SA	402404	402454
1.495	1.3385	0.133	1.965	0.710	1.225	2.25	1.000	4.05	4	1.000	1.3125-12 UN-3B	AND10050-16S	AND10050-16SA	402407	402457
1.808	1.6505	0.133	2.310	0.750	1.537	2.25	1.000	4.20	4	1.250	1.6250-12 UN-3B	AND10050-20S	AND10050-20SA	402410	402460
2.058	1.9005	0.133	2.628	0.750	1.787	2.25	1.000	4.20	4	1.500	1.8750-12 UN-3B	AND10050-24S	AND10050-24SA	402413	402463
2.433	2.2755	0.133	3.050	0.800	2.162	2.50	1.250	4.50	4	1.750	2.2500-12 UN-3B	AND10050-28S	AND10050-28SA	402416	402466
2.683	2.5265	0.133	3.520	0.800	2.412	2.50	1.250	4.60	4	2.000	2.5000-12 UN-3B	AND10050-32S	AND10050-32SA	402422	402472

Thread mills are available. See pages 8-18.

[Go to Port Tool Overview](#)

AND10050 - REAMER PILOT PORT TOOL CARBIDE TIPPED

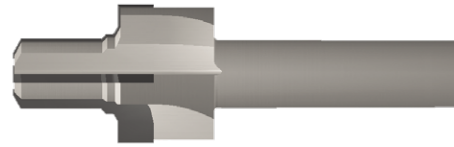
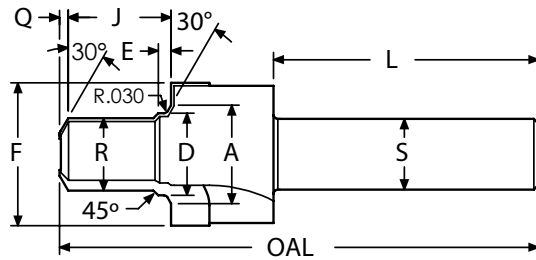

- Reams the minor thread diameter to size
- Bodies made with heat treated alloy steel
- Bodies made with head treated alloy steel
- ALTiN+ coating extends tool life

A	D	E	F	J	R	Q	L	S	OAL	FLUTES	TUBE	THREAD	ORDER #		EDP #	
													UNCOATED	ALTiN+	UNCOATED	ALTiN+
0.446	0.3305	0.071	0.742	0.520	0.271	0.032	1.75	0.500	3.00	3	0.125	0.3125-24 UNF-3B	AND10050-2R	AND10050-2RA	402528	402628
0.508	0.3925	0.071	0.805	0.520	0.333	0.040	1.75	0.500	3.00	3	0.188	0.3750-24 UNF-3B	AND10050-3R	AND10050-3RA	402537	402637
0.570	0.4565	0.083	0.888	0.610	0.386	0.045	1.88	0.500	3.12	4	0.250	0.4375-20 UNF-3B	AND10050-4R	AND10050-4RA	402543	402643
0.633	0.5195	0.083	0.950	0.610	0.449	0.045	1.88	0.500	3.12	4	0.312	0.5000-20 UNF-3B	AND10050-5R	AND10050-5RA	402549	402649
0.696	0.5825	0.091	1.012	0.630	0.506	0.060	1.88	0.500	3.38	4	0.375	0.5625-18 UNF-3B	AND10050-6R	AND10050-6RA	402555	402655
0.883	0.7715	0.102	1.240	0.738	0.686	0.070	2.12	0.750	3.70	4	0.500	0.7500-16 UNF-3B	AND10050-8R	AND10050-8RA	402561	402661
1.008	0.8985	0.115	1.415	0.801	0.802	0.080	2.12	0.750	3.80	4	0.625	0.8750-14 UNF-3B	AND10050-10R	AND10050-10RA	402501	402601
1.242	1.0885	0.133	1.665	0.926	0.976	0.080	2.12	0.750	3.94	4	0.750	1.0625-12 UN-3B	AND10050-12R	AND10050-12RA	402507	402607
1.495	1.3385	0.133	1.965	0.958	1.226	0.080	2.25	1.000	4.25	4	1.000	1.3125-12 UN-3B	AND10050-16R	AND10050-16RA	402513	402613
1.808	1.6505	0.133	2.310	1.004	1.538	0.090	2.25	1.000	4.35	4	1.250	1.6250-12 UN-3B	AND10050-20R	AND10050-20RA	402519	402619
2.058	1.9005	0.133	2.628	1.145	1.788	0.095	2.25	1.000	4.54	4	1.500	1.8750-12 UN-3B	AND10050-24R	AND10050-24RA	402522	402622
2.433	2.2755	0.133	3.050	1.260	2.163	0.095	2.50	1.250	4.92	4	1.750	2.2500-12 UN-3B	AND10050-28R	AND10050-28RA	402525	402625
2.683	2.5265	0.133	3.520	1.395	2.413	0.095	2.50	1.250	5.15	4	2.000	2.5000-12 UN-3B	AND10050-32R	AND10050-32RA	402534	402634

Thread mills are available. See pages 8-18.

[Go to Port Tool Overview](#)

TAPERED PIPE REAMERS (NPT) - CARBIDE TIPPED

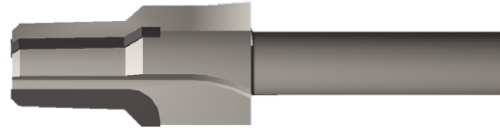
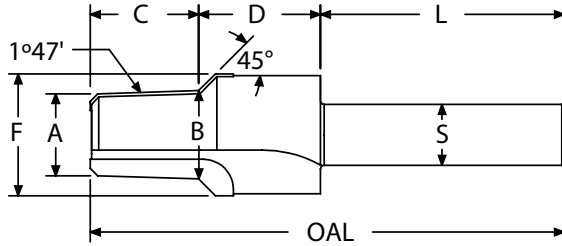

- Reams minor thread diameter on a taper
- Cuts 45° chamfer for easy threading
- ALTiN+ coating for higher cutting speed
- Carbide inserts made with premium submicron carbide

A	B	C	D	F	L	S	OAL	FLUTES	THREAD	ORDER #		EDP #	
										UNCOATED	ALTiN+	UNCOATED	ALTiN+
0.318	0.347	0.467	0.625	0.625	1.50	0.500	2.60	3	1/8-27NPT	PRSS-01	PRSS-01A	402701	402741
0.409	0.450	0.655	0.750	0.750	1.50	0.500	2.91	3	1/4-18NPT	PRSS-02	PRSS-02A	402704	402744
0.543	0.586	0.687	0.750	0.875	2.00	0.500	3.44	3	3/8-18NPT	PRSS-03	PRSS-03A	402707	402747
0.670	0.725	0.875	1.000	1.000	2.00	0.500	3.88	3	1/2-14NPT	PRSS-04	PRSS-04A	402710	402750
0.882	0.937	0.875	1.250	1.250	2.50	1.000	4.62	5	3/4-14NPT	PRSS-05	PRSS-05A	402713	402753
1.107	1.173	1.060	1.500	1.500	2.50	1.000	5.06	5	1-11.5NPT	PRSS-06	PRSS-06A	402716	402756
1.448	1.518	1.125	1.500	1.875	3.00	1.250	5.62	5	1¼-11.5NPT	PRSS-07	PRSS-07A	402719	402759
1.687	1.757	1.125	1.750	2.125	3.00	1.250	5.88	5	1½-11.5NPT	PRSS-08	PRSS-08A	402722	402762
2.154	2.230	1.220	2.000	2.625	3.00	1.250	6.22	5	2-11.5NPT	PRSS-09	PRSS-09A	402725	402765
2.561	2.670	1.750	2.000	3.125	3.00	1.250	6.75	5	2½-8NPT	PRSS-10	PRSS-10A	402728	402768
3.180	3.296	1.875	2.000	3.750	3.00	1.250	6.88	5	3-8NPT	PRSS-11	PRSS-11A	402731	402771

Thread mills are available. See pages 19-21.

[Go to Port Tool Overview](#)

RPT (AS1300) (PS10035) - ROSAN CAVITY PORT TOOL CARBIDE TIPPED

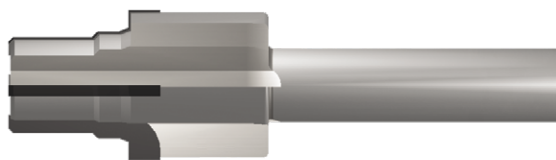
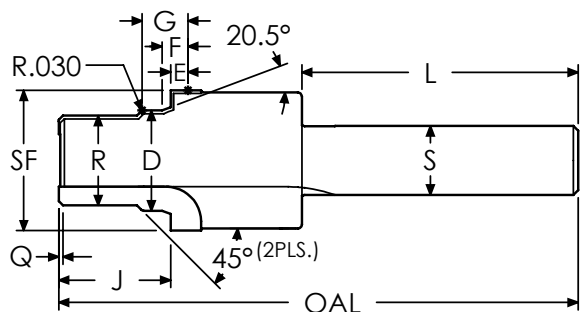

- Polished flute face for optimum performance
- Bodies made with heat-treated alloy steel
- Meets requirements of PS10035, AS1300, AS4201, and 6M152
- Precision ground for maximum concentricity
- ALTiN+ coating extends tool life

D	E	F	G	J	R	SF	L	S	OAL	FLUTES	TUBE	THREAD	ORDER #		EDP #	
													UNCOATED	ALTiN+	UNCOATED	ALTiN+
0.255	0.093	0.1555	0.2985	0.610	0.184	0.382	2.00	0.500	3.50	3	0.125	0.2160-28 UNJF-3B	Solid Carbide			
													RPT-2	RPT-2A	402910	402966
0.287	0.093	0.1555	0.2985	0.670	0.218	0.449	2.00	0.500	4.00	3	0.188	0.2500-28 UNJF-3B	RPT-3	RPT-3A	402919	402969
0.340	0.093	0.1555	0.2985	0.700	0.275	0.496	2.00	0.500	4.00	3	0.250	0.3125-24 UNJF-3B	RPT-4	RPT-4A	402922	402972
0.402	0.093	0.1555	0.2985	0.725	0.337	0.602	2.00	0.500	3.48	3	0.312	0.3750-24 UNJF-3B	Carbide Tipped			
													RPT-5	RPT-5A	402925	402975
0.465	0.108	0.1705	0.3135	0.785	0.392	0.676	2.00	0.500	3.53	4	0.375	0.4375-20 UNJF-3B	RPT-6	RPT-6A	402928	402978
0.583	0.108	0.1705	0.3135	0.850	0.511	0.785	2.00	0.500	3.85	4	0.500	0.5625-18 UNJF-3B	RPT-8	RPT-8A	402931	402981
0.726	0.108	0.1705	0.3135	0.810	0.650	1.016	2.00	0.500	3.81	4	0.625	0.6875-24 UNJEF-3B	RPT-10	RPT-10A	402901	402951
0.900	0.108	0.1705	0.3455	0.950	0.767	1.140	2.00	0.750	4.20	4	0.750	0.8125-20 UNJEF-3B	RPT-12	RPT-12A	402904	402954
1.163	0.108	0.1705	0.3455	1.015	1.073	1.428	2.00	0.750	4.26	4	1.000	1.1250-18 UNJEF-3B	RPT-16	RPT-16A	402907	402957
1.388	0.135	0.1975	0.3775	1.020	1.261	1.751	2.00	0.750	4.52	4	1.250	1.3125-18 UNJEF-3B	RPT-20	RPT-20A	402913	402960
1.665	0.135	0.1975	0.3775	1.205	1.574	2.002	0.750	2.00	4.52	4	1.500	1.6250-18 UNJEF-3B	RPT-24	RPT-24A	402916	402963

Thread mills are available. See pages 7-18.

[Go to Port Tool Overview](#)

RFPT - ROSAN CAVITY PORT TOOL CARBIDE TIPPED

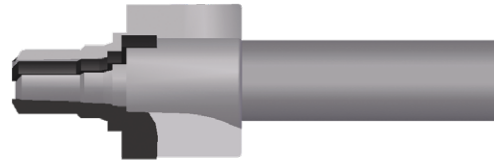
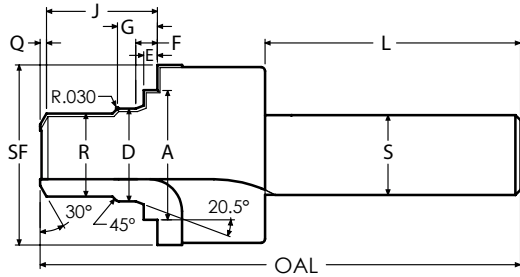

- Polished flute face for optimum performance
- Bodies made with heat-treated alloy steel
- Meets requirements of PS10035, AS1300, AS4201, and 6M152
- Precision ground for maximum concentricity
- ALTiN+ coating extends tool life

A	D	R	SF	E	F	G	J	Q	L	S	OAL	FLUTES	TUBE	THREAD	ORDER #		EDP #	
															UNCOATED	ALTiN+	UNCOATED	ALTiN+
Solid Carbide																		
0.382	0.255	0.184	0.590	0.093	0.1555	0.2985	0.602	0.015	2.00	0.500	3.38	3	0.125	0.2160-28 UNJF-3B	RFPT-02	RFPT-02A	403001	403051
0.449	0.287	0.218	0.728	0.093	0.1555	0.2985	0.663	0.015	2.00	0.500	3.38	3	0.188	0.2500-28 UNJF-3B	RFPT-03	RFPT-03A	403004	403054
Carbide Tipped																		
0.496	0.340	0.275	0.797	0.093	0.1555	0.2985	0.678	0.025	2.00	0.500	3.50	3	0.250	0.3125-24 UNJF-3B	RFPT-04	RFPT-04A	403007	403057
0.602	0.402	0.337	0.924	0.093	0.1555	0.2985	0.708	0.708	2.00	0.500	3.50	3	0.312	0.375-24 UNJF-3B	RFPT-05	RFPT-05A	403010	403060
0.676	0.465	0.392	0.995	0.108	0.1705	0.3135	0.734	0.050	2.00	0.500	3.50	3	0.375	0.4375-20 UNJF-3B	RFPT-06	RFPT-06A	403013	403063
0.785	0.583	0.511	1.211	0.108	0.1705	0.3135	0.798	0.050	2.00	0.500	3.50	3	0.500	0.5625-18 UNJF-3B	RFPT-08	RFPT-08A	403016	403066
1.016	0.726	0.650	1.355	0.108	0.1705	0.3135	0.828	0.060	2.00	0.750	3.85	4	0.625	0.6875-24 UNJEF-3B	RFPT-10	RFPT-10A	403019	403069
1.140	0.900	0.767	1.643	0.108	0.1705	0.3455	0.898	0.080	2.00	0.750	4.00	4	0.750	0.8125-20 UNJEF-3B	RFPT-12	RFPT-12A	403022	403072
1.312	1.031	0.892	1.780	0.108	0.1705	0.3455	0.935	0.090	2.25	1.000	4.25	4	0.875	0.9375-20 UNJEF-3B	RFPT-14	RFPT-14A	403025	403075
1.428	1.163	1.073	1.930	0.108	0.1705	0.3455	1.008	0.100	2.25	1.000	4.50	4	1.000	1.1250-18 UNJEF-3B	RFPT-16	RFPT-16A	403028	403078
1.751	1.388	1.261	2.298	0.135	0.1975	0.3775	1.040	0.120	2.25	1.000	4.50	4	1.250	1.3125-18 UNJEF-3B	RFPT-20	RFPT-20A	403031	403081
2.002	1.665	1.574	2.591	0.135	0.1975	0.3775	1.131	0.120	2.25	1.000	4.50	4	1.500	1.6250-18 UNJEF-3B	RFPT-24	RFPT-24A	403034	403084
2.518	2.203	2.064	3.500	0.135	0.2385	0.4185	1.338	0.120	2.50	1.250	5.00	4	2.000	2.1250-16 UNJ-3B	RFPT-32	RFPT-32A	403037	403087

Thread mills are available. See pages 7-18.

[Go to Port Tool Overview](#)

MS33514 (AS33514) - PORT TOOL CARBIDE

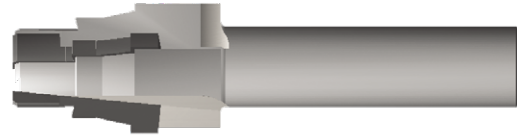
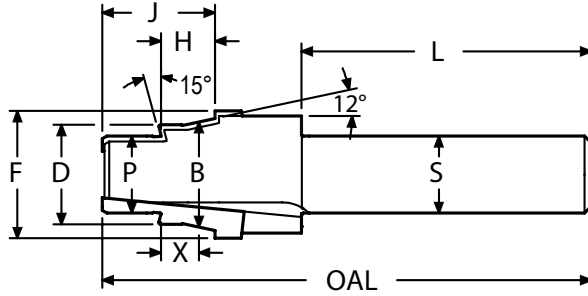

- Meets the requirements of the MS33514
- Precision ground for maximum concentricity
- ALTiN+ coating for higher cutting speed
- Polished flute face for optimum performance
- Also meets the requirements of MS33515, AS33515, AS4375, NAS1214, and NAS1215

B	D	F	H	J	P	X	L	S	OAL	FLUTES	TUBE	THREAD	ORDER #		EDP #	
													UNCOATED	ALTiN+	UNCOATED	ALTiN+
													Solid Carbide			
0.163	0.137	0.300	0.188	0.380	0.091	0.128	2.00	0.375	3.00	3	0.125	0.3125-24 UNJF-3A	MS33514-2	MS33514-2A	403110	403166
0.234	0.198	0.375	0.234	0.460	0.123	0.158	2.00	0.375	3.00	3	0.188	0.3750-24 UNJF-3A	MS33514-3	MS33514-3A	403119	403172
0.293	0.263	0.415	0.234	0.460	0.185	0.174	2.00	0.500	3.00	3	0.250	0.4375-20 UNJF-3A	MS33514-4	MS33514-4A	403125	403175
0.356	0.326	0.475	0.250	0.480	0.232	0.190	2.00	0.500	3.00	3	0.312	0.5000-20 UNJF-3A	MS33514-5	MS33514-5A	403128	403178
0.416	0.388	0.530	0.250	0.480	0.295	0.193	2.00	0.500	3.00	3	0.375	0.5625-18 UNJF-3A	MS33514-6	MS33514-6A	403131	403181
													Carbide Tipped			
0.560	0.516	0.690	0.305	0.675	0.420	0.210	1.88	0.500	3.00	3	0.500	0.7500-16 UNJF-3A	MS33514-8	MS33514-8A	403134	403184
0.686	0.643	0.825	0.350	0.725	0.498	0.255	1.88	0.500	3.15	3	0.625	0.8750-14 UNJF-3A	MS33514-10	MS33514-10A	403101	403151
0.810	0.768	1.000	0.350	0.775	0.654	0.253	1.88	0.500	3.23	3	0.750	1.0625-12 UNJ-3A	MS33514-12	MS33514-12A	403104	403154
1.062	1.018	1.250	0.415	0.915	0.873	0.322	2.00	0.750	3.50	4	1.000	1.3125-12 UNJ-3A	MS33514-16	MS33514-16A	403107	403157
1.316	1.272	1.560	0.415	0.925	1.091	0.325	2.00	0.750	3.62	4	1.250	1.6250-12 UNJ-3A	MS33514-20	MS33514-20A	403113	403160
1.565	1.522	1.800	0.485	0.925	1.342	0.390	2.12	1.000	3.82	4	1.500	1.8750-12 UNJ-3A	MS33514-24	MS33514-24A	403116	403163
2.068	2.024	2.400	0.485	0.925	1.811	0.395	2.25	1.000	4.09	4	2.000	2.5000-12 UNJ-3A	MS33514-32	MS33514-32A	403122	403169

Thread mills are available. See page 9.

[Go to Port Tool Overview](#)

MS21921 - PORT TOOL - CARBIDE TIPPED

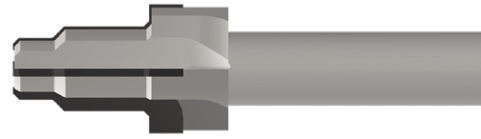
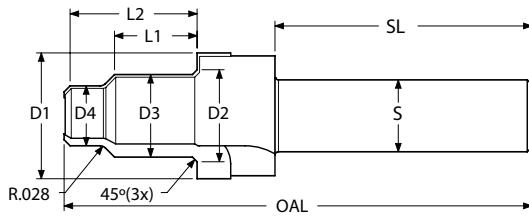

- ALTiN+ coating extends tool life
- Polished flute face for optimum performance
- Precision ground for maximum concentricity
- Bodies made with head treated alloy steel

D1	D2	D3	D4	L1	L2	S	SL	OAL	FLUTES	TUBE	THREAD	ORDER #		EDP#	
												UNCOATED	ALTiN+	UNCOATED	ALTiN+
0.400	0.328	0.277	0.173	0.425	0.570	0.500	1.75	3.00	3	0.125	0.3125-24 UNJF-3B	Solid Carbide			
												MS21921-2	MS21921-2A	403310	403363
0.475	0.391	0.338	0.234	0.429	0.625	0.500	1.75	3.00	3	0.187	0.3750-24 UNJF-3B	MS21921-3	MS21921-3A	403316	403366
0.600	0.460	0.393	0.393	0.547	0.760	0.500	1.75	3.25	3	0.250	0.4375-20 UNJF-3B	Carbide Tipped			
												MS21921-4	MS21921-4A	403319	403369
0.675	0.520	0.455	0.368	0.562	0.800	0.500	1.75	3.25	3	0.312	0.5000-20 UNJF-3B	MS21921-5	MS21921-5A	403322	403372
0.750	0.582	0.513	0.427	0.578	0.840	0.500	1.75	3.25	4	0.375	0.5625-18 UNJF-3B	MS21921-6	MS21921-6A	403325	403375
0.900	0.770	0.693	0.554	0.609	0.900	0.500	1.75	3.50	4	0.500	0.7500-16 UNJF-3B	MS21921-8	MS21921-8A	403328	403378
1.050	0.895	0.810	0.692	0.687	1.020	0.750	2.00	3.75	4	0.625	0.8750-14 UNJF-3B	MS21921-10	MS21921-10A	403301	403351
1.300	1.082	0.987	0.828	0.687	1.040	0.750	2.13	4.00	4	0.750	1.0625-12 UNJF-3B	MS21921-12	MS21921-12A	403304	403354
1.550	1.332	1.236	1.076	0.687	1.090	1.000	2.25	4.25	4	1.000	1.3125-12 UNJF-3B	MS21921-16	MS21921-16A	403307	403357
2.050	1.645	1.549	1.332	0.678	1.080	1.000	2.38	4.50	4	1.250	1.6250-12 UNJF-3B	MS21921-20	MS21921-20A	403313	403360

Thread mills are available. See pages 8-18.

[Go to Port Tool Overview](#)

PORT & CAVITY TECHNICAL INFORMATION

MATERIAL	HB/Rc	SPEED (SFM)		CUTTING CONDITIONS	
		UNCOATED	ALTiN+	INFEEED PER FLUTE REAM	INFEEED PER FLUTE SPOT FACE
CAST IRON	130 HB	75-210	200-450	.001-.0025	.0008-.0020
CARBON STEEL	18 Rc	125-190	190-400	.001-.0030	.001-.0020
ALLOY STEEL	20 Rc	70-135	130-350	.001-.0030	.0008-.0020
TOOL STEEL	25 Rc	75-100	100-220	.001-.0025	.0005-.0020
300 STAINLESS STEEL	150 HB	90-100	100-230	.001-.0020	.0007-.0015
400 STAINLESS STEEL	195 HB	90-135	135-300	.001-.0020	.0005-.0015
HIGH TEMP ALLOY (NICKEL & COBALT BASE)	20 Rc	30-125	100-150	.0008-.0015	.0005-.0010
TITANIUM	25 Rc	50-100	100-140	.001-.0020	.0005-.0010
HEAT TREATED ALLOYS (38-45Rc)	40 Rc	50-75	75-130	.0008-.0015	.0005-.0010
ALUMINUM	100 HB	850-1000	800-1500	.002-.0040	.0010-.0030
BRASS, ZINC	80 HB	750-950	800-1200	.002-.0040	.0010-.0030

SFM = Surface Feet per Minute

RPM = SFM x 3.82 divided by tool diameter

Starting parameters only. Setup and machine rigidity may affect performance.

PROBLEM	CAUSE	SOLUTION
RAPID FLANK WEAR	CUTTING CONDITIONS	Check for excessive speed and feed - see chart.
	TOOL	Select a coated tool.
	PROGRAM	Remove dwell from program at end of cut.
BUILT-UP EDGE	TOOL	Select a coated tool. The coating will resist built-up edges.
	HEAT	Use coolant through port tool. If coolant is not available, use shop air and a coated tool.
SURFACE TORN	TOOL	Use a coated tool. On most carbon steels, an uncoated tool will not produce an acceptable finish.
CHATTER	TOOL	Hone cutting edge of spot face. Use Coated Tool. Increase chip load.
LIGHT CHATTER	PROGRAM	Increase speed by 15-20%. A faster speed reduces forces. A dwell typically will not remove chatter.
POOR TOOL LIFE	AMOUNT OF STOCK	Rough port to 0.97 inch of finish size.
	PART	Make sure prior operation did not work harden the material.

SAMPLE PROGRAM FOR MAXIMUM PRODUCTIVITY

N51 (Sample Port Tool Program: MS33649-4RA (ALTiN+) cutting Carbon Steel

T51 M06

Select Tool

S2916 M03

SFM = 300 ; RPM = 300 x 3.82 / Reamer Diameter

G00 G90 G54 X0. Y0.

RPM = 300 X 3.82 / 0.393

G43 H51 Z0.1 M08

RPM = 2916

G01 Z-0.6 F23.3

Feed Rate = RPM x 0.002 x 4 (Number of Flutes)

S1290 M03

RPM = 300 x 3.82 / 0.888 (Spot Face Diameter)

G04 P1.

Dwell to slow down spindle

G01 Z-.73 F10.3

Feed rate = RPM x 0.002 x 4 (Number of Flutes)

G00 Z5. M09



CAVITY TOOLS



Eaton Vickers Roughers & Finishers
Parker Common Cavity Roughers & Finishers
Hydraforce Roughers & Finishers
Sun Hydraulic Roughers, Drills & Finishers

CAVITY TOOL PRODUCT OVERVIEW

All Cavity Tools are ground between centers to ensure absolute concentricity. They are made from heat-treated alloy steel with brazed carbide inserts. They are designed to enlarge a pre-drilled hole and easily produce a complex form. Cavity Tools can be used for both lathe and mill applications. Technical information available on page 108.

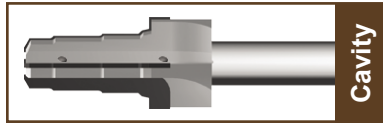

Parker Common Cavity (p.111-112)
Parker Common Cavity tools are carbide tipped and are stocked in both roughing and finishing versions.

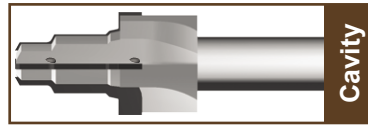

Hydraforce (p.113-114)
Hydraforce (VC) carbide tipped cavity tools are stocked in both roughing and finishing versions.

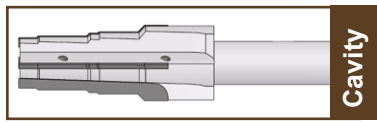

Sun Hydraulic (p.115-116)
Sun Hydraulic cavity tools are stocked in both HSS roughing step drills and carbide tipped finishing and roughing versions.

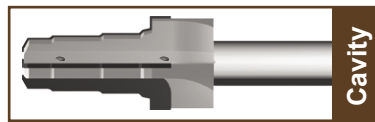

Eaton Vickers (p.117-118)
Eaton Vickers cavity tools are carbide tipped and stocked in both roughing and finishing versions.

CAVITY TOOL TECHNICAL INFORMATION PAGE 108

PARKER COMMON CAVITY TOOLS

ROUGHER - CARBIDE TIPPED

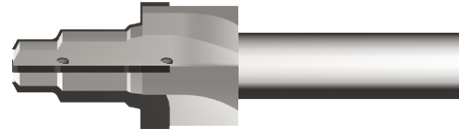
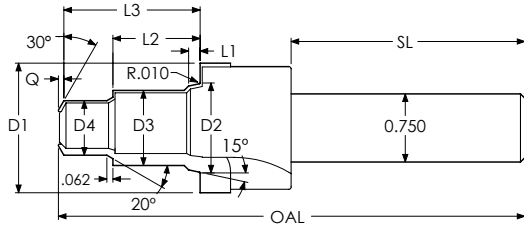

Coolant Hole(s) Each Flute

TWO WAY CAVITY

D1	D2	D3	D4	L1	L2	L3	Q	OAL	SL	ORDER #		EDP #	
										UNCOATED	ALTiN+	UNCOATED	ALTiN+
1.163	0.789	0.663	0.476	0.108	0.750	1.156	0.050	4.00	2.00	C08-2-ROUGH-X8	C08-2-ROUGH-X8A	400202	400238
1.319	0.920	0.787	0.601	0.108	0.965	1.332	0.060	4.00	2.00	C10-2-ROUGH-X8	C10-2-ROUGH-X8A	400211	400247
1.600	1.126	0.951	0.851	0.138	1.182	1.678	0.075	5.25	2.25	C12-2-ROUGH-X8	C12-2-ROUGH-X8A	400220	400256
1.885	1.376	1.209	1.102	0.138	1.344	1.864	0.075	5.50	2.25	C16-2-ROUGH-X8	C16-2-ROUGH-X8A	400229	400265

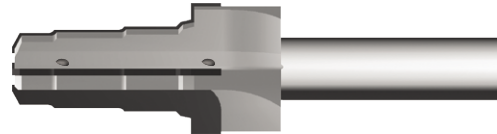
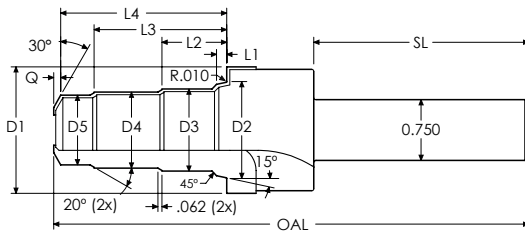

Coolant Hole(s) Each Flute

THREE WAY CAVITY

D1	D2	D3	D4	D5	L1	L2	L3	L4	Q	OAL	SL	ORDER #		EDP #	
												UNCOATED	ALTiN+	UNCOATED	ALTiN+
1.163	0.789	0.663	0.601	0.538	0.108	0.680	1.240	1.750	0.060	5.00	2.12	C08-3-ROUGH-X8	C08-3-ROUGH-X8A	400205	400241
1.319	0.920	0.787	0.664	0.601	0.108	0.850	1.500	1.895	0.050	5.00	2.12	C10-3-ROUGH-X8	C10-3-ROUGH-X8A	400214	400250
1.600	1.126	0.950	0.913	0.851	0.138	1.062	1.908	2.346	0.070	5.75	2.12	C12-3-ROUGH-X8	C12-3-ROUGH-X8A	400223	400259
1.885	1.376	1.209	1.102	1.039	0.138	1.344	2.469	2.988	0.065	6.25	2.12	C16-3-ROUGH-X8	C16-3-ROUGH-X8A	400232	400268

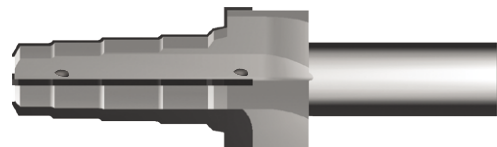
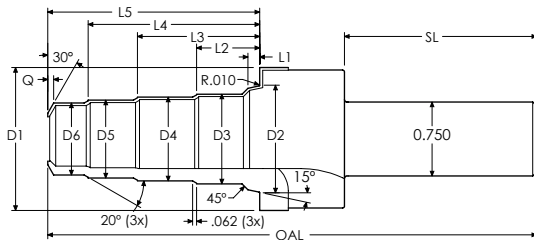

Coolant Hole(s) Each Flute

FOUR WAY CAVITY

D1	D2	D3	D4	D5	D6	L1	L2	L3	L4	L5	Q	OAL	SL	ORDER #		EDP #	
														UNCOATED	ALTiN+	UNCOATED	ALTiN+
1.163	0.789	0.663	0.601	0.538	0.476	0.108	0.680	1.240	1.797	2.150	0.050	5.50	2.12	C08-4-ROUGH-X8	C08-4-ROUGH-X8A	400208	400244
1.319	0.920	0.787	0.726	0.664	0.601	0.108	0.875	1.500	2.125	2.520	0.055	5.50	2.12	C10-4-ROUGH-X8	C10-4-ROUGH-X8A	400217	400253
1.600	1.126	0.950	0.913	0.851	0.789	0.138	1.062	1.908	2.758	3.196	0.070	7.00	2.25	C12-4-ROUGH-X8	C12-4-ROUGH-X8A	400226	400262
1.885	1.376	1.209	1.102	1.039	0.977	0.138	1.344	2.469	3.594	4.096	0.070	7.25	2.25	C16-4-ROUGH-X8	C16-4-ROUGH-X8A	400235	400271

[Go to Cavity Tool Overview](#)

PARKER COMMON CAVITY TOOLS

FINISHER - CARBIDE TIPPED

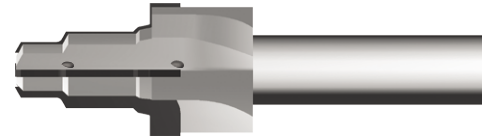
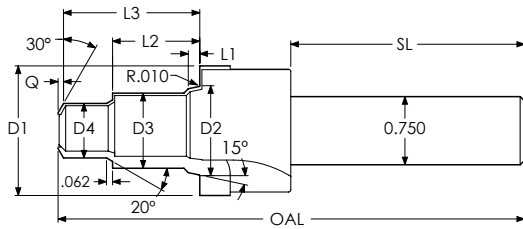

Coolant Hole(s) Each Flute

TWO WAY CAVITY

D1	D2	D3	D4	L1	L2	L3	Q	OAL	SL	ORDER #		EDP #	
										UNCOATED	ALTiN+	UNCOATED	ALTiN+
1.188	0.813	0.688	0.501	0.108	0.750	1.156	0.050	4.00	2.00	C08-2-FINISH-X8	C08-2-FINISH-X8A	400201	400237
1.344	0.945	0.812	0.626	0.108	0.965	1.332	0.060	4.00	2.00	C10-2-FINISH-X8	C10-2-FINISH-X8A	400210	400246
1.625	1.150	0.976	0.876	0.138	1.182	1.678	0.075	5.25	2.25	C12-2-FINISH-X8	C12-2-FINISH-X8A	400219	400255
1.910	1.401	1.234	1.127	0.138	1.344	1.864	0.075	5.50	2.25	C16-2-FINISH-X8	C16-2-FINISH-X8A	400228	400264

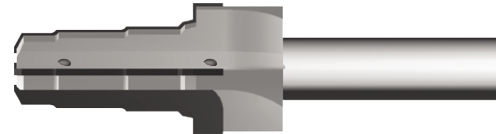
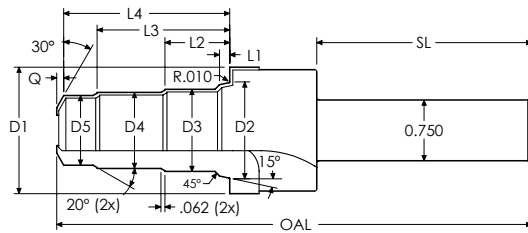

Coolant Hole(s) Each Flute

THREE WAY CAVITY

D1	D2	D3	D4	D5	L1	L2	L3	L4	Q	OAL	SL	ORDER #		EDP #	
												UNCOATED	ALTiN+	UNCOATED	ALTiN+
1.188	0.813	0.688	0.626	0.563	0.108	0.680	1.240	1.750	0.060	5.00	2.12	C08-3-FINISH-X8	C08-3-FINISH-X8A	400204	400240
1.344	0.945	0.812	0.689	0.626	0.108	0.850	1.500	1.895	0.050	5.00	2.12	C10-3-FINISH-X8	C10-3-FINISH-X8A	400213	400249
1.625	1.150	0.975	0.938	0.876	0.138	1.062	1.908	2.346	0.070	5.75	2.12	C12-3-FINISH-X8	C12-3-FINISH-X8A	400222	400258
1.910	1.401	1.234	1.127	1.064	0.138	1.344	2.469	2.988	0.065	6.25	2.12	C16-3-FINISH-X8	C16-3-FINISH-X8A	400231	400267

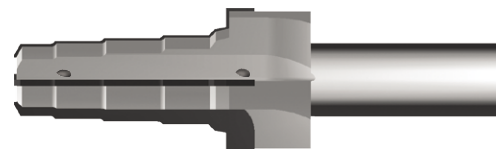
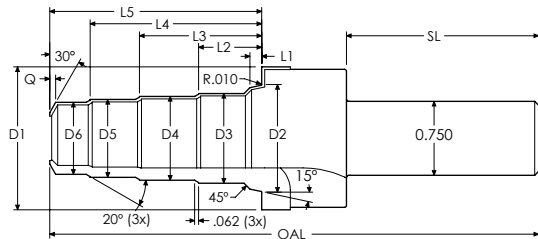

Coolant Hole(s) Each Flute

FOUR WAY CAVITY

D1	D2	D3	D4	D5	D6	L1	L2	L3	L4	L5	Q	OAL	SL	ORDER #		EDP #	
														UNCOATED	ALTiN+	UNCOATED	ALTiN+
1.188	0.813	0.688	0.626	0.563	0.501	.108	0.680	1.240	1.797	2.150	.050	5.50	2.12	C08-4-FINISH-X8	C08-4-FINISH-X8A	400207	400243
1.344	0.945	0.812	0.751	0.689	0.626	.108	0.875	1.500	2.125	2.520	.055	5.50	2.12	C10-4-FINISH-X8	C10-4-FINISH-X8A	400216	400252
1.625	1.150	0.975	0.938	0.876	0.814	.138	1.062	1.908	2.758	3.196	.070	7.00	2.25	C12-4-FINISH-X8	C12-4-FINISH-X8A	400225	400261
1.910	1.401	1.234	1.127	1.064	1.002	.138	1.344	2.469	3.594	4.096	.070	7.25	2.25	C16-4-FINISH-X8	C16-4-FINISH-X8A	400234	400270

[Go to Cavity Tool Overview](#)

HYDRAFORCE CARTRIDGE VALVE TOOLS ROUGHER - CARBIDE TIPPED

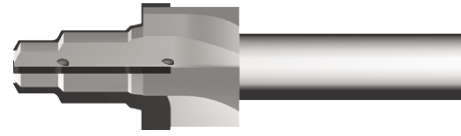
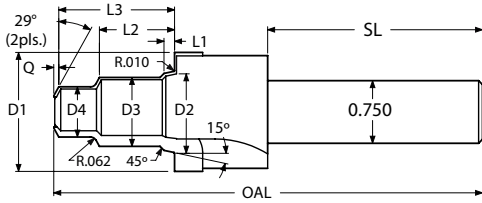

Coolant Hole(s) Each Flute

TWO WAY CAVITY

D1	D2	D3	D4	L1	L2	L3	Q	OAL	SL	ORDER #		EDP #	
										UNCOATED	ALTiN+	UNCOATED	ALTiN+
1.163	0.788	0.663	0.476	0.108	0.750	1.156	0.045	4.00	2.00	VC08-2-ROUGH-X8	VC08-2-ROUGH-X8A	400901	400951
1.163	0.920	0.787	0.601	0.108	0.932	1.312	0.060	4.00	2.25	VC10-2-ROUGH-X8	VC10-2-ROUGH-X8A	400910	400960
1.475	1.125	0.952	0.851	0.138	1.400	1.920	0.075	5.25	2.25	VC12-2-ROUGH-X8	VC12-2-ROUGH-X8A	400919	400969
1.725	1.376	1.209	1.102	0.138	1.344	1.844	0.075	5.50	2.25	VC16-2-ROUGH-X8	VC16-2-ROUGH-X8A	400928	400978

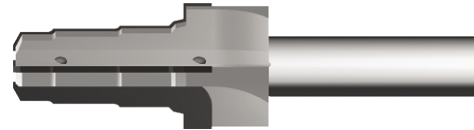
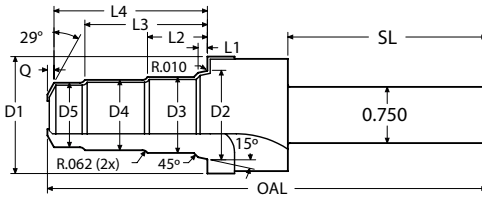

Coolant Hole(s) Each Flute

THREE WAY CAVITY - COOLANT THROUGH

D1	D2	D3	D4	L1	L2	L3	Q	OAL	SL	ORDER #		EDP #	
										UNCOATED	ALTiN+	UNCOATED	ALTiN+
1.163	0.788	0.663	0.476	0.108	0.750	1.270	0.060	5.00	2.12	VC08-3-ROUGH-X8	VC08-3-ROUGH-X8A	400904	400954
1.163	0.920	0.787	0.601	0.108	0.860	1.500	0.050	5.00	2.12	VC10-3-ROUGH-X8	VC10-3-ROUGH-X8A	400913	400963
1.475	1.125	0.952	0.851	0.138	1.400	2.370	0.070	6.25	2.12	VC12-3-ROUGH-X8	VC12-3-ROUGH-X8A	400922	400972
1.725	1.376	1.209	1.102	0.138	1.344	2.469	0.065	6.25	2.12	VC16-3-ROUGH-X8	VC16-3-ROUGH-X8A	400931	400981

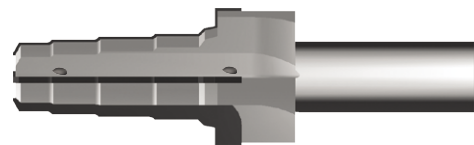
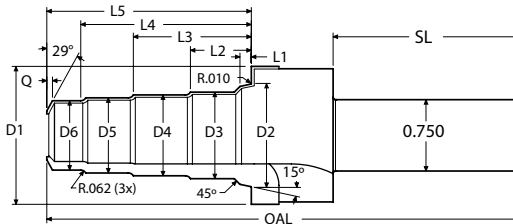

Coolant Hole(s) Each Flute

FOUR WAY CAVITY - COOLANT THROUGH

D1	D2	D3	D4	L1	L2	L3	Q	OAL	SL	ORDER #		EDP #	
										UNCOATED	ALTiN+	UNCOATED	ALTiN+
1.163	0.788	0.663	0.601	0.538	0.718	1.270	0.050	5.50	2.12	VC08-4-ROUGH-X8	VC08-4-ROUGH-X8A	400907	400957
1.163	0.920	0.787	0.726	0.664	0.870	1.500	0.045	5.50	2.12	VC10-4-ROUGH-X8	VC10-4-ROUGH-X8A	400916	400966
1.475	1.125	0.950	0.913	0.851	1.400	3.860	0.070	7.00	2.25	VC12-4-ROUGH-X8	VC12-4-ROUGH-X8A	400925	400975
1.725	1.376	1.209	1.102	1.039	1.344	4.094	0.070	7.25	2.25	VC16-4-ROUGH-X8	VC16-4-ROUGH-X8A	400934	400984

[Go to Cavity Tool Overview](#)

HYDRAFORCE CARTRIDGE VALVE TOOLS

FINISHER - CARBIDE TIPPED

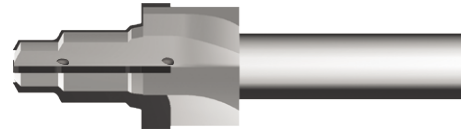
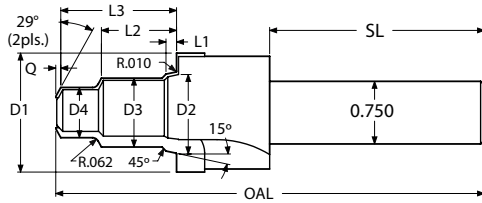

Coolant Hole(s) Each Flute

TWO WAY CAVITY - COOLANT THROUGH

D1	D2	D3	D4	L1	L2	L3	Q	OAL	SL	ORDER #		EDP #	
										UNCOATED	ALTIN+	UNCOATED	ALTIN+
1.188	0.813	0.688	0.501	0.108	0.750	1.156	0.050	4.00	2.00	VC08-2-FINISH-X8	VC08-2-FINISH-X8A	400561	400600
1.188	0.945	0.812	0.626	0.108	0.932	1.312	0.060	4.00	2.00	VC10-2-FINISH-X8	VC10-2-FINISH-X8A	400570	400609
1.500	1.150	0.977	0.876	0.138	1.400	1.920	0.075	5.25	2.25	VC12-2-FINISH-X8	VC12-2-FINISH-X8A	400579	400618
1.750	1.401	1.234	1.127	0.138	1.344	1.844	0.075	5.50	2.25	VC16-2-FINISH-X8	VC16-2-FINISH-X8A	400588	400627

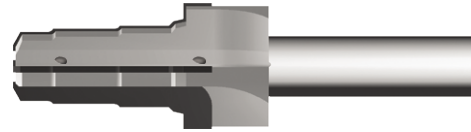
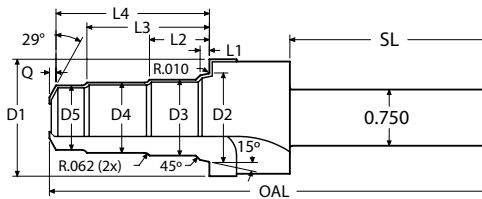

Coolant Hole(s) Each Flute

THREE WAY CAVITY - COOLANT THROUGH

D1	D2	D3	D4	D5	L1	L2	L3	L4	Q	OAL	SL	ORDER #		EDP #	
												UNCOATED	ALTIN+	UNCOATED	ALTIN+
1.188	0.813	0.688	0.626	0.563	0.108	0.718	1.270	1.703	0.060	5.00	2.12	VC08-3-FINISH-X8	VC08-3-FINISH-X8A	400564	400603
1.188	0.945	0.812	0.689	0.626	0.108	0.860	1.500	1.875	0.050	5.00	2.12	VC10-3-FINISH-X8	VC10-3-FINISH-X8A	400573	400612
1.500	1.150	0.975	0.938	0.876	0.138	1.400	2.370	2.890	0.070	6.25	2.12	VC12-3-FINISH-X8	VC12-3-FINISH-X8A	400582	400621
1.750	1.401	1.234	1.127	1.064	0.138	1.344	2.469	2.968	0.065	6.25	2.12	VC16-3-FINISH-X8	VC16-3-FINISH-X8A	400591	400630

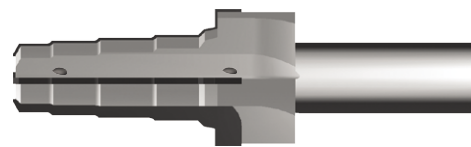
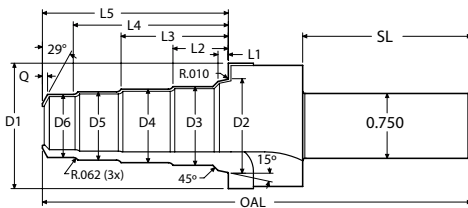

Coolant Hole(s) Each Flute

FOUR WAY CAVITY - COOLANT THROUGH

D1	D2	D3	D4	D5	D6	L1	L2	L3	L4	L5	Q	OAL	SL	ORDER #		EDP #	
														UNCOATED	ALTIN+	UNCOATED	ALTIN+
1.188	0.813	0.688	0.626	0.563	0.501	0.108	0.718	1.270	1.830	2.210	0.050	5.50	2.12	VC08-4-FINISH-X8	VC08-4-FINISH-X8A	400567	400606
1.188	0.945	0.812	0.751	0.689	0.626	0.108	0.870	1.500	2.125	2.500	0.055	5.50	2.12	VC10-4-FINISH-X8	VC10-4-FINISH-X8A	400576	400615
1.500	1.150	0.975	0.938	0.876	0.813	0.138	1.400	2.370	3.330	3.860	0.070	7.00	2.25	VC12-4-FINISH-X8	VC12-4-FINISH-X8A	400585	400624
1.750	1.401	1.234	1.127	1.064	1.002	0.138	1.344	2.469	3.594	4.094	0.070	7.25	2.25	VC16-4-FINISH-X8	VC16-4-FINISH-X8A	400594	400633

[Go to Cavity Tool Overview](#)

SUN HYDRAULIC CARTRIDGE VALVE TOOLS HIGH SPEED STEEL ROUGHING STEP DRILLS

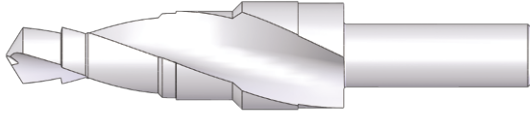

- Precision ground for maximum concentricity
- Prepares cavity for finish tool

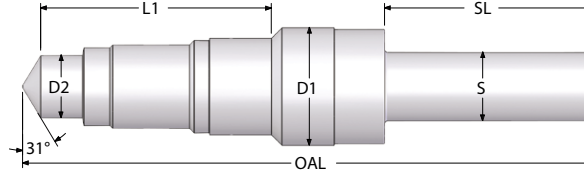

This illustration shows the largest and smallest diameter.
Visit website www.sct-usa.com for more details.

D1	D2	L1	S	SL	OAL	FLUTES	THREAD	ORDER #		EDP #	
								UNCOATED	ALTiN+	UNCOATED	ALTiN+
1.285	0.686	2.517	0.750	2.400	6.40	2	1.0-14UNS-2B	T-2A-DRILL	T-2A-DRILL-A	400701	400741
1.312	0.876	2.382	0.750	2.400	6.40	2	1.0-14UNS-2B	T-3A-DRILL	T-3A-DRILL-A	400704	400744
1.312	0.876	2.147	0.750	2.400	6.40	2	1.0-14UNS-2B	T-5A-DRILL	T-5A-DRILL-A	400707	400747
0.980	0.688	2.018	0.750	2.400	6.40	2	M20X1.5-6H	T-10A-DRILL	T-10A-DRILL-A	400710	400750
0.980	0.688	2.322	0.750	2.400	6.40	2	M20X1.5-6H	T-11A-DRILL	T-11A-DRILL-A	400713	400753
0.980	0.688	1.858	0.750	2.400	6.40	2	M20X1.5-6H	T-13A-DRILL	T-13A-DRILL-A	400716	400756
1.500	1.251	2.377	0.750	2.400	6.50	2	M36X2.0-6H	T-16A-DRILL	T-16A-DRILL-A	400719	400759
0.978	0.529	2.780	0.750	2.400	6.80	2	M20X1.5-6H	T-21A-DRILL	T-21A-DRILL-A	400722	400762
1.125	0.405	1.804	0.750	2.400	6.40	2	M16X1.5-6H	T-162A-DRILL	T-162A-DRILL-A	400725	400765
1.125	0.405	2.143	0.750	2.400	6.40	2	M16X1.5-6H	T-163A-DRILL	T-163A-DRILL-A	400728	400768

SUN HYDRAULIC CARTRIDGE VALVE TOOLS ROUGHER - CARBIDE TIPPED

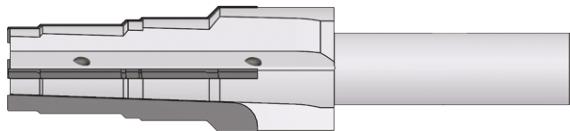

Coolant Hole(s) Each Flute

- ALTiN+ coating for higher cutting speed
- Polished flute face for optimum performance
- Precision ground for maximum concentricity

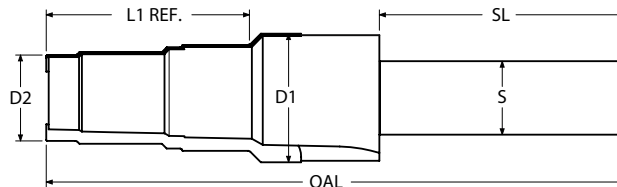

This illustration shows the largest and smallest diameter.
Visit website www.sct-usa.com for more details.

D1	D2	L1	S	SL	OAL	FLUTES	THREAD	ORDER #		EDP #	
								UNCOATED	ALTiN+	UNCOATED	ALTiN+
1.725	1.226	2.697	1.000	2.50	6.50	4	M36X2.0-6H	T-17A-ROUGH-X8	T-17A-ROUGH-X8A	400826	400876
2.038	1.601	3.135	1.000	2.50	6.88	4	M48X2.0-6H	T-18A-ROUGH-X8	T-18A-ROUGH-X8A	400829	400879

[Go to Cavity Tool Overview](#)

SUN HYDRAULIC CARTRIDGE VALVE TOOLS

FINISHER - CARBIDE TIPPED

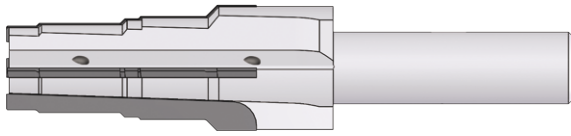

Coolant Hole(s) Each Flute

- ALTiN+ coating for higher cutting speed
- Polished flute face for optimum performance
- Precision ground for maximum concentricity

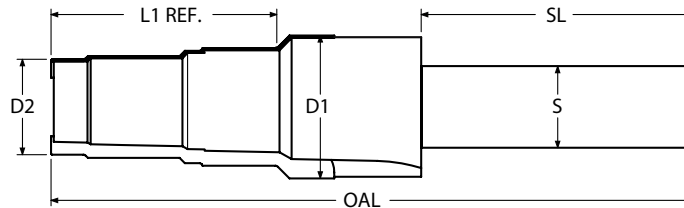

This illustration shows the largest and smallest diameter.
Visit website www.sct-usa.com for more details.

D1	D2	L1	S	SL	OAL	FLUTES	THREAD	ORDER #		EDP #	
								UNCOATED	ALTiN+	UNCOATED	ALTiN+
1.312	0.876	2.073	0.750	2.50	5.88	4	1.0-14UNS-2B	T-2A-FINISH-X8	T-2A-FINISH-X8A	400801	400851
1.709	0.876	1.885	0.750	2.25	5.38	4	1.0-14UNS-2B	T-3A-FINISH-X8	T-3A-FINISH-X8A	400804	400854
1.079	0.876	1.635	0.750	2.25	5.13	4	1.0-14UNS-2B	T-5A-FINISH-X8	T-5A-FINISH-X8A	400807	400857
0.704	0.438	0.752	0.500	2.00	4.00	4	M16X1.5-6H	T-8A-FINISH-X4	T-8A-FINISH-X4A	400810	400860
1.000	0.688	1.726	0.750	2.25	5.25	4	M20X1.5-6H	T-10A-FINISH-X8	T-10A-FINISH-X8A	400813	400863
1.000	0.688	2.036	0.750	2.25	5.50	4	M20X1.5-6H	T-11A-FINISH-X8	T-11A-FINISH-X8A	400816	400866
1.000	0.688	1.539	0.750	2.25	5.00	4	M20X1.5-6H	T-13A-FINISH-X8	T-13A-FINISH-X8A	400819	400869
1.563	1.251	2.448	1.000	2.25	6.00	4	M36X2.0-6H	T-16A-FINISH-X8	T-16A-FINISH-X8A	400822	400872
1.750	1.251	2.448	1.000	2.50	6.50	4	M36X2.0-6H	T-17A-FINISH-X8	T-17A-FINISH-X8A	400825	400875
2.063	1.626	3.135	1.000	2.50	6.88	4	M48X2.0-6H	T-18A-FINISH-X8	T-18A-FINISH-X8A	400828	400878
1.000	0.688	2.539	0.750	2.25	6.00	4	M20X1.5-6H	T-21A-FINISH-X8	T-21A-FINISH-X8A	400831	400881
0.938	0.516	1.377	0.750	2.25	4.88	4	M16X1.5-6H	T-162A-FINISH-X8	T-162A-FINISH-X8A	400681	400884
0.938	0.516	1.800	0.750	2.25	5.25	4	M16X1.5-6H	T-163A-FINISH-X8	T-163A-FINISH-X8A	400834	400887

[Go to Cavity Tool Overview](#)

EATON VICKERS CAVITY TOOLS

ROUGHERS - CARBIDE TIPPED

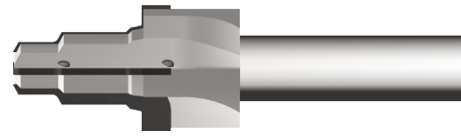
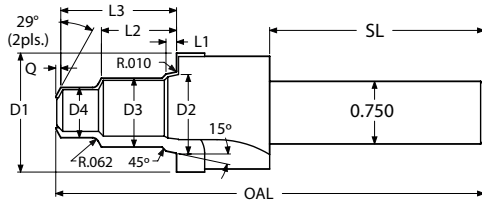

Coolant Hole(s) Each Flute

TWO WAY CAVITY

D1	D2	D3	D4	L1	L2	L3	Q	OAL	SL	ORDER #		EDP #	
										UNCOATED	ALTiN+	UNCOATED	ALTiN+
1.163	0.789	0.663	0.476	0.108	0.750	1.188	0.050	4.00	2.00	C-08-2-ROUGH-X8	C-08-2-ROUGH-X8A	400300	400302
1.163	0.920	0.787	0.601	0.108	0.934	1.312	0.060	4.00	2.00	C-10-2-ROUGH-X8	C-10-2-ROUGH-X8A	400312	400314
1.475	1.124	0.950	0.913	0.138	1.375	1.825	0.075	5.25	2.25	C-12-2-ROUGH-X8	C-12-2-ROUGH-X8A	400324	400326
1.725	1.376	1.209	1.102	0.138	1.344	1.844	0.075	5.50	2.25	C-16-2-ROUGH-X8	C-16-2-ROUGH-X8A	400336	400338

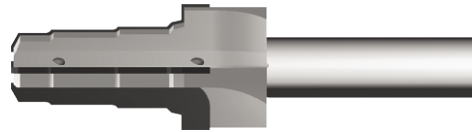
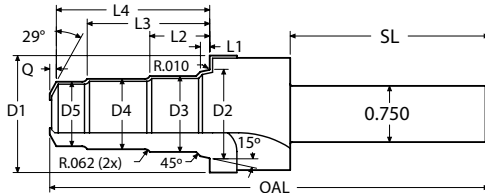

Coolant Hole(s) Each Flute

THREE WAY CAVITY

D1	D2	D3	D4	D5	L1	L2	L3	L4	Q	OAL	SL	ORDER #		EDP #	
												UNCOATED	ALTiN+	UNCOATED	ALTiN+
1.163	0.789	0.663	0.601	0.538	0.108	0.718	1.270	1.703	0.060	5.00	2.12	C-08-3-ROUGH-X8	C-08-3-ROUGH-X8A	400304	400306
1.163	0.920	0.787	0.664	0.601	0.108	0.850	1.500	1.875	0.060	5.00	2.12	C-10-3-ROUGH-X8	C-10-3-ROUGH-X8A	400316	400318
1.475	1.124	0.950	0.913	0.851	0.138	1.375	2.275	2.725	0.075	6.25	2.25	C-12-3-ROUGH-X8	C-12-3-ROUGH-X8A	400328	400330
1.725	1.376	1.209	1.102	1.039	0.138	1.344	2.469	2.968	0.110	6.25	2.12	C-16-3-ROUGH-X8	C-16-3-ROUGH-X8A	400340	400342

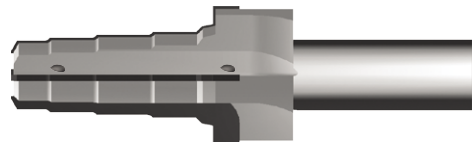
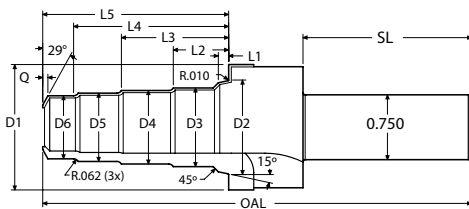

Coolant Hole(s) Each Flute

FOUR WAY CAVITY

D1	D2	D3	D4	D5	D6	L1	L2	L3	L4	L5	Q	OAL	SL	ORDER #		EDP #	
														UNCOATED	ALTiN+	UNCOATED	ALTiN+
1.163	0.789	0.663	0.601	0.538	0.476	0.108	0.718	1.270	1.830	2.210	0.050	5.50	2.12	C-08-4-ROUGH-X8	C-08-4-ROUGH-X8A	400308	400310
1.163	0.920	0.787	0.726	0.664	0.601	0.108	0.872	1.500	2.125	2.500	0.060	5.50	2.12	C-10-4-ROUGH-X8	C-10-4-ROUGH-X8A	400320	400322
1.475	1.124	0.950	0.913	0.851	0.788	0.138	1.375	2.275	3.175	3.625	0.075	7.00	2.25	C-12-4-ROUGH-X8	C-12-4-ROUGH-X8A	400332	400334
1.725	1.376	1.209	1.102	1.039	0.977	0.138	1.344	2.469	3.594	4.094	0.110	7.25	2.25	C-16-4-ROUGH-X8	C-16-4-ROUGH-X8A	400344	400346

[Go to Cavity Tool Overview](#)

EATON VICKERS CAVITY TOOLS

FINISHERS - CARBIDE TIPPED

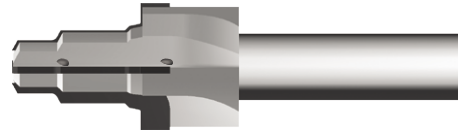
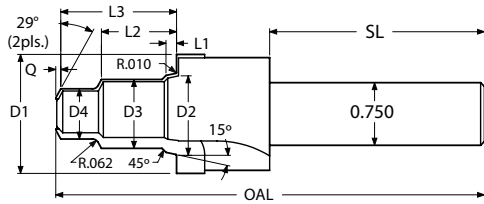

Coolant Hole(s) Each Flute

TWO WAY CAVITY

D1	D2	D3	D4	L1	L2	L3	Q	OAL	SL	ORDER #		EDP #	
										UNCOATED	ALTiN+	UNCOATED	ALTiN+
1.188	0.814	0.688	0.501	0.108	0.750	1.188	0.050	4.00	2.00	C-08-2-FINISH-X8	C-08-2-FINISH-X8A	400348	400350
1.188	0.946	0.812	0.626	0.108	0.934	1.312	0.060	4.00	2.00	C-10-2-FINISH-X8	C-10-2-FINISH-X8A	400360	400362
1.500	1.149	0.975	0.938	0.138	1.375	1.825	0.075	5.25	2.25	C-12-2-FINISH-X8	C-12-2-FINISH-X8A	400372	400374
1.750	1.401	1.234	1.127	0.138	1.344	1.844	0.075	5.50	2.25	C-16-2-FINISH-X8	C-16-2-FINISH-X8A	400384	400386

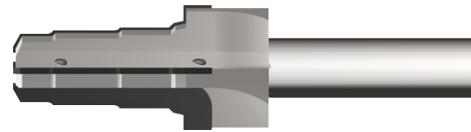
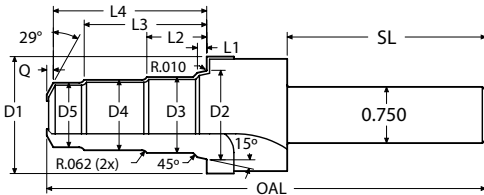

Coolant Hole(s) Each Flute

THREE WAY CAVITY

D1	D2	D3	D4	D5	L1	L2	L3	L4	Q	OAL	SL	ORDER #		EDP #	
												UNCOATED	ALTiN+	UNCOATED	ALTiN+
1.188	0.814	0.688	0.626	0.563	0.108	0.718	1.270	1.703	0.060	5.00	2.12	C-08-3-FINISH-X8	C-08-3-FINISH-X8A	400352	400354
1.188	0.945	0.812	0.689	0.626	0.108	0.850	1.500	1.875	0.060	5.00	2.12	C-10-3-FINISH-X8	C-10-3-FINISH-X8A	400364	400366
1.500	1.149	0.975	0.938	0.876	0.138	1.375	2.275	2.725	0.075	6.25	2.25	C-12-3-FINISH-X8	C-12-3-FINISH-X8A	400376	400378
1.750	1.401	1.234	1.127	1.064	0.138	1.344	2.469	2.968	0.110	6.25	2.12	C-16-3-FINISH-X8	C-16-3-FINISH-X8A	400388	400390

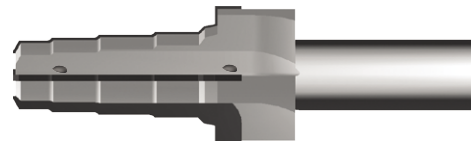
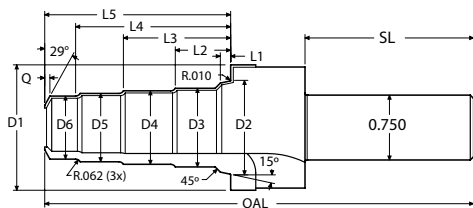

Coolant Hole(s) Each Flute

FOUR WAY CAVITY

D1	D2	D3	D4	D5	D6	L1	L2	L3	L4	L5	Q	OAL	SL	ORDER #		EDP #	
														UNCOATED	ALTiN+	UNCOATED	ALTiN+
1.188	0.814	0.688	0.626	0.563	0.501	0.108	0.718	1.270	1.830	2.210	0.050	5.50	2.12	C-08-4-FINISH-X8	C-08-4-FINISH-X8A	400356	400358
1.188	0.945	0.812	0.751	0.689	0.626	0.108	0.872	1.500	2.125	2.500	0.060	5.50	2.12	C-10-4-FINISH-X8	C-10-4-FINISH-X8A	400368	400370
1.500	1.149	0.975	0.938	0.876	0.813	0.138	1.375	2.275	3.175	3.625	0.075	7.00	2.25	C-12-4-FINISH-X8	C-12-4-FINISH-X8A	400380	400382
1.750	1.401	1.234	1.127	1.064	1.002	0.138	1.344	2.469	3.594	4.094	0.110	7.25	2.25	C-16-4-FINISH-X8	C-16-4-FINISH-X8A	400392	400394

[Go to Cavity Tool Overview](#)



SPECIALTY END MILL

Helical Chamfer Mill
Corner Rounding
Engraving Tool

SPECIALTY END MILL PRODUCT OVERVIEW

Specialty end mills feature the same premium submicron carbide as the rest of the product lines. They are ground on modern CNC tool-and-cutter grinders to tight tolerances and have been engineered for high performance.



Helical Chamfer Mills (p.121)

Helical Chamfer Mills are made to mill a chamfer on an edge. They come with either three or five helical flutes. The diameter sizes range from 1/8" to 3/4", and have included angles of 60, 90, and 120 degrees. The tools are not recommended for plunging countersinks.



Corner Rounding End Mills (p.122)

Corner Rounding End Mills have three flutes and are double ended to provide maximum value. The cutter diameter and the cut depth are held to ± 0.001 inch tolerance to provide ease of set-up.



Engraving Tools (p.123)

Engraving Tools come in a large variety of angles and sizes. These solid carbide tools will engrave on a large variety of materials. The tool tip is held to ± 0.001 inch tolerance for uniformity.

New Product
2020



Spotting Drills

Spotting drills are a valuable first step in the holmaking process. The tool is solid carbide with a precise point angle that is held to a one-degree tolerance for true centering. Covering a wide range of sizes, it is available in 82, 90, 100, 120 and 142 degree point angles.

New Product
2021



Drill Mills

Drill Mills are designed for milling, chamfering, and light spotting applications. They come with two or four helical flutes each offered in included angles of 90 or 120 degrees. The cutter diameter sizes range from 1/8" to 1/2".

SPECIALTY END MILL TECHNICAL INFORMATION PAGES 124-125

[Click here to view Helical Chamfer Mill in action](#)

HELICAL CHAMFER MILLS

HIGH PERFORMANCE - SOLID CARBIDE

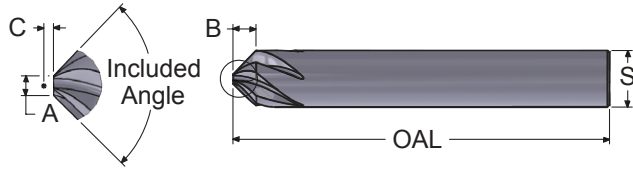

- Helical flutes for high performance
- Tool tip diameter held to + /- 0.002 for fast set-ups
- Positive high shear design for reduced cutting forces

Tool is not recommended for plunging countersinks

* C is the length from the tool tip to theoretical sharp

3 FLUTES FOR MAX CHIP EVACUATION

INCL. ANGLE	"S" SHANK DIA.	OAL	"A" TIP DIA.	"B" LENGTH OF CUT	"C" * REF.	FLUTES	ORDER #		EDP #	
							UNCOATED	ALTiN+	UNCOATED	ALTiN+
60°	0.125	1.50	0.040	0.074	0.036	3	HC12503-060	HC12503-060A	500010	500132
60°	0.187	2.00	0.050	0.119	0.045	3	HC18703-060	HC18703-060A	500013	500135
60°	0.250	2.50	0.060	0.165	0.054	3	HC25003-060	HC25003-060A	500017	500138
60°	0.375	2.50	0.070	0.264	0.062	3	HC37503-060	HC37503-060A	500023	500144
60°	0.500	3.00	0.080	0.364	0.071	3	HC50003-060	HC50003-060A	500030	500150
60°	0.625	3.00	0.090	0.463	0.080	3	HC62503-060	HC62503-060A	500037	500156
60°	0.750	3.00	0.100	0.563	0.088	3	HC75003-060	HC75003-060A	500043	500162
90°	0.125	1.50	0.040	0.043	0.021	3	HC12503-090	HC12503-090A	500050	500168
90°	0.187	2.00	0.050	0.069	0.026	3	HC18703-090	HC18703-090A	500054	500171
90°	0.250	2.50	0.060	0.095	0.031	3	HC25003-090	HC25003-090A	500057	500174
90°	0.375	2.50	0.070	0.153	0.036	3	HC37503-090	HC37503-090A	500064	500180
90°	0.500	3.00	0.080	0.210	0.041	3	HC50003-090	HC50003-090A	500071	500186
90°	0.625	3.00	0.090	0.268	0.046	3	HC62503-090	HC62503-090A	500077	500192
90°	0.750	3.00	0.100	0.325	0.051	3	HC75003-090	HC75003-090A	500084	500198
120°	0.125	1.50	0.040	0.025	0.012	3	HC12503-120	HC12503-120A	500091	500204
120°	0.187	2.00	0.050	0.040	0.015	3	HC18703-120	HC18703-120A	500094	500207
120°	0.250	2.50	0.060	0.055	0.018	3	HC25003-120	HC25003-120A	500098	500210
120°	0.375	2.50	0.070	0.088	0.021	3	HC37503-120	HC37503-120A	500105	500216
120°	0.500	3.00	0.080	0.121	0.024	3	HC50003-120	HC50003-120A	500111	500222
120°	0.625	3.00	0.090	0.154	0.027	3	HC62503-120	HC62503-120A	500118	500228
120°	0.750	3.00	0.100	0.188	0.029	3	HC75003-120	HC75003-120A	500125	500234

5 FLUTES FOR HARDER MATERIALS

INCL. ANGLE	"S" SHANK DIA.	OAL	"A" TIP DIA.	"B" LENGTH OF CUT	"C" * REF.	FLUTES	ORDER #		EDP #	
							UNCOATED	ALTiN+	UNCOATED	ALTiN+
60°	0.250	2.50	0.060	0.165	0.054	5	HC25005-060	HC25005-060A	500020	500141
60°	0.375	2.50	0.070	0.264	0.062	5	HC37505-060	HC37505-060A	500026	500147
60°	0.500	3.00	0.080	0.364	0.071	5	HC50005-060	HC50005-060A	500033	500153
60°	0.625	3.00	0.090	0.463	0.080	5	HC62505-060	HC62505-060A	500040	500159
60°	0.750	3.00	0.100	0.563	0.088	5	HC75005-060	HC75005-060A	500047	500165
90°	0.250	2.50	0.060	0.095	0.031	5	HC25005-090	HC25005-090A	500060	500177
90°	0.375	2.50	0.070	0.153	0.036	5	HC37505-090	HC37505-090A	500067	500183
90°	0.500	3.00	0.080	0.210	0.041	5	HC50005-090	HC50005-090A	500074	500189
90°	0.625	3.00	0.090	0.268	0.046	5	HC62505-090	HC62505-090A	500081	500195
90°	0.750	3.00	0.100	0.325	0.051	5	HC75005-090	HC75005-090A	500088	500201
120°	0.250	2.50	0.060	0.055	0.018	5	HC25005-120	HC25005-120A	500101	500213
120°	0.375	2.50	0.070	0.088	0.021	5	HC37505-120	HC37505-120A	500108	500219
120°	0.500	3.00	0.080	0.121	0.024	5	HC50005-120	HC50005-120A	500115	500225
120°	0.625	3.00	0.090	0.154	0.027	5	HC62505-120	HC62505-120A	500122	500231
120°	0.750	3.00	0.100	0.188	0.029	5	HC75005-120	HC75005-120A	500128	500237

[Go to Specialty End Mills Overview](#)

CORNER ROUNDING END MILLS - SOLID CARBIDE

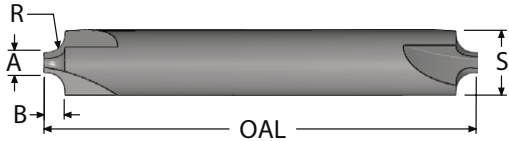

- Tool diameter (A) and the cut depth (B) are held to ± 0.001 inch tolerance to provide ease of set-up
- ALTiN+ coating for higher cutting speed
- Precision ground for maximum concentricity

"R" RADIUS SIZE	"S" SHANK DIA.	OAL	"A" TOOL DIA.	"B" CUT DEPTH	FLUTES	ORDER #		EDP #	
						UNCOATED	ALTiN+	UNCOATED	ALTiN+
0.005	0.125	1.50	0.080	0.020	3	CR125005	CR125005A	500500	500593
0.008	0.125	1.50	0.080	0.023	3	CR125008	CR125008A	500503	500596
0.010	0.125	1.50	0.080	0.025	3	CR125010	CR125010A	500506	500599
0.015	0.125	1.50	0.080	0.030	3	CR125015	CR125015A	500509	500602
0.010	0.1875	2.00	0.120	0.025	3	CR187010	CR187010A	500512	500605
0.015	0.1875	2.00	0.120	0.030	3	CR187015	CR187015A	500515	500608
0.020	0.1875	2.00	0.100	0.035	3	CR187020	CR187020A	500518	500611
0.031	0.1875	2.00	0.100	0.046	3	CR187031	CR187031A	500521	500614
0.010	0.250	2.50	0.170	0.025	3	CR250010	CR250010A	500524	500617
0.015	0.250	2.50	0.170	0.030	3	CR250015	CR250015A	500527	500620
0.020	0.250	2.50	0.170	0.035	3	CR250020	CR250020A	500530	500623
0.025	0.250	2.50	0.170	0.040	3	CR250025	CR250025A	500533	500626
0.031	0.250	2.50	0.140	0.046	3	CR250031	CR250031A	500536	500629
0.035	0.250	2.50	0.140	0.050	3	CR250035	CR250035A	500539	500632
0.040	0.250	2.50	0.140	0.055	3	CR250040	CR250040A	500542	500635
0.046	0.250	2.50	0.140	0.061	3	CR250046	CR250046A	500545	500638
0.050	0.250	2.50	0.100	0.065	3	CR250050	CR250050A	500548	500641
0.055	0.250	2.50	0.100	0.070	3	CR250055	CR250055A	500551	500644
0.062	0.250	2.50	0.100	0.077	3	CR250062	CR250062A	500554	500647
0.072	0.250	2.50	0.100	0.087	3	CR250072	CR250072A	500557	500650
0.078	0.375	2.50	0.150	0.098	3	CR375078	CR375078A	500560	500653
0.085	0.375	2.50	0.150	0.105	3	CR375085	CR375085A	500563	500656
0.094	0.375	2.50	0.150	0.114	3	CR375094	CR375094A	500566	500659
0.100	0.375	2.50	0.120	0.120	3	CR375100	CR375100A	500569	500662
0.110	0.375	2.50	0.120	0.130	3	CR375110	CR375110A	500572	500665
0.118	0.375	2.50	0.100	0.138	3	CR375118	CR375118A	500575	500668
0.125	0.375	2.50	0.100	0.145	3	CR375125	CR375125A	500578	500671
0.140	0.500	3.00	0.150	0.10	3	CR500140	CR500140A	500581	500674
0.156	0.500	3.00	0.150	0.176	3	CR500156	CR500156A	500584	500677
0.172	0.500	3.00	0.100	0.192	3	CR500172	CR500172A	500587	500680
0.187	0.500	3.00	0.100	0.207	3	CR500187	CR500187A	500590	500683

[Go to Specialty End Mills Overview](#)

ENGRAVING TOOLS - SOLID CARBIDE

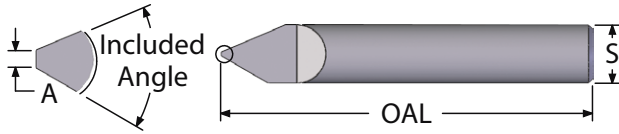

- The tool tip (A) is held to ± 0.001 inch tolerance
- ALTiN+ coating extends tool life
- Made with premium submicron carbide

INCLUDED ANGLE	"S" SHANK DIA.	OAL	"A" TIP DIA.	ORDER #		EDP #	
				UNCOATED	ALTiN+	UNCOATED	ALTiN+
30°	0.1250	1.50	0.005	EN125-30	EN125-30A	500804	500894
30°	0.1875	2.00	0.007	EN187-30	EN187-30A	500819	500909
30°	0.2500	2.50	0.009	EN250-30	EN250-30A	500834	500924
30°	0.3125	2.50	0.011	EN312-30	EN312-30A	500849	500939
30°	0.3750	2.50	0.013	EN375-30	EN375-30A	500864	500954
30°	0.5000	3.00	0.015	EN500-30	EN500-30A	500879	500969
40°	0.1250	1.50	0.005	EN125-40	EN125-40A	500807	500897
40°	0.1875	2.00	0.007	EN187-40	EN187-40A	500822	500912
40°	0.2500	2.50	0.009	EN250-40	EN250-40A	500837	500927
40°	0.3125	2.50	0.011	EN312-40	EN312-40A	500852	500942
40°	0.3750	2.50	0.013	EN375-40	EN375-40A	500867	500957
40°	0.5000	3.00	0.015	EN500-40	EN500-40A	500882	500972
60°	0.1250	1.50	0.005	EN125-60	EN125-60A	500810	500900
60°	0.1875	2.00	0.007	EN187-60	EN187-60A	500825	500915
60°	0.2500	2.50	0.009	EN250-60	EN250-60A	500840	500930
60°	0.3125	2.50	0.011	EN312-60	EN312-60A	500855	500945
60°	0.3750	2.50	0.013	EN375-60	EN375-60A	500870	500960
60°	0.5000	3.00	0.015	EN500-60	EN500-60A	500885	500975
90°	0.1250	1.50	0.005	EN125-90	EN125-90A	500813	500903
90°	0.1875	2.00	0.007	EN187-90	EN187-90A	500828	500918
90°	0.2500	2.50	0.009	EN250-90	EN250-90A	500843	500933
90°	0.3125	2.50	0.011	EN312-90	EN312-90A	500858	500948
90°	0.3750	2.50	0.013	EN375-90	EN375-90A	500873	500963
90°	0.5000	3.00	0.015	EN500-90	EN500-90A	500888	500978
120°	0.1250	1.50	0.005	EN125-120	EN125-120A	500801	500891
120°	0.1875	2.00	0.007	EN187-120	EN187-120A	500816	500906
120°	0.2500	2.50	0.009	EN250-120	EN250-120A	500831	500921
120°	0.3125	2.50	0.011	EN312-120	EN312-120A	500846	500936
120°	0.3750	2.50	0.013	EN375-120	EN375-120A	500861	500951
120°	0.5000	3.00	0.015	EN500-120	EN500-120A	500876	500966

New Product:
Spotting Drills

Click to go to Spotting Drills Page



[Go to Specialty End Mills Overview](#)

SPECIALTY TOOL - HELICAL CHAMFER MILL

TECHNICAL INFORMATION

MATERIAL	ROCKWELL HARDNESS	SPEED (SFM) UNCOATED	SPEED (SFM) AITiN+	FEED (Inches per tooth)							
				CALCULATED CUTTING DIAMETER							
				<.125	.125-.1875	.1875-.250	.250-.3125	.3125-.375	.375-.500	.500-.625	.625-.750
Gray Cast Iron	85Rb	250	450	0.0012	0.0022	0.0035	0.0045	0.0050	0.0055	0.0070	0.0090
Ductile Cast Iron	85Rb	180	375	0.0007	0.0015	0.0020	0.0028	0.0035	0.0040	0.0055	0.0070
Carbon Steel	18Rc	225	450	0.0007	0.0015	0.0022	0.0028	0.0035	0.0045	0.0055	0.0070
Alloy Steel	20Rc	200	400	0.0006	0.0012	0.0020	0.0025	0.0030	0.0040	0.0050	0.0060
Heat Treated Alloys	40Rc	100	200	0.0003	0.0007	0.0010	0.0012	0.0018	0.0020	0.0028	0.0035
Tool Steel	20Rc	150	325	0.0006	0.0010	0.0018	0.0022	0.0028	0.0035	0.0045	0.0055
300 Stainless Steel	80Rb	120	250	0.0005	0.0009	0.0015	0.0018	0.0022	0.0028	0.0035	0.0045
400 Stainless Steel	95Rb	140	325	0.0004	0.0009	0.0012	0.0018	0.0022	0.0025	0.0035	0.0045
Nickel Alloy	20Rc	120	175	0.0005	0.0009	0.0012	0.0018	0.0022	0.0028	0.0035	0.0045
Cobalt Alloy	20Rc	140	225	0.0003	0.0006	0.0009	0.0012	0.0015	0.0018	0.0022	0.0030
Titanium	25Rc	160	250	0.0005	0.0009	0.0012	0.0018	0.0022	0.0028	0.0035	0.0045
Aluminum	60Rb	1000	1900	0.0010	0.0028	0.0040	0.0055	0.0070	0.0080	0.0110	0.0130
Brass, Zinc, Copper	41Rb	320	600	0.0008	0.0015	0.0022	0.0030	0.0040	0.0045	0.0060	0.0080

Determining the Calculated Cutting Diameter

Surface footage and chip load should be calculated at the "Calculated Cutting Diameter" or CCD. The CCD is the largest diameter of the tool that engages the part.

$$\text{Calculated Cutting Diameter} = 2 \times \text{Depth} \times \tan(\text{Included Angle} / 2) + \text{Tip Diameter}$$

$$\text{CCD} = 2 \times Z \times \tan(I/2) + A$$

Choose a "Z - Depth" based on the "B - Length of Cut" of the selected tool. This should result in the part only contacting the included angle of the tool. The part should never touch the shank or tip of the tool. Using a Z - Depth that results in a larger CCD (closer to the shank) is preferred over a smaller CCD (closer to the tip). Find tool dimensions in chart on the product page.

RPM and IPM should be calculated using the Calculated Cutting Diameter.

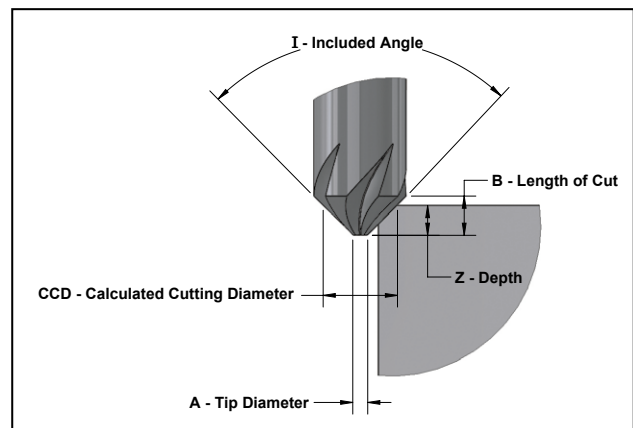

Example:

Tool: HC50003-090A

I - Included Angle: 90°

A - Tip Diameter: 0.080"

B - Length of Cut: 0.210"

Chosen Z - Depth: 0.200"

Calculation:

$$\text{CCD} = 2 \times Z \times \tan(I/2) + A$$

$$\text{CCD} = 2 \times 0.200" \times \tan(90^\circ/2) + 0.080"$$

$$\text{CCD} = 0.480"$$

SPECIALTY TOOL - CORNER ROUNDING END MILL FEED AND SPEED CHART

MATERIAL	ROCKWELL HARDNESS	SPEED (SFM) UNCOATED	SPEED (SFM) AITiN+	FEED (Inches per tooth)				
				Tool Size				
				CR125	CR187	CR250	CR375	CR500
Cast Iron	85Rb	200	350	0.0004	0.0005	0.0009	0.0015	0.0017
Carbon Steel	18Rc	200	400	0.0004	0.0005	0.0008	0.0013	0.0015
Alloy Steel	20Rc	160	330	0.0003	0.0004	0.0007	0.0012	0.0014
Heat Treated Alloys (38-45Rc)	40Rc	60	100	0.0002	0.0003	0.0004	0.0007	0.0009
Tool Steel	20Rc	125	150	0.0002	0.0003	0.0004	0.0007	0.0009
Stainless Steel	95Rb	120	250	0.0003	0.0004	0.0007	0.0012	0.0014
Titanium	25Rc	110	150	0.0002	0.0003	0.0004	0.0007	0.0009
Aluminum	60Rb	450	750	0.0008	0.0011	0.0017	0.0028	0.0033
Brass, Zinc,	41Rb	300	500	0.0007	0.0010	0.0015	0.0025	0.0030

SPECIALTY TOOL - ENGRAVING TOOL FEED AND SPEED CHART

MATERIAL	RPM	FEED (Inches per tooth)									
		INCLUDED ANGLE									
		30°		40°		60°		90°		120°	
		SHANK DIAMETER									
		.125-.187	.250-.500	.125-.187	.250-.500	.125-.187	.250-.500	.125-.187	.250-.500	.125-.187	.250-.500
Cast Iron	6000+	0.0011	0.0014	0.0012	0.0016	0.0016	0.0020	0.0017	0.0022	0.0019	0.0024
Carbon Steel	6000+	0.0006	0.0008	0.0007	0.0009	0.0009	0.0012	0.0010	0.0013	0.0011	0.0014
Alloy Steel	6000+	0.0005	0.0006	0.0005	0.0007	0.0007	0.0009	0.0007	0.0009	0.0008	0.0010
Heat Treated Alloys	6000+	0.0002	0.0003	0.0003	0.0004	0.0004	0.0005	0.0004	0.0005	0.0004	0.0006
Tool Steel	6000+	0.0004	0.0005	0.0005	0.0006	0.0006	0.0008	0.0007	0.0008	0.0007	0.0009
Stainless Steel	6000+	0.0005	0.0007	0.0006	0.0008	0.0008	0.0010	0.0008	0.0011	0.0009	0.0012
Titanium	6000+	0.0005	0.0007	0.0006	0.0008	0.0008	0.0010	0.0008	0.0011	0.0009	0.0012
Aluminum	6000+	0.0011	0.0014	0.0012	0.0016	0.0016	0.0020	0.0017	0.0022	0.0019	0.0024
Plastics	6000+	0.0016	0.0021	0.0019	0.0024	0.0024	0.0030	0.0026	0.0033	0.0028	0.0036

Suggested chip loads reflect engraving depths up to .010". For depths of cut between .010"-.015", reduce suggested chip loads by 20%. For depths of cut between .015"-.020", reduce suggested chip load by 30%.

Ramping into the part is preferred but if plunge milling into the part, reduce suggested chip load by 50%.

MORE FROM SCT: CUSTOM & MODIFIED TOOLS

MODIFICATIONS ON MANY STANDARD TOOLS

Scientific Cutting Tools can modify many standard tools with fast turn around: most items within 5 working days. Modifications can help specific cutting needs for better function such as decreased tool pressure, helping prevent potential breakage, accessibility issues such as length or depth of cut.

[Click here to request a quote](#)

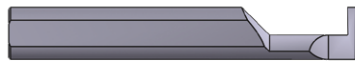
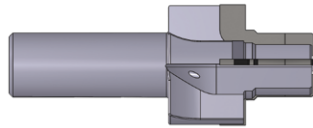

THREAD MILLS MODIFIED

- Reduce length-of-cut to increase strength
- Resharpen and recoat thread mills (**2-3 weeks**)
- Neck back thread mills for greater depth of cut

PORT TOOLS MODIFIED

- Reduce spot face diameter
- Reduce length of minor thread diameter
- Shorten reamer or cut off solid pilot

SINGLE POINT MODIFIED

- Lengthen tool reach on groove tools or boring bars
- Add chip curls to boring bars
- Modify cutting depth or width on groove tools

CUSTOM TOOLING FOR SPECIFIC FEATURES AND PROJECTS

Scientific Cutting Tools applies the same caliber of craftsmanship and quality on customs as their standard tools. Highly knowledgeable and experienced engineers can assist with designs to create a precision custom tool for any job. Sub-micron carbide and special coating options are available. SCT has over fifty years of experience in the cutting tool industry to transform designs into valuable tools.

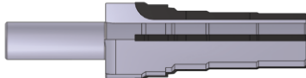
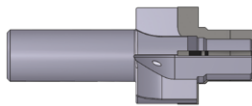

THREAD MILLS

Special Thread Forms	Locking Threads
ACME	Serration Tools
Stub ACME	Buttress
Tapered double lead	Custom Tools to Print

PORT TOOLS

Autoclave	High Performance
Cavity	Coolant Through
Multi-step Port Tools	Custom Tools to Print

SINGLE POINT

Special Threading Tools for Bone Screws and Plates
Special Forms
Modified Groove Specials
Face Grooving
Buttress
ACME & Stub ACME
Custom Tools to Print

Please contact our engineering department for more information: (805) 584-9495

Connect with Scientific Cutting Tools



www.sct-usa.com



sales@sct-usa.com



Subscribe to our channel



Scientific Cutting Tools, Inc.



SCTcuttingtools



Scientific Cutting Tools

**Complimentary technical assistance during business hours.
Call 800-383-2244 or 805-584-9495.**

Visit www.sct-usa.com to learn more about SCT products.

**Version
4.19**



SCIENTIFIC CUTTING TOOLS, INC.

805.584.9495 FAX 805.584.9629

800.383.2244 FAX 800.728.3295

www.sct-usa.com
sales@sct-usa.com

The SCT Guarantee
Our pride in workmanship
assures product quality
every time

CLICK TO LEARN HOW TO USE THE INTERACTIVE CATALOG

CLICK TO REQUEST A PRINTED COPY

CLICK TO GO TO TABLE OF CONTENTS

CLICK TO VIEW BOOKMARK NAVIGATION PANEL

CLICK TO SEARCH THIS CATALOG

PCD
QUALIFIED
CARRIDE
CAVITY TOOLS
PORT TOOLS
GROOVE TO
SPECIALTY
INDEXABLE BORING
BORING BARS
LONG REA
THREAD MILLS
HELICAL
ALTiN+
METRIC
CBN
STUB ACME

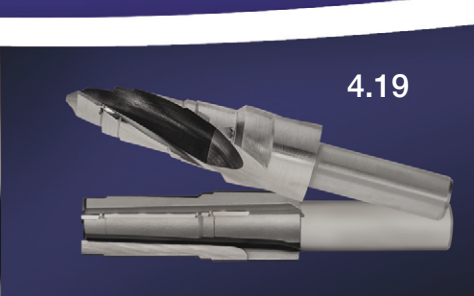
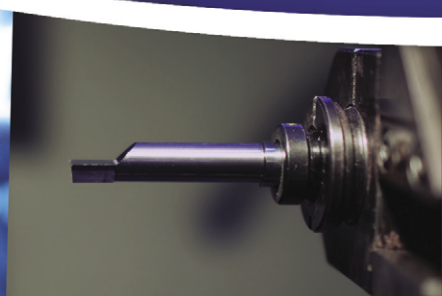

How to Use the Interactive Catalog

The Scientific Cutting Tools interactive product catalog was designed with you in mind. It has hundreds of interactive features and shortcuts to help you navigation efficiently. Simply click with a mouse on a standard computer or tap/touch if on a electronic touch screen device.

Navigating Bookmarks

Blue bookmarks take you to the appropriate web location.

Example: Where to buy our products. News and Blog.

Red Bookmarks performs special functions like prepare an email to be sent to our engineering or sales department, open up a search.

Example: Email Contacts. Search this Catalog

Black Bookmarks take you to specific locations within the catalog like the table of contents or a product section.

Please take a moment and explore all of the bookmarks. Feedback is always welcomed

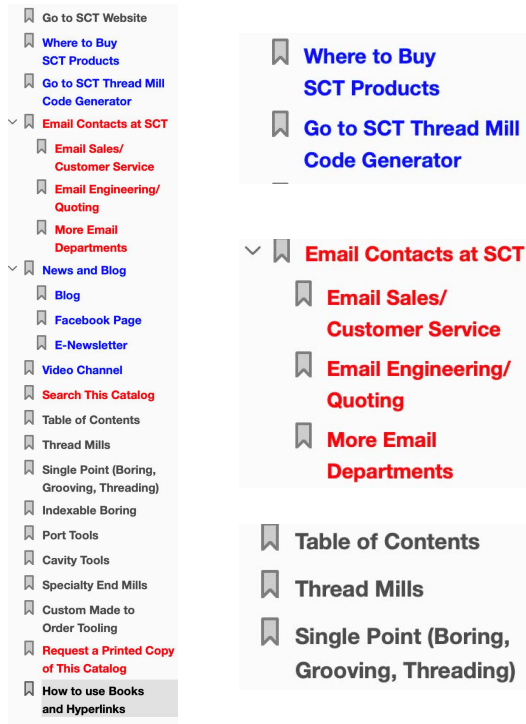

Move Around with Hyperlinks

Hyperlinks are just *shortcuts to move around the catalog*. For example, navigate to the table of contents. **Simply take your cursor and click on the page numbers, and it will take you immediately to those pages.** The section tabs will jump you from section to section. There are hundreds of hyperlinks throughout this interactive catalog.

On the products overview pages simply click on the product you want to go to it, it will jump to the appropriate pages.

Please take a moment and explore all of the hyperlinks and bookmarks. Feedback is always welcomed

SINGLE POINT TOOLS.....	33-72
HOLDERS.....	35-37
BORING BARS.....	38-54
GROOVING TOOLS.....	55-61
THREADING TOOLS.....	62-66
TECHNICAL INFORMATION.....	67-72



Mini Boring Bars (p.38)
Mini Boring Bars range in diameter from 0.015 to 0.045 inch. They are fluted for maximum strength.

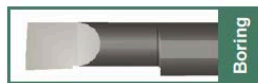

Radial Relief (p.39)
Radial Relief Boring Bars have a radial relief behind the cutting edge that provides for a strong cutting edge.

SPOTTING DRILLS - SOLID CARBIDE

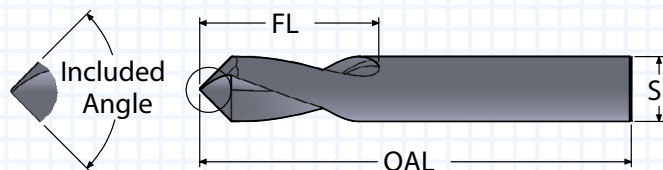

- Designed with a 4-facet point and constant web
- Point angle is held to $\pm 1^\circ$ tolerance
- 20° helical flute
- ALTiN+ coating extends tool life

INCLUDED ANGLE	"S" SHANK DIA.	OAL	"FL" FLUTE LENGTH	FLUTES	ORDER #		EDP #	
					UNCOATED	ALTiN+	UNCOATED	ALTiN+
82°	0.1250	2.00	0.40	2	SPD125-082	SPD125-082A	501000	501080
82°	0.1875	2.00	0.50	2	SPD187-082	SPD187-082A	501010	501090
82°	0.2500	2.50	0.70	2	SPD250-082	SPD250-082A	501020	501100
82°	0.3125	2.50	0.90	2	SPD312-082	SPD312-082A	501030	501110
82°	0.3750	3.00	1.00	2	SPD375-082	SPD375-082A	501040	501120
82°	0.5000	3.00	1.10	2	SPD500-082	SPD500-082A	501050	501130
82°	0.6250	3.50	1.20	2	SPD625-082	SPD625-082A	501060	501140
82°	0.7500	4.00	1.30	2	SPD750-082	SPD750-082A	501070	501150
90°	0.1250	2.00	0.40	2	SPD125-090	SPD125-090A	501002	501082
90°	0.1875	2.00	0.50	2	SPD187-090	SPD187-090A	501012	501092
90°	0.2500	2.50	0.70	2	SPD250-090	SPD250-090A	501022	501102
90°	0.3125	2.50	0.90	2	SPD312-090	SPD312-090A	501032	501112
90°	0.3750	3.00	1.00	2	SPD375-090	SPD375-090A	501042	501122
90°	0.5000	3.00	1.10	2	SPD500-090	SPD500-090A	501052	501132
90°	0.6250	3.50	1.20	2	SPD625-090	SPD625-090A	501062	501142
90°	0.7500	4.00	1.30	2	SPD750-090	SPD750-090A	501072	501152
100°	0.1250	2.00	0.40	2	SPD125-100	SPD125-100A	501004	501084
100°	0.1875	2.00	0.50	2	SPD187-100	SPD187-100A	501014	501094
100°	0.2500	2.50	0.70	2	SPD250-100	SPD250-100A	501024	501104
100°	0.3125	2.50	0.90	2	SPD312-100	SPD312-100A	501034	501114
100°	0.3750	3.00	1.00	2	SPD375-100	SPD375-100A	501044	501124
100°	0.5000	3.00	1.10	2	SPD500-100	SPD500-100A	501054	501134
100°	0.6250	3.50	1.20	2	SPD625-100	SPD625-100A	501064	501144
100°	0.7500	4.00	1.30	2	SPD750-100	SPD750-100A	501074	501154
120°	0.1250	2.00	0.40	2	SPD125-120	SPD125-120A	501006	501086
120°	0.1875	2.00	0.50	2	SPD187-120	SPD187-120A	501016	501096
120°	0.2500	2.50	0.70	2	SPD250-120	SPD250-120A	501026	501106
120°	0.3125	2.50	0.90	2	SPD312-120	SPD312-120A	501036	501116
120°	0.3750	3.00	1.00	2	SPD375-120	SPD375-120A	501046	501126
120°	0.5000	3.00	1.10	2	SPD500-120	SPD500-120A	501056	501136
120°	0.6250	3.50	1.20	2	SPD625-120	SPD625-120A	501066	501146
120°	0.7500	4.00	1.30	2	SPD750-120	SPD750-120A	501076	501156
142°	0.1250	2.00	0.40	2	SPD125-142	SPD125-142A	501008	501088
142°	0.1875	2.00	0.50	2	SPD187-142	SPD187-142A	501018	501098
142°	0.2500	2.50	0.70	2	SPD250-142	SPD250-142A	501028	501108
142°	0.3125	2.50	0.90	2	SPD312-142	SPD312-142A	501038	501118
142°	0.3750	3.00	1.00	2	SPD375-142	SPD375-142A	501048	501128
142°	0.5000	3.00	1.10	2	SPD500-142	SPD500-142A	501058	501138
142°	0.6250	3.50	1.20	2	SPD625-142	SPD625-142A	501068	501148
142°	0.7500	4.00	1.30	2	SPD750-142	SPD750-142A	501078	501158

For optimal performance choose a spotting drill angle that is equal or greater than the angle of the following drill

[Go to Specialty End Mills Overview](#)

DRILL MILLS - SOLID CARBIDE

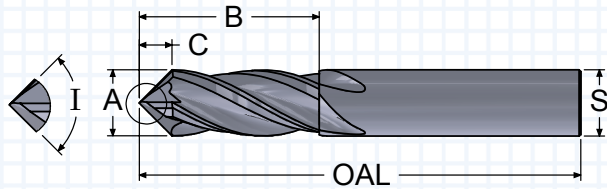

- For milling, chamfering and light spotting applications
- ALTiN+ coating for higher cutting speed
- Precision ground for maximum concentricity

"I" INCLUDED ANGLE	"A" TOOL DIA.	"B" LENGTH OF CUT	"C" TIP LENGTH	"S" SHANK DIA.	OAL	FLUTES	ORDER #		EDP #	
							UNCOATED	ALTiN+	UNCOATED	ALTiN+
90°	0.125	0.500	0.061	0.125	1.50	2	DRM125-02-090	DRM125-02-090A	502000	502002
90°	0.125	0.500	0.061	0.125	1.50	4	DRM125-04-090	DRM125-04-090A	502008	502010
90°	0.1875	0.625	0.092	0.1875	2.00	2	DRM187-02-090	DRM187-02-090A	502016	502018
90°	0.1875	0.625	0.092	0.1875	2.00	4	DRM187-04-090	DRM187-04-090A	502024	502026
90°	0.250	0.750	0.123	0.250	2.50	2	DRM250-02-090	DRM250-02-090A	502032	502034
90°	0.250	0.750	0.123	0.250	2.50	4	DRM250-04-090	DRM250-04-090A	502040	502042
90°	0.3125	0.812	0.155	0.3125	2.50	2	DRM312-02-090	DRM312-02-090A	502048	502050
90°	0.3125	0.812	0.155	0.3125	2.50	4	DRM312-04-090	DRM312-04-090A	502056	502058
90°	0.375	1.000	0.186	0.375	2.50	2	DRM375-02-090	DRM375-02-090A	502064	502066
90°	0.375	1.000	0.186	0.375	2.50	4	DRM375-04-090	DRM375-04-090A	502072	502074
90°	0.500	1.000	0.248	0.500	3.00	2	DRM500-02-090	DRM500-02-090A	502080	502082
90°	0.500	0.100	0.248	0.500	3.00	4	DRM500-04-090	DRM500-04-090A	502088	502090
120°	0.125	0.500	0.035	0.125	1.50	2	DRM125-02-120	DRM125-02-120A	502004	502006
120°	0.125	0.500	0.035	0.125	1.50	4	DRM125-04-120	DRM125-04-120A	502012	502014
120°	0.1875	0.625	0.053	0.1875	2.00	2	DRM187-02-120	DRM187-02-120A	502020	502022
120°	0.1875	0.625	0.053	0.1875	2.00	4	DRM187-04-120	DRM187-04-120A	502028	502030
120°	0.250	0.750	0.071	0.250	2.50	2	DRM250-02-120	DRM250-02-120A	502036	502038
120°	0.250	0.750	0.071	0.250	2.50	4	DRM250-04-120	DRM250-04-120A	502044	502046
120°	0.3125	0.812	0.089	0.3125	2.50	2	DRM312-02-120	DRM312-02-120A	502052	502054
120°	0.3125	0.812	0.089	0.3125	2.50	4	DRM312-04-120	DRM312-04-120A	502060	502062
120°	0.375	1.000	0.107	0.375	2.50	2	DRM375-02-120	DRM375-02-120A	502068	502070
120°	0.375	1.000	0.107	0.375	2.50	4	DRM375-04-120	DRM375-04-120A	502076	502078
120°	0.500	1.000	0.143	0.500	3.00	2	DRM500-02-120	DRM500-02-120A	502084	502086
120°	0.500	0.100	0.143	0.500	3.00	4	DRM500-04-120	DRM500-04-120A	502092	502094

[Go to Specialty End Mills Overview](#)

THREAD MILLS

SINGLE POINT

INDEXABLE TOOLS

PORT - CAVITY

SPECIALTY END MILLS
DRILL MILL

ISO 1179 - PORT TOOL CARBIDE TIPPED

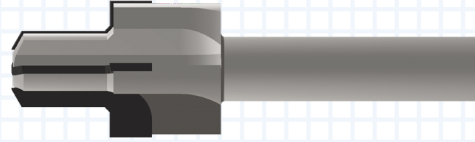
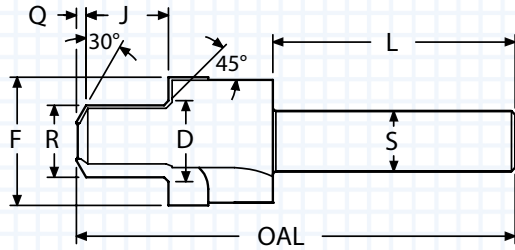

- Meets the requirements of the ISO1179
- Polished flute face for optimum performance
- Precision ground for maximum concentricity
- AlTiN+ coating for improved surface finish

D	F	J	R	Q	L	S	OAL	FLUTES	THREAD	ORDER #		EDP #	
										UNCOATED	ALTiN+	UNCOATED	ALTiN+
0.398	0.681	0.445	0.345	0.045	2.00	0.500	3.50	3	G1/8	1179-G125	1179-G125A	402874	402875
0.524	0.819	0.683	0.459	0.065	2.00	0.500	3.62	3	G1/4	1179-G250	1179-G250A	402876	402877
0.662	0.969	0.683	0.597	0.080	2.00	0.500	3.62	4	G3/8	1179-G375	1179-G375A	402878	402879
0.831	1.169	0.801	0.741	0.090	2.00	0.750	3.62	4	G1/2	1179-G500	1179-G500A	402880	402881
1.048	1.457	0.880	0.958	0.120	2.50	0.750	4.37	4	G3/4	1179-G750	1179-G750A	402882	402883
1.319	1.819	0.998	1.201	0.120	2.50	1.000	4.62	4	G1	1179-G1000	1179-G1000A	402884	402885
1.662	2.130	1.078	1.541	0.125	2.50	1.000	4.62	4	G1-1/4	1179-G1250	1179-G1250A	402886	402887
1.894	2.386	1.200	1.774	0.125	2.50	1.000	4.88	4	G1-1/2	1179-G1500	1179-G1500A	402888	402889

[Go to Port Tools Overview](#)

AUTOCLAVE PORT TOOLS - MEDIUM PRESSURE SOLID CARBIDE AND CARBIDE-TIPPED

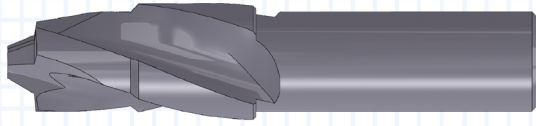

- Designed to produce ports per Parker Autoclave Standard
- Precision ground for maximum concentricity
- Polished flute face for optimum performance
- AlTiN+ coating for improved tool life

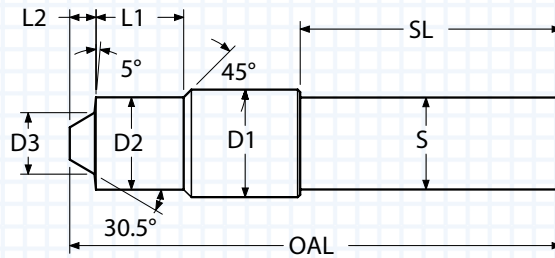

D1	D2	D3	L1	L2	S	SL	OAL	FLUTES	FLUTE TYPE	TUBE	THREAD	CONNECTION TYPE	ORDER #	EDP #
													AlTiN+	AlTiN+
Solid Carbide														
0.500	0.390	0.188	0.471	0.101	0.500	2.13	3.50	3	Helical	1/4	7/16-20	SF250CX	PT-SF0250CX-A	405006
0.625	0.511	0.310	0.599	0.134	0.500	2.13	3.50	3	Helical	3/8	9/16-18	SF375CX	PT-SF0375CX-A	405008
0.875	0.752	0.500	0.715	0.213	0.750	2.13	4.00	3	Helical	9/16	13/16-16	SF562CX10 SF562CX20	PT-SF0562CX-A	405010
Carbide-Tipped														
1.090	0.966	0.625	0.899	0.216	0.750	2.25	4.50	3	Straight	3/4	3/4-14 NPS	SF750CX10 SF750CX20	PT-SF0750CX-A	405012
1.438	1.297	0.875	1.266	0.418	0.750	2.25	4.75	3	Straight	1	1-3/8-12	SF1000CX10 SF1000CX20	PT-SF1000CX-A	405014

THREAD MILLS

SINGLE POINT

INDEXABLE TOOLS

Port Tools

SPECIALTY

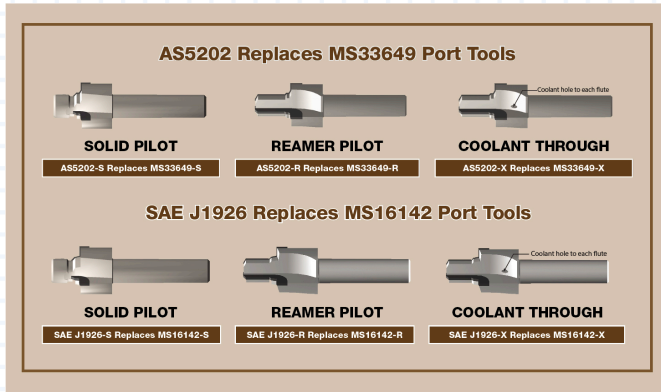

Click to view the crossover chart for MS16142 to SAE J1926

SAE J1926 (MS16142) O-RING BOSS PORT TOOL SOLID PILOT - CARBIDE TIPPED

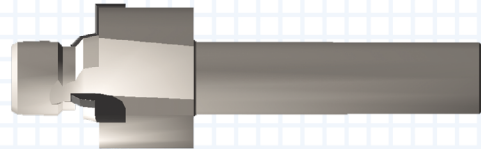
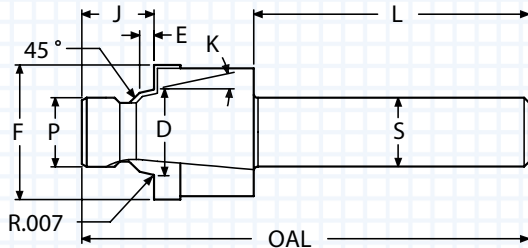

- Ideal for non-standard minor diameter lengths
- Often called ORB (followed by port size number)
- Meets the requirements of SAEJ1926/1
- Polished flute face for optimum performance
- ALTiN+ coating for improved surface finish
- Meets the requirements of MS16142

K	D	E	F	P	J	L	S	OAL	FLUTES	TUBE	THREAD	SAE#	ORDER #		EDP #	
													UNCOATED	ALTiN+	UNCOATED	ALTiN+
12°	0.3605	0.082	0.682	0.270	0.365	2.00	0.500	3.00	3	0.125	0.3125-24 UNF-2B	SAE#2	SAEJ1926-02S	SAEJ1926-02SA	406301	406303
12°	0.4235	0.082	0.760	0.331	0.415	2.00	0.500	3.00	3	0.188	0.3750-24 UNF-2B	SAE#3	SAEJ1926-03S	SAEJ1926-03SA	406305	406307
12°	0.4895	0.101	0.838	0.385	0.445	2.00	0.500	3.12	3	0.250	0.4375-20 UNF-2B	SAE#4	SAEJ1926-04S	SAEJ1926-04SA	406309	406311
12°	0.5525	0.101	0.916	0.448	0.465	2.00	0.500	3.12	3	0.312	0.5000-20 UNF-2B	SAE#5	SAEJ1926-05S	SAEJ1926-05SA	406313	406315
12°	0.6185	0.105	0.990	0.504	0.495	2.00	0.500	3.25	3	0.375	0.5625-18 UNF-2B	SAE#6	SAEJ1926-06S	SAEJ1926-06SA	406317	406319
15°	0.8135	0.108	1.198	0.685	0.560	2.12	0.750	3.57	3	0.500	0.7500-16 UNF-2B	SAE#8	SAEJ1926-08S	SAEJ1926-08SA	406321	406323
15°	0.9445	0.108	1.354	0.801	0.610	2.12	0.750	3.66	3	0.625	0.8750-14 UNF-2B	SAE#10	SAEJ1926-10S	SAEJ1926-10SA	406325	406327
15°	1.1505	0.138	1.635	0.975	0.640	2.12	0.750	3.75	3	0.750	1.0625-12 UN-2B	SAE#12	SAEJ1926-12S	SAEJ1926-12SA	406329	406331
15°	1.2755	0.138	1.775	1.101	0.710	2.25	1.000	4.00	3	0.875	1.1875-12 UN-2B	SAE#14	SAEJ1926-14S	SAEJ1926-14SA	406333	406335
15°	1.4005	0.138	1.935	1.225	0.710	2.25	1.000	4.05	3	1.000	1.3125-12 UN-2B	SAE#16	SAEJ1926-16S	SAEJ1926-16SA	406337	406339
15°	1.7155	0.140	2.290	1.537	0.750	2.25	1.000	4.20	3	1.250	1.6250-12 UN-2B	SAE#20	SAEJ1926-20S	SAEJ1926-20SA	406341	406343
15°	1.9645	0.140	2.570	1.787	0.750	2.25	1.000	4.20	3	1.500	1.8750-12 UN-2B	SAE#24	SAEJ1926-24S	SAEJ1926-24SA	406345	406347
15°	2.5895	0.140	3.490	2.412	0.800	2.50	1.250	4.60	3	2.000	2.5000-12 UN-2B	SAE#32	SAEJ1926-32S	SAEJ1926-32SA	406349	406351

Thread mills are available. See pages 8-18.

[Go to Port Tools Overview](#)

SAE J1926 (MS16142) O-RING BOSS PORT TOOL REAMER PILOT - CARBIDE TIPPED

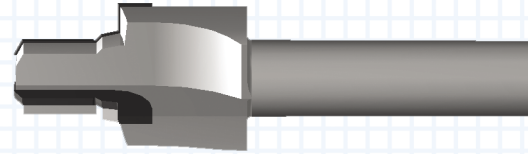
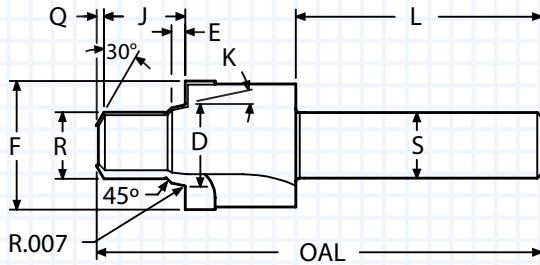

- Reams minor thread diameter to size
- Precision ground for maximum concentricity
- Often called ORB (followed by port size number)
- ALTiN+ coating extends tool life
- Meets the requirements of SAEJ1926/1
- Meets the requirements of MS16142

K	D	E	F	R	J	Q	L	S	OAL	FLUTES	TUBE	THREAD	SAE#	ORDER #		EDP #	
														UNCOATED	ALTiN+	UNCOATED	ALTiN+
12°	0.3605	0.082	0.682	0.271	0.479	0.032	1.75	0.500	3.00	3	0.125	0.3125-24 UNF-2B	SAE#2	SAEJ1926-02R	SAEJ1926-02RA	406001	406003
12°	0.4235	0.082	0.760	0.333	0.479	0.040	1.75	0.500	3.00	3	0.188	0.3750-24 UNF-2B	SAE#3	SAEJ1926-03R	SAEJ1926-03RA	406007	406009
12°	0.4895	0.101	0.838	0.388	0.558	0.045	1.88	0.500	3.12	3	0.250	0.4375-20 UNF-2B	SAE#4	SAEJ1926-04R	SAEJ1926-04RA	406013	406015
12°	0.5525	0.101	0.916	0.450	0.558	0.045	1.88	0.500	3.12	3	0.312	0.5000-20 UNF-2B	SAE#5	SAEJ1926-05R	SAEJ1926-05RA	406019	406021
12°	0.6185	0.105	0.990	0.507	0.620	0.055	1.88	0.500	3.38	3	0.375	0.5625-18 UNF-2B	SAE#6	SAEJ1926-06R	SAEJ1926-06RA	406025	406027
15°	0.8135	0.108	1.198	0.688	0.699	0.070	2.12	0.750	3.70	3	0.500	0.7500-16 UNF-2B	SAE#8	SAEJ1926-08R	SAEJ1926-08RA	406031	406033
15°	0.9445	0.108	1.354	0.804	0.792	0.080	2.12	0.750	3.80	3	0.625	0.8750-14 UNF-2B	SAE#10	SAEJ1926-10R	SAEJ1926-10RA	406037	406039
15°	1.1505	0.138	1.635	0.979	0.917	0.080	2.12	0.750	3.94	3	0.750	1.0625-12 UN-2B	SAE#12	SAEJ1926-12R	SAEJ1926-12RA	406043	406045
15°	1.2755	0.138	1.775	1.104	0.917	0.090	2.25	1.000	4.21	3	0.875	1.1875-12 UN-2B	SAE#14	SAEJ1926-14R	SAEJ1926-14RA	406049	406051
15°	1.4005	0.138	1.935	1.229	0.917	0.090	2.25	1.000	4.25	3	1.000	1.3125-12 UN-2B	SAE#16	SAEJ1926-16R	SAEJ1926-16RA	406055	406057
15°	1.7155	0.140	2.290	1.542	0.917	0.095	2.25	1.000	4.35	3	1.250	1.6250-12 UN-2B	SAE#20	SAEJ1926-20R	SAEJ1926-20RA	406061	406063
15°	1.9645	0.140	2.570	1.792	0.917	0.095	2.25	1.000	4.54	3	1.500	1.8750-12 UN-2B	SAE#24	SAEJ1926-24R	SAEJ1926-24RA	406067	406069
15°	2.5895	0.140	3.490	2.417	0.917	0.095	2.50	1.250	5.15	3	2.000	2.5000-12 UN-2B	SAE#32	SAEJ1926-32R	SAEJ1926-32RA	406073	406075

Thread mills are available. See pages 8-18.

Click to view the crossover chart
for MS16142 to SAE J1926

[Go to Port Tools Overview](#)

SAE J1926 (SAEJ514) O-RING BOSS PORT TOOL REAMER PILOT - CARBIDE TIPPED - COOLANT THROUGH

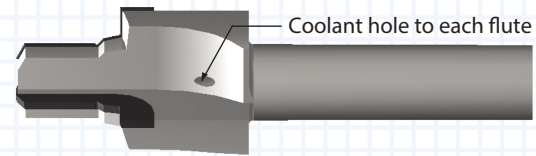
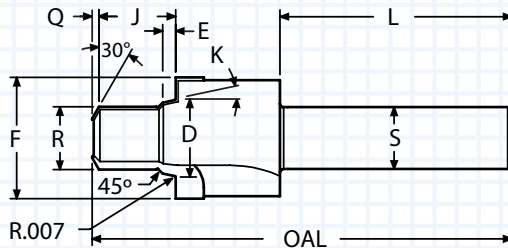

- Reams minor thread diameter to size
- Precision ground for maximum concentricity
- Often called ORB (followed by port size number)
- ALTiN+ coating extends tool life
- Meets the requirements of SAEJ1926/1
- Meets the requirements of MS16142

K	D	E	F	R	J	Q	L	S	OAL	FLUTES	TUBE	THREAD	SAE#	ORDER #			
														UNCOATED	ALTiN+	UNCOATED	ALTiN+
12°	0.3605	0.082	0.682	0.271	0.479	0.032	1.75	0.500	3.00	3	0.125	0.3125-24 UNF-2B	SAE#2	SAEJ1926-02R-X3	SAEJ1926-02R-X3A	406201	406203
12°	0.4235	0.082	0.760	0.333	0.479	0.040	1.75	0.500	3.00	3	0.188	0.3750-24 UNF-2B	SAE#3	SAEJ1926-03R-X3	SAEJ1926-03R-X3A	406205	406207
12°	0.4895	0.101	0.838	0.388	0.558	0.045	1.88	0.500	3.12	3	0.250	0.4375-20 UNF-2B	SAE#4	SAEJ1926-04R-X3	SAEJ1926-04R-X3A	406209	406211
12°	0.5525	0.101	0.916	0.450	0.558	0.045	1.88	0.500	3.12	3	0.312	0.5000-20 UNF-2B	SAE#5	SAEJ1926-05R-X3	SAEJ1926-05R-X3A	406213	406215
12°	0.6185	0.105	0.990	0.507	0.620	0.055	1.88	0.500	3.38	3	0.375	0.5625-18 UNF-2B	SAE#6	SAEJ1926-06R-X3	SAEJ1926-06R-X3A	406217	406219
15°	0.8135	0.108	1.198	0.688	0.699	0.070	2.12	0.750	3.70	3	0.500	0.7500-16 UNF-2B	SAE#8	SAEJ1926-08R-X3	SAEJ1926-08R-X3A	406221	406223
15°	0.9445	0.108	1.354	0.804	0.792	0.080	2.12	0.750	3.80	3	0.625	0.8750-14 UNF-2B	SAE#10	SAEJ1926-10R-X3	SAEJ1926-10R-X3A	406225	406227
15°	1.1505	0.138	1.635	0.979	0.917	0.080	2.12	0.750	3.94	3	0.750	1.0625-12 UN-2B	SAE#12	SAEJ1926-12R-X3	SAEJ1926-12R-X3A	406229	406231
15°	1.2755	0.138	1.775	1.104	0.917	0.090	2.25	1.000	4.21	3	0.875	1.1875-12 UN-2B	SAE#14	SAEJ1926-14R-X3	SAEJ1926-14R-X3A	406233	406235
15°	1.4005	0.138	1.935	1.229	0.917	0.090	2.25	1.000	4.25	3	1.000	1.3125-12 UN-2B	SAE#16	SAEJ1926-16R-X3	SAEJ1926-16R-X3A	406237	406239

Thread mills are available. See pages 8-18.

**Click to view the crossover chart
for MS16142 to SAE J1926**

[Go to Port Tools Overview](#)

AS5202 (MS33649) - PORT TOOL SOLID PILOT - CARBIDE TIPPED

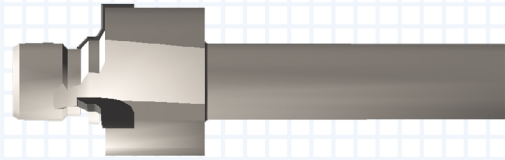
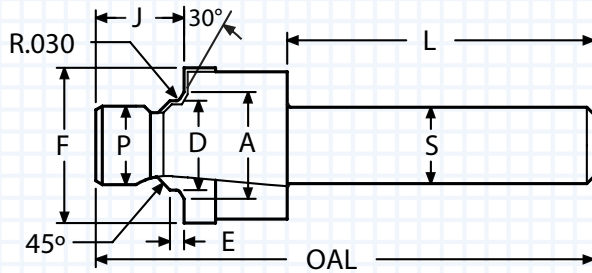

- Ideal for non-standard minor diameter lengths
- Polished flute face for optimum performance
- Meets the requirements of MS33649
- ALTiN+ coating for improved surface finish
- This port requires a UNJ thread which will specify a larger minor thread diameter

A	D	E	F	J	P	L	S	OAL	FLUTES	TUBE	THREAD	ORDER #		EDP #	
												UNCOATED	ALTiN+	UNCOATED	ALTiN+
0.367	0.2665	0.071	0.575	0.345	0.217	2.00	0.500	3.00	3	N/A	0.2500-28 UNJF-3B	AS5202-01S	AS5202-01SA	406701	406703
0.446	0.3305	0.071	0.742	0.365	0.274	2.00	0.500	3.00	3	0.125	0.3125-24 UNJF-3B	AS5202-02S	AS5202-02SA	406705	406707
0.508	0.3925	0.071	0.805	0.415	0.337	2.00	0.500	3.00	3	0.188	0.3750-24 UNJF-3B	AS5202-03S	AS5202-03SA	406709	406711
0.570	0.4565	0.083	0.888	0.445	0.392	2.00	0.500	3.12	3	0.250	0.4375-20 UNJF-3B	AS5202-04S	AS5202-04SA	406713	406715
0.633	0.5195	0.083	0.950	0.465	0.454	2.00	0.500	3.12	3	0.312	0.5000-20 UNJF-3B	AS5202-05S	AS5202-05SA	406717	406719
0.696	0.5825	0.091	1.012	0.495	0.511	2.00	0.500	3.25	3	0.375	0.5625-18 UNJF-3B	AS5202-06S	AS5202-06SA	406721	406723
0.758	0.6455	0.102	1.105	0.495	0.574	2.00	0.500	3.25	3	0.438	0.6250-18 UNJF-3B	AS5202-07S	AS5202-07SA	406725	406727
0.883	0.7715	0.102	1.240	0.560	0.692	2.12	0.750	3.57	3	0.500	0.7500-16 UNJF-3B	AS5202-08S	AS5202-08SA	406729	406731
0.946	0.8345	0.115	1.300	0.590	0.755	2.12	0.750	3.61	3	0.562	0.8125-16 UNJ-3B	AS5202-09S	AS5202-09SA	406733	406735
1.008	0.8985	0.115	1.415	0.610	0.809	2.12	0.750	3.66	3	0.625	0.8750-14 UNJF-3B	AS5202-10S	AS5202-10SA	406737	406739
1.164	1.0255	0.133	1.602	0.640	0.923	2.12	0.750	3.75	3	0.688	1.0000-12 UNJF-3B	AS5202-11S	AS5202-11SA	406741	406743
1.242	1.0885	0.133	1.665	0.640	0.983	2.12	0.750	3.75	3	0.750	1.0625-12 UNJ-3B	AS5202-12S	AS5202-12SA	406745	406747
1.370	1.2135	0.133	1.790	0.710	1.110	2.25	1.000	4.00	3	0.875	1.1875-12 UNJ-3B	AS5202-14S	AS5202-14SA	406749	406751
1.495	1.3385	0.133	1.965	0.710	1.233	2.25	1.000	4.05	3	1.000	1.3125-12 UNJ-3B	AS5202-16S	AS5202-16SA	406753	406755
1.808	1.6505	0.133	2.310	0.750	1.547	2.25	1.000	4.20	3	1.250	1.6250-12 UNJ-3B	AS5202-20S	AS5202-20SA	406757	406759
2.058	1.9005	0.133	2.628	0.750	1.797	2.25	1.000	4.20	3	1.500	1.8750-12 UNJ-3B	AS5202-24S	AS5202-24SA	406761	406763
2.433	2.2755	0.133	3.050	0.800	2.172	2.25	1.250	4.50	3	1.750	2.2500-12 UNJ-3B	AS5202-28S	AS5202-28SA	406765	406767
2.683	2.5265	0.133	3.520	0.800	2.422	2.50	1.250	4.60	3	2.000	2.5000-12 UNJ-3B	AS5202-32S	AS5202-32SA	406769	406771

Thread mills are available. See pages 8-18.

[Go to Port Tools Overview](#)

**Click to view the crossover chart
for MS33649 to AS5202**

AS5202 (MS33649) - PORT TOOL REAMER PILOT - CARBIDE TIPPED

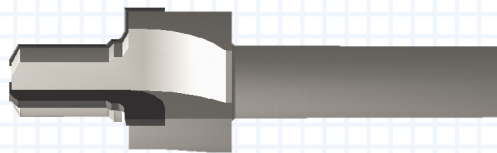
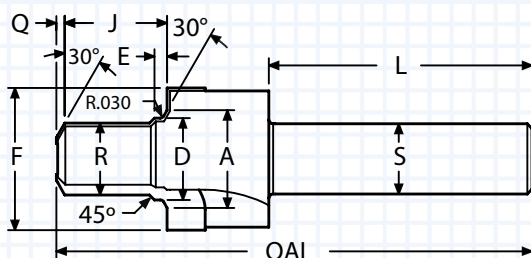

- Reams minor thread diameter to size
- Precision ground for maximum concentricity
- Meets the requirements of MS33649
- ALTiN+ coated tool for higher cutting speed
- This port requires a UNJ thread which specifies a larger minor-thread diameter

A	D	E	F	J	Q	R	L	S	OAL	FLUTES	TUBE	THREAD	ORDER #		EDP #	
													UNCOATED	ALTiN+	UNCOATED	ALTiN+
0.367	0.2665	0.071	0.575	0.425	0.025	0.219	2.00	0.500	3.00	3	N/A	0.2500-28 UNJF-3B	Solid Carbide			
													AS5202-01R	AS5202-01RA	406501	406503
0.446	0.3305	0.071	0.742	0.597	0.032	0.276	1.75	0.500	3.00	3	0.125	0.3125-24 UNJF-3B	Carbide Tipped			
													AS5202-02R	AS5202-02RA	406505	406511
0.508	0.3925	0.071	0.805	0.603	0.040	0.339	1.75	0.500	3.00	3	0.188	0.3750-24 UNJF-3B	AS5202-03R	AS5202-03RA	406513	406519
0.570	0.4565	0.083	0.888	0.676	0.040	0.393	1.88	0.500	3.12	3	0.250	0.4375-20 UNJF-3B	AS5202-04R	AS5202-04RA	406521	406527
0.633	0.5195	0.083	0.950	0.676	0.045	0.455	1.88	0.500	3.12	3	0.312	0.5000-20 UNJF-3B	AS5202-05R	AS5202-05RA	406529	406535
0.696	0.5825	0.091	1.012	0.729	0.060	0.513	1.88	0.500	3.38	3	0.375	0.5625-18 UNJF-3B	AS5202-06R	AS5202-06RA	406537	406543
0.758	0.6455	0.102	1.105	0.745	0.060	0.575	1.88	0.500	3.38	3	0.438	0.6250-18 UNJF-3B	AS5202-07R	AS5202-07RA	406545	406547
0.883	0.7715	0.102	1.240	0.854	0.070	0.693	2.12	0.750	3.84	3	0.500	0.7500-16 UNJF-3B	AS5202-08R	AS5202-08RA	406549	406555
0.946	0.8345	0.115	1.300	0.870	0.070	0.758	2.12	0.750	3.84	3	0.562	0.8125-16 UNJ-3B	AS5202-09R	AS5202-09RA	406557	406559
1.008	0.8985	0.115	1.415	0.950	0.080	0.810	2.12	0.750	3.94	3	0.625	0.8750-14 UNJF-3B	AS5202-10R	AS5202-10RA	406561	406567
1.164	1.0255	0.133	1.500	1.084	0.080	0.925	2.12	0.750	4.12	3	0.688	1.0000-12 UNJF-3B	AS5202-11R	AS5202-11RA	406569	406571
1.242	1.0885	0.133	1.665	1.084	0.080	0.985	2.12	0.750	4.12	3	0.750	1.0625-12 UNJ-3B	AS5202-12R	AS5202-12RA	406573	406579
1.370	1.2135	0.133	1.790	1.084	0.090	1.112	2.25	1.000	4.37	3	0.875	1.1875-12 UNJ-3B	AS5202-14R	AS5202-14RA	406581	406587
1.495	1.3385	0.133	1.965	1.084	0.090	1.235	2.25	1.000	4.37	3	1.000	1.3125-12 UNJ-3B	AS5202-16R	AS5202-16RA	406589	406595
1.683	1.5265	0.133	2.090	1.136	0.090	1.425	2.25	1.000	4.53	3	1.125	1.5000-12 UNJF-3B	AS5202-18R	AS5202-18RA	406597	406599
1.808	1.6505	0.133	2.310	1.136	0.090	1.549	2.25	1.000	4.54	3	1.250	1.6250-12 UNJ-3B	AS5202-20R	AS5202-20RA	406601	406603
2.058	1.9005	0.133	2.628	1.147	0.095	1.799	2.25	1.000	4.54	3	1.500	1.8750-12 UNJ-3B	AS5202-24R	AS5202-24RA	406605	406607
2.433	2.2755	0.133	3.050	1.263	0.095	2.174	2.50	1.250	4.92	3	1.750	2.2500-12 UNJ-3B	AS5202-28R	AS5202-28RA	406609	406611
2.683	2.5265	0.133	3.520	1.388	0.095	2.424	2.50	1.250	5.15	3	2.000	2.5000-12 UNJ-3B	AS5202-32R	AS5202-32RA	406613	406615

Thread mills are available. See pages 8-18.

[Go to Port Tools Overview](#)

**Click to view the crossover chart
for MS33649 to AS5202**

AS5202 (MS33649) - REAMER PILOT PORT TOOL COOLANT THROUGH - CARBIDE TIPPED

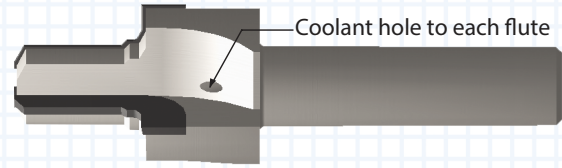
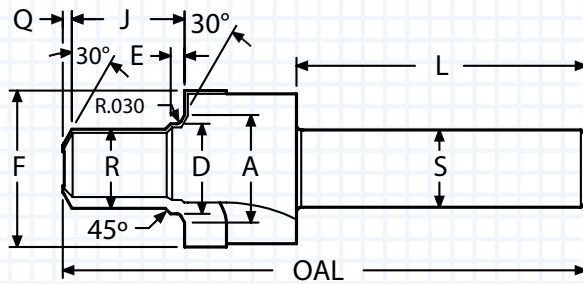

- Reams minor thread diameter to size
- Precision ground for maximum concentricity
- Meets the requirements of MS33649
- ALTiN+ coated tool for higher cutting speed
- This port requires a UNJ thread which specifies a larger minor thread diameter

A	D	E	F	J	Q	R	L	S	OAL	FLUTES	TUBE	THREAD	ORDER #		EDP #	
													UNCOATED	ALTiN+	UNCOATED	ALTiN+
0.446	0.3305	0.071	0.742	0.597	0.032	0.276	1.75	0.500	3.00	3	0.125	0.3125-24 UNJF-3B	AS5202-02R-X3	AS5202-02R-X3A	406507	406509
0.508	0.3925	0.071	0.805	0.603	0.040	0.339	1.75	0.500	3.00	3	0.188	0.3750-24 UNJF-3B	AS5202-03R-X3	AS5202-03R-X3A	406515	406517
0.570	0.4565	0.083	0.888	0.676	0.040	0.393	1.88	0.500	3.12	3	0.250	0.4375-20 UNJF-3B	AS5202-04R-X3	AS5202-04R-X3A	406523	406525
0.633	0.5195	0.083	0.950	0.676	0.045	0.455	1.88	0.500	3.12	3	0.312	0.5000-20 UNJF-3B	AS5202-05R-X3	AS5202-05R-X3A	406531	406533
0.696	0.5825	0.091	1.012	0.729	0.060	0.513	1.88	0.500	3.38	3	0.375	0.5625-18 UNJF-3B	AS5202-06R-X3	AS5202-06R-X3A	406539	406541
0.883	0.7715	0.102	1.240	0.854	0.070	0.693	2.12	0.750	3.84	3	0.500	0.7500-16 UNJF-3B	AS5202-08R-X3	AS5202-08R-X3A	406551	406553
1.008	0.8985	0.115	1.415	0.950	0.080	0.810	2.12	0.750	3.94	3	0.625	0.8750-14 UNJF-3B	AS5202-10R-X3	AS5202-10R-X3A	406563	406565
1.242	1.0885	0.133	1.665	1.084	0.080	0.985	2.12	0.750	4.12	3	0.750	1.0625-12 UNJ-3B	AS5202-12R-X3	AS5202-12R-X3A	406575	406577
1.370	1.2135	0.133	1.790	1.084	0.090	1.112	2.25	1.000	4.37	3	0.875	1.1875-12 UNJ-3B	AS5202-14R-X3	AS5202-14R-X3A	406583	406585
1.495	1.3385	0.133	1.965	1.084	0.090	1.235	2.25	1.000	4.37	3	1.000	1.3125-12 UNJ-3B	AS5202-16R-X3	AS5202-16R-X3A	406591	406593

Thread mills are available. See pages 8-18.

**Click to view the crossover chart
for MS33649 to AS5202**

[Go to Port Tools Overview](#)

MS16142 to SAE J1926 Port Tool Crossover Charts

Scientific Cutting Tools is in the process of changing the MS16142 and MS33649 port tools. **MS16142 tools will be phased out and replaced with SAE J1926 port tools. MS33649 tools will be replaced with AS5202 port tools.** Order numbers and EDP numbers have changed (please refer to chart below.) The cutting dimensions remain the same except for the number of flutes on larger sizes. Previously, the larger-sized tools had 4 or 5 flutes. **All SAE J1926 and AS5202 port tools now have 3 flutes.**

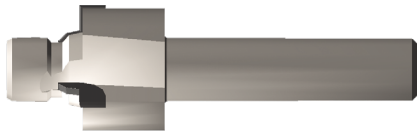

SOLID PILOT

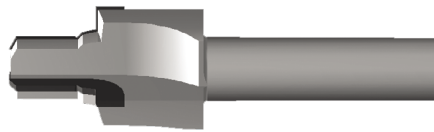

REAMER PILOT

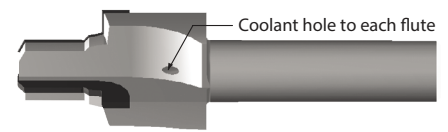

COOLANT THROUGH

SAE J1926-S Replaces MS16142-S			
MS16142-S		SAE J1926-S	
Old Part #	Old EDP	New Part #	New EDP
MS16142-2S	401119	SAEJ1926-02S	406301
MS16142-2SA	401219	SAEJ1926-02SA	406303
MS16142-3S	401125	SAEJ1926-03S	406305
MS16142-3SA	401225	SAEJ1926-03SA	406307
MS16142-4S	401128	SAEJ1926-04S	406309
MS16142-4SA	401228	SAEJ1926-04SA	406311
MS16142-5S	401131	SAEJ1926-05S	406313
MS16142-5SA	401231	SAEJ1926-05SA	406315
MS16142-6S	401134	SAEJ1926-06S	406317
MS16142-6SA	401234	SAEJ1926-06SA	406319
MS16142-8S	401137	SAEJ1926-08S	406321
MS16142-8SA	401237	SAEJ1926-08SA	406323
MS16142-10S	401101	SAEJ1926-10S	406325
MS16142-10SA	401201	SAEJ1926-10SA	406327
MS16142-12S	401104	SAEJ1926-12S	406329
MS16142-12SA	401204	SAEJ1926-12SA	406331
MS16142-14S	401107	SAEJ1926-14S	406333
MS16142-14SA	401207	SAEJ1926-14SA	406335
MS16142-16S	401110	SAEJ1926-16S	406337
MS16142-16SA	401210	SAEJ1926-16SA	406339
MS16142-20S	401113	SAEJ1926-20S	406341
MS16142-20SA	401213	SAEJ1926-20SA	406343
MS16142-24S	401116	SAEJ1926-24S	406345
MS16142-24SA	401216	SAEJ1926-24SA	406347
MS16142-32S	401122	SAEJ1926-32S	406349
MS16142-32SA	401222	SAEJ1926-32SA	406351

SAE J1926-R Replaces MS16142-R			
MS16142-R		SAE J1926-R	
Old Part #	Old EDP	New Part #	New EDP
MS16142-2R	401319	SAEJ1926-02R	406001
MS16142-2RA	401369	SAEJ1926-02RA	406003
MS16142-3R	401325	SAEJ1926-03R	406007
MS16142-3RA	401375	SAEJ1926-03RA	406009
MS16142-4R	401328	SAEJ1926-04R	406013
MS16142-4RA	401378	SAEJ1926-04RA	406015
MS16142-5R	401331	SAEJ1926-05R	406019
MS16142-5RA	401381	SAEJ1926-05RA	406021
MS16142-6R	401334	SAEJ1926-06R	406025
MS16142-6RA	401384	SAEJ1926-06RA	406027
MS16142-8R	401337	SAEJ1926-08R	406031
MS16142-8RA	401387	SAEJ1926-08RA	406033
MS16142-10R	401301	SAEJ1926-10R	406037
MS16142-10RA	401351	SAEJ1926-10RA	406039
MS16142-12R	401304	SAEJ1926-12R	406043
MS16142-12RA	401354	SAEJ1926-12RA	406045
MS16142-14R	401307	SAEJ1926-14R	406049
MS16142-14RA	401357	SAEJ1926-14RA	406051
MS16142-16R	401310	SAEJ1926-16R	406055
MS16142-16RA	401360	SAEJ1926-16RA	406057
MS16142-20R	401313	SAEJ1926-20R	406061
MS16142-20RA	401363	SAEJ1926-20RA	406063
MS16142-24R	401316	SAEJ1926-24R	406067
MS16142-24RA	401366	SAEJ1926-24RA	406069
MS16142-32R	401322	SAEJ1926-32R	406073
MS16142-32RA	401372	SAEJ1926-32RA	406075

SAE J1926-X Replaces MS16142-X			
MS16142-X		SAE J1926-X	
Old Part #	Old EDP	New Part #	New EDP
MS16142-2R-X3	401513	SAEJ1926-02R-X3	406201
MS16142-2R-X3A	401563	SAEJ1926-02R-X3A	406203
MS16142-3R-X3	401516	SAEJ1926-03R-X3	406205
MS16142-3R-X3A	401566	SAEJ1926-03R-X3A	406207
MS16142-4R-X3	401519	SAEJ1926-04R-X3	406209
MS16142-4R-X3A	401569	SAEJ1926-04R-X3A	406211
MS16142-5R-X3	401522	SAEJ1926-05R-X3	406213
MS16142-5R-X3A	401572	SAEJ1926-05R-X3A	406215
MS16142-6R-X3	401525	SAEJ1926-06R-X3	406217
MS16142-6R-X3A	401575	SAEJ1926-06R-X3A	406219
MS16142-8R-X5	401528	SAEJ1926-08R-X3	406221
MS16142-8R-X5A	401578	SAEJ1926-08R-X3A	406223
MS16142-10R-X5	401501	SAEJ1926-10R-X3	406225
MS16142-10R-X5A	401551	SAEJ1926-10R-X3A	406227
MS16142-12R-X5	401504	SAEJ1926-12R-X3	406229
MS16142-12R-X5A	401554	SAEJ1926-12R-X3A	406231
MS16142-14R-X5	401507	SAEJ1926-14R-X3	406233
MS16142-14R-X5A	401557	SAEJ1926-14R-X3A	406235
MS16142-16R-X5	401510	SAEJ1926-16R-X3	406237
MS16142-16R-X5A	401560	SAEJ1926-16R-X3A	406239

[Go to Port Tools Overview](#)

The SAE J1926 port tools will replace MS16142 port tools.

The new 3 fluted design is less likely to chatter, requires less horsepower, and has a larger flute pocket for improved chip evacuation.

MS33649 to AS5202 Port Tool Crossover Charts

Scientific Cutting Tools is in the process of changing the MS33649 and MS16142 port tools. **MS33649 tools will be phased out and replaced with AS5202 port tools. MS16142 tools will be replaced with SAE J1926 port tools.** Order numbers and EDP numbers have changed (please refer to chart below.) The cutting dimensions remain the same except for the number of flutes on larger sizes. Previously, the larger-sized tools had 4 or 5 flutes. **All SAE J1926 and AS5202 port tools now have 3 flutes.**

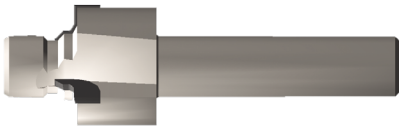

SOLID PILOT



REAMER PILOT

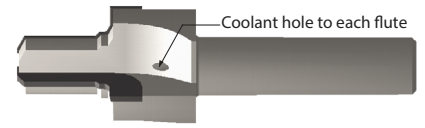

COOLANT THROUGH

AS5202-S Replaces MS33649-S			
MS33649-S		AS5202-S	
Old Part #	Old EDP	New Part #	New EDP
MS33649-1S	401616	AS5202-01S	406701
MS33649-1SA	401686	AS5202-01SA	406703
MS33649-2S	401628	AS5202-02S	406705
MS33649-2SA	401698	AS5202-02SA	406707
MS33649-3S	401634	AS5202-03S	406709
MS33649-3SA	401704	AS5202-03SA	406711
MS33649-4S	401637	AS5202-04S	406713
MS33649-4SA	401707	AS5202-04SA	406715
MS33649-5S	401640	AS5202-05S	406717
MS33649-5SA	401710	AS5202-05SA	406719
MS33649-6S	401643	AS5202-06S	406721
MS33649-6SA	401713	AS5202-06SA	406723
MS33649-7S	401646	AS5202-07S	406725
MS33649-7SA	401716	AS5202-07SA	406727
MS33649-8S	401649	AS5202-08S	406729
MS33649-8SA	401719	AS5202-08SA	406731
MS33649-9S	401652	AS5202-09S	406733
MS33649-9SA	401722	AS5202-09SA	406735
MS33649-10S	401601	AS5202-10S	406737
MS33649-10SA	401671	AS5202-10SA	406739
MS33649-11S	401604	AS5202-11S	406741
MS33649-11SA	401674	AS5202-11SA	406743
MS33649-12S	401607	AS5202-12S	406745
MS33649-12SA	401677	AS5202-12SA	406747
MS33649-14S	401610	AS5202-14S	406749
MS33649-14SA	401680	AS5202-14SA	406751
MS33649-16S	401613	AS5202-16S	406753
MS33649-16SA	401683	AS5202-16SA	406755
MS33649-20S	401619	AS5202-20S	406757
MS33649-20SA	401689	AS5202-20SA	406759
MS33649-24S	401622	AS5202-24S	406761
MS33649-24SA	401692	AS5202-24SA	406763
MS33649-28S	401625	AS5202-28S	406765
MS33649-28SA	401695	AS5202-28SA	406767
MS33649-32S	401631	AS5202-32S	406769
MS33649-32SA	401701	AS5202-32SA	406771

AS5202-R Replaces MS33649-R			
MS33649-R		AS5202-R	
Old Part #	Old EDP	New Part #	New EDP
MS33649-1R	401778	AS5202-01R	406501
MS33649-1RA	401878	AS5202-01RA	406503
MS33649-2R	401793	AS5202-02R	406505
MS33649-2RA	401893	AS5202-02RA	406511
MS33649-3R	401802	AS5202-03R	406513
MS33649-3RA	401902	AS5202-03RA	406519
MS33649-4R	401808	AS5202-04R	406521
MS33649-4RA	401908	AS5202-04RA	406527
MS33649-5R	401814	AS5202-05R	406529
MS33649-5RA	401914	AS5202-05RA	406535
MS33649-6R	401820	AS5202-06R	406537
MS33649-6RA	401920	AS5202-06RA	406543
MS33649-7R	401826	AS5202-07R	406545
MS33649-7RA	401926	AS5202-07RA	406547
MS33649-8R	401829	AS5202-08R	406549
MS33649-8RA	401929	AS5202-08RA	406555
MS33649-9R	401835	AS5202-09R	406557
MS33649-9RA	401935	AS5202-09RA	406559
MS33649-10R	401751	AS5202-10R	406561
MS33649-10RA	401851	AS5202-10RA	406567
MS33649-11R	401757	AS5202-11R	406569
MS33649-11RA	401857	AS5202-11RA	406571
MS33649-12R	401760	AS5202-12R	406573
MS33649-12RA	401860	AS5202-12RA	406579
MS33649-14R	401766	AS5202-14R	406581
MS33649-14RA	401866	AS5202-14RA	406587
MS33649-16R	401769	AS5202-16R	406589
MS33649-16RA	401869	AS5202-16RA	406595
MS33649-18R	401775	AS5202-18R	406597
MS33649-18RA	401875	AS5202-18RA	406599
MS33649-20R	401781	AS5202-20R	406601
MS33649-20RA	401881	AS5202-20RA	406603
MS33649-24R	401787	AS5202-24R	406605
MS33649-24RA	401887	AS5202-24RA	406607
MS33649-28R	401790	AS5202-28R	406609
MS33649-28RA	401890	AS5202-28RA	406611
MS33649-32R	401799	AS5202-32R	406613
MS33649-32RA	401899	AS5202-32RA	406615

AS5202-X Replaces MS33649-X			
MS33649-X		AS5202-X	
Old Part #	Old EDP	New Part #	New EDP
MS33649-2R-X3	401963	AS5202-02R-X3	406507
MS33649-2R-X3A	402013	AS5202-02R-X3A	406509
MS33649-3R-X3	401966	AS5202-03R-X3	406515
MS33649-3R-X3A	402016	AS5202-03R-X3A	406517
MS33649-4R-X3	401969	AS5202-04R-X3	406523
MS33649-4R-X3A	402019	AS5202-04R-X3A	406525
MS33649-5R-X3	401972	AS5202-05R-X3	406531
MS33649-5R-X3A	402022	AS5202-05R-X3A	406533
MS33649-6R-X3	401975	AS5202-06R-X3	406539
MS33649-6R-X3A	402025	AS5202-06R-X3A	406541
MS33649-8R-X5	401978	AS5202-08R-X3	406551
MS33649-8R-X5A	402028	AS5202-08R-X3A	406553
MS33649-10R-X5	401951	AS5202-10R-X3	406563
MS33649-10R-X5A	402001	AS5202-10R-X3A	406565
MS33649-12R-X5	401954	AS5202-12R-X3	406575
MS33649-12R-X5A	402004	AS5202-12R-X3A	406577
MS33649-14R-X5	401957	AS5202-14R-X3	406583
MS33649-14R-X5A	402007	AS5202-14R-X3A	406585
MS33649-16R-X5	401960	AS5202-16R-X3	406591
MS33649-16R-X5A	402010	AS5202-16R-X3A	406593

The AS5202 port tools will replace MS33649 port tools.

The new 3 fluted design is less likely to chatter, requires less horsepower, and has a larger flute pocket for improved chip evacuation.

[Go to Port Tools Overview](#)

